

IN • VANVM • LABORAVERT • QUI • AEDIFICANT • EAM

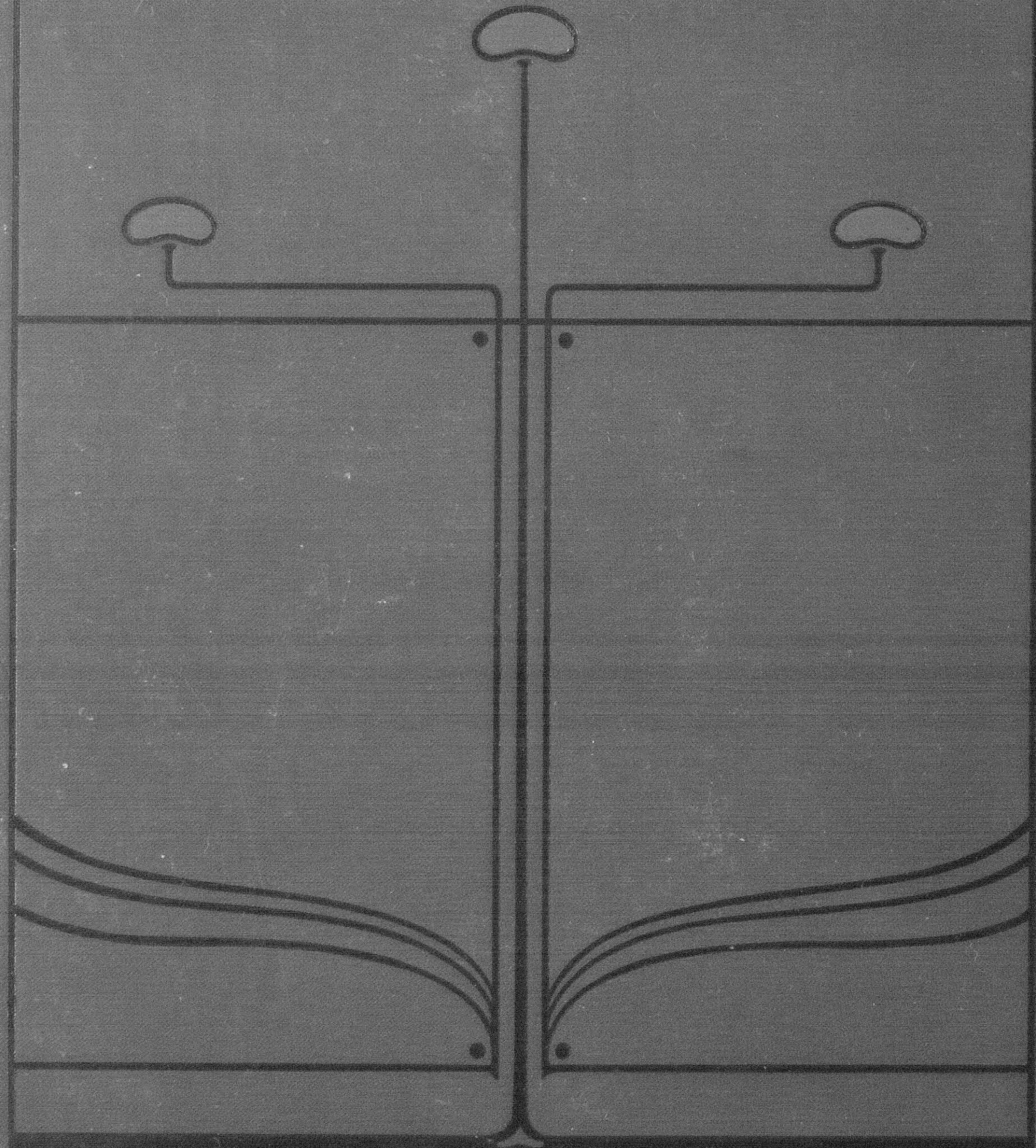

MODERN  
HOUSE  
CONSTRUCTION

DIV: 4

REF 728 LIS

BLACKIE AND  
SON LIMITED

NI SI • DOMINVS • AEDIFICAVERIT • DOMVM

MODERN HOUSE  
CONSTRUCTION

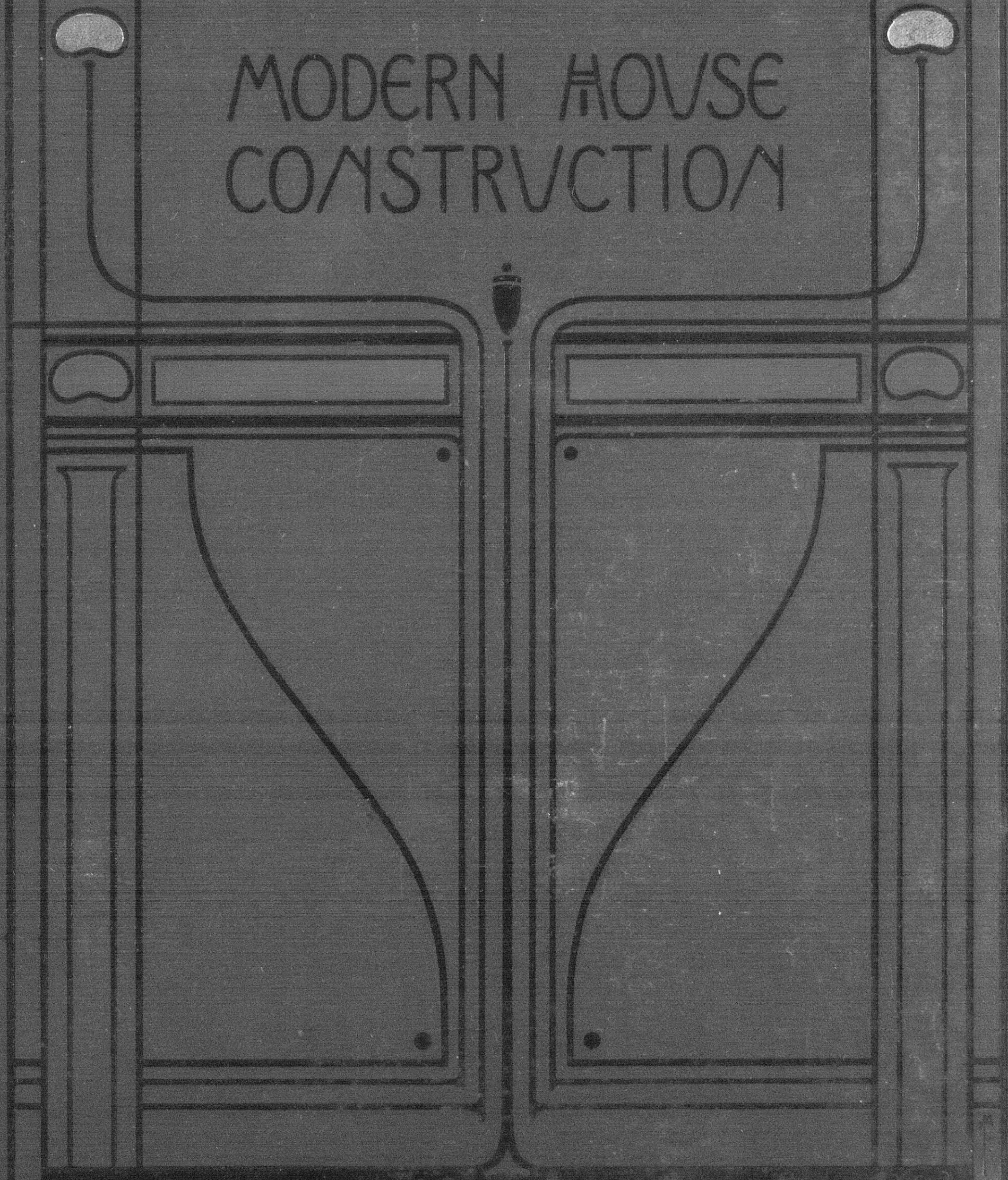



LISTER-SUTCUFFE, G (ed)

THE PRINCIPLES & PRACTICE OF MODERN HOUSE  
CONSTRUCTION - DIV VOL 4

00215164



HISTORIC SCOTLAND TCRE

DATE 13/11/07 PRICE:

BIB: 225113

SHELFMARK REF 728 LIS



13.

WPD  
6 vols  
£125.00



THE PRINCIPLES AND PRACTICE  
OF  
MODERN HOUSE-CONSTRUCTION





THE PRINCIPLES AND PRACTICE  
OF  
MODERN HOUSE-CONSTRUCTION

INCLUDING

WATER-SUPPLY AND FITTINGS—SANITARY FITTINGS AND  
PLUMBING—DRAINAGE AND SEWAGE-DISPOSAL—WARMING  
VENTILATION—LIGHTING—SANITARY ASPECTS OF FUR-  
NITURE AND DECORATION—CLIMATE AND SITUATION  
STABLES—SANITARY LAW, &c.

WRITTEN BY

F. W. ANDREWES, M.D., F.R.C.P., D.P.H.	PROF. ROBERT KERR, F.R.I.B.A.
A. WYNTER BLYTH, M.R.C.S., F.I.C.	HENRY LAW, M.Inst.C.E., F.San.I.
H. PERCY BOULNOIS, M.Inst.C.E., F.San.I.	F. W. LOCKWOOD, F.I.S.E.
E. A. CLAREMONT, M.I.E.E., M.I.M.E.	J. MURRAY SOMERVILLE
HENRY CLAY, R.I.Pl.	W. SPINKS, A.M.Inst.C.E., Pr.I.S.E.
E. R. DOLBY, A.M.Inst.C.E., M.I.M.E.	G. LISTER SUTCLIFFE, A.R.I.B.A., M.San.I.
WILLIAM HENMAN, F.R.I.B.A.	WILLIAM H. WELLS
H. JOSSÉ JOHNSON, M.B., D.P.H.	E. F. WILLOUGHBY, M.D., D.P.H.
	KEITH D. YOUNG, F.R.I.B.A.

EDITED BY

G. LISTER SUTCLIFFE

ARCHITECT

ASSOCIATE OF THE ROYAL INSTITUTE OF BRITISH ARCHITECTS, MEMBER OF THE SANITARY INSTITUTE  
AUTHOR OF "CONCRETE: ITS NATURE AND USES", ETC.

*ILLUSTRATED BY ABOVE 700 FIGURES IN THE TEXT, AND A SERIES OF SEPARATELY-PRINTED PLATES*

DIVISIONAL-VOL. IV.

BLACKIE & SON, LIMITED  
LONDON, GLASGOW, EDINBURGH, AND DUBLIN

1899



	Page
"Aerated bacterial self-acting filter"—Analysis of filtrate—Construction of Ducat's filter—Dibdin's process of filtration—Analysis of sewage and filtrates, Ducat's filter—Stages in the purification of sewage—Prof. Dibdin's experiments - - - - -	32
CHAP. VIII.—INTERCEPTION OR DRY SYSTEMS. Rivers Pollution Commission on interception-systems—Midden-closets—The Nottingham midden-privy—The Burnley midden-closet—The Stamford midden-closet—The bevel-midden—Pail-closets—Rochdale and Birmingham pails—Pail-closets with cinder-sifters—The Goux pail—Rochdale night-soil vans—Treatment of night-soil—Treatment at Manchester—Analysis of resultant manure—Committees of L. G. Board and Society of Arts on interception-systems - - - - -	44
CHAP. IX.—SEWAGE-DISPOSAL FROM HOUSES NOT CONNECTED WITH ANY SEWERAGE-SYSTEM. General considerations—Cesspools—Their position, size, shape, and construction—Connection of drains—Overflows—Cleansing—Merryweather's pneumatic cesspool-emptier—Cosham's sewage-precipitation tanks—Septic tank and filters—Moule's earth-closet—Dr. Poore on earth-closets—British Sanitary Co.'s self-acting earth-closet - - - - -	56
 SECTION X.—WARMING.  	
By E. R. DOLBY, A.M.Inst.C.E., M.I.M.E.	
CHAP. I.—INTRODUCTORY. Warming and ventilation—Temperature desired—Houses in the United Kingdom—Systems of warming—Chief requirements—Experimental data - - - - -	67
CHAP. II.—OPEN FIRES AND STOVES. Earliest open fires—Currents of air produced and products of combustion—Objections to open fires—Fire-grates with special air-ducts—Advantages of open fires—General principles of design—The Nautilus grate—The Galton grate and stove—The Grundy grate—Purification of incoming air—The Teale grate—Teale's and Rumford's experiments—The Teale front-hob grate—The Rational grate—Boyd's grates—Heim's "Helios" smoke-consuming grates and stoves—The "Hestia" stove—To burn coal without smoke—Controlled-combustion heating-apparatus—The Shorland grate—Shorland's Calorigen—The smoke- nuisance—Dulier's smoke-absorbing apparatus—Kitchen-ranges—Petter's refuse-destroyer for kitchen-ranges - - - - -	69
CHAP. III.—GAS-STOVES AND OIL-STOVES. 1. GAS-STOVES. Grates filled with asbestos balls—Necessity for flues—Stoves with iron fret fronts—Stoves with hot-air passages—Tubular gas-stoves—Products of combustion—Condensing stoves—Clark's "Hygienic" condensing gas-stove—Flat stoves - - - - -	88
2. OIL-STOVES. The "Emperor"—Products of combustion—Condensing stoves	92
CHAP. IV.—HEATING BY HOT OR WARMED AIR. Advantages and disadvantages—Principal points requiring attention—Air-filtering apparatus—Fans—Temperature of air in rooms—Air-currents in rooms—The Smead system of heating by hot air—The Smead furnace—Air inlets and outlets, Smead system—Regulators—The Heim system—The Calorifer—Key's plenum system of warming and ventilation—Apparatus for filtering and washing air—Humidity of air for warming—Position of	

	Page
inlets and outlets—Warmed air in conjunction with open fires—Drs. Drysdale and Hayward's arrangements—Air inlets and outlets—Methods of air-extraction—Purification of incoming air - - - - -	93
CHAP. V.—HEATING BY HOT WATER. Comparison of low-pressure and high-pressure systems—Hot-water apparatus compared with open grates and stoves—Position of radiators—Objections to hot-water apparatus—Combined system of open fires and hot-water apparatus - - - - -	108
1. THE LOW-PRESSURE SYSTEM. Boilers—Incrustation—Brick settings for boilers—Gas-heated boilers—Independent conical boiler—The "Marlor" boiler—The "Excelsior"—Plain saddle boiler—Independent saddle boilers—The "Devona" boiler—The "Edina"—Cast-iron boilers—The "Oxford"—The "Defiance"—The "Viaduct"—The "Challenge"—The Renton Gibbs tubular boiler—Körting's boiler—Körting's automatic draught-regulator—Radiating surfaces—Pipes, jointing and fixing—Expansion-joints—Pipe-trenches—Channels behind skirtings—Radiators with horizontal tubes—Radiators with vertical loops—Coil-radiators—Air-inlet radiators—Stop-valves—Safety-valves—Simple arrangements of low-pressure apparatus—Important points—Larger installations—Two modes of connecting radiators with pipes—Arrangement of pipes with separate circuit to each floor—Circular radiators—Other arrangements of pipes—The "Mills" system of piping—Apparatus for suburban house - - - - -	110
2. THE HIGH-PRESSURE SYSTEM. Temperature of water—Pipes and jointing—General arrangement—Advantages and disadvantages - - - - -	138
CHAP. VI.—LOW-PRESSURE STEAM HEATING. General description—Steam—Comparison of heating by steam and hot water—Principal points—Boilers—Cornish boilers—The "Majestic" independent boiler—The "Caloric" boiler—The "Pioneer"—Boiler-fittings—Körting's system of low-pressure steam heating—Method of working the apparatus—Steam-valves—Automatic draught-regulator—Advantages of the system—Radiators—Principal requirements of steam heating-apparatus—Pipes—Stop-valves - - - - -	140
CHAP. VII.—GENERAL CONCLUSIONS. Open fires—Open fires with some auxiliary system—Close stoves and fireplaces—Gas-fires—Conclusion - - - - -	152

## SECTION XI.—WARMING AND COOKING BY ELECTRICITY.

By E. A. CLAREMONT, M.I.E.E., M.I.M.E.

Coal-fires—Requirements of good cooking-apparatus—Theory of electric heating—Resistance-wires—Their insulation and arrangement—Electric kitchens—Ovens—Cost of cooking by electricity—Pressure—Electric kettles—Fry-pans—Flat-irons—Efficiency of appliances—Radiators—Advantages of warming by electricity - - - - -	157
---	-----



LISTER-SUTCLIFFE, G (ED)

REF 728 LIS

THE PRINCIPLES & PRACTICE OF MODERN HOUSE  
CONSTRUCTION - DIVISIONAL VOL I

00215161



HISTORIC SCOTLAND TCRC

DATE 13/11/07 PRICE:

BIB: 225108

SHELFMARK REF 728 LIS



# ILLUSTRATIONS.

## DIVISIONAL-VOL. IV.

Plate		Page
XV.	THE SEPTIC TANK SYSTEM OF SEWAGE TREATMENT - - - - -	32
„	XVI. COL. DUCAT'S AÉRATED BACTERIAL SEWAGE-FILTER - - - - -	41
„	XVII. GRUNDY'S WARM-AIR VENTILATING FIRE-GRATE - - - - -	74
„	XVIII. PLANS OF A PAIR OF SUBURBAN HOUSES, SHOWING HOT-WATER PIPES - - - - -	136
„	XIX. SECTION THROUGH SUBURBAN HOUSE, SHOWING HEATING ARRANGEMENTS - - - - -	137

## LIST OF ILLUSTRATIONS IN TEXT.

Fig.		Page	Fig.		Page
424.	Borough of Portsmouth: Sewage-outfall Works - - - - -	7	446.	British Sanitary Co.'s Self-acting Earth-closet - - - - -	63
425.	Manlove and Alliot's Filter-press for Sewage Sludge - - - - -	20	<i>SECTION X.</i>		
426.	Sewage-filter of Sand, Gravel, and Magnetone - - - - -	24	447.	Currents of Air produced by an Open Fire Out-of-doors - - - - -	70
427.	Polarite Sewage-filter - - - - -	25	448.	Currents of Air produced by an Open Fire in a Room - - - - -	70
428.	Lowcock's Sewage-filter - - - - -	26	449.	Elevation of Fire-grate, with special Air-duct - - - - -	71
429.	Sewage-filter of Coke and Sand - - - - -	28	450.	Plan of Fire-grate, with special Air-duct - - - - -	71
430.	Insanitary Privy and Cesspool - - - - -	46	451.	Front View of Nautilus Grate - - - - -	72
431.	Midden-closet in use at Nottingham - - - - -	47	452.	Section of Nautilus Grate - - - - -	72
432.	„ „ Burnley - - - - -	48	453.	Plan of Galton Grate - - - - -	72
433.	„ „ Stamford - - - - -	48	454.	Chimney-breast, showing Warm-air Flue, &c., from Galton Grate - - - - -	72
434.	„ formerly used in Manchester - - - - -	49	455.	Section of Room, showing Air-flues for Galton Grate - - - - -	73
435.	Rochdale Excrement-pail and Cover - - - - -	50	456.	Section of Galton Grate - - - - -	73
436.	Birmingham „ „ - - - - -	50	457.	Plan of the Galton Independent Stove - - - - -	73
437.	View of Manchester Privy with Cinder-sifter - - - - -	51	458.	Section „ „ „ - - - - -	74
438.	“Goux” Excrement-pail and Mould - - - - -	51	459.	Front View of Teale Fire-grate - - - - -	75
439.	Rochdale Night-soil Van - - - - -	52	460.	Vertical Section of Teale Fire-grate - - - - -	75
440.	Plan of Country-house and Grounds - - - - -	57	461.	Plan of Teale Fire-grate - - - - -	75
441.	Section of Circular Cesspool - - - - -	59	462.	Front View of Teale Fireplace - - - - -	77
442.	Section of Double Cesspool - - - - -	59	463.	„ „ Front-hob Grate - - - - -	77
443.	Merryweather's Pneumatic Cesspool-emptier - - - - -	60	464.	„ „ Boyd's Register-gate - - - - -	78
444.	Cosham's Sewage-precipitation Tank, with Screening and Chemical Chamber - - - - -	61	465.	Vertical Section of Boyd's Register-grate - - - - -	78
445.	View of Moule's Earth-closet - - - - -	62			



Fig.	Page	Fig.	Page
466.—Boyd's Grate-body and Grating of Fire-brick - - - - -	79	510.—The "Oxford" Cast-iron Boiler - - -	115
467.—Boyd's Warm-air Grate - - - - -	79	511.—Two Rings of the "Oxford" Boiler - -	116
468.—"Helios" Smoke-consuming Stove - - -	80	512.—Fire-pot of the "Oxford" Boiler - -	116
469.—Front of "Helios" Smoke-consuming Stove - - - - -	81	513.—The "Defiance" Cast-iron Boiler - -	117
470.—The "Hestia" Stove - - - - -	82	514.—The "Viaduct" Cast-iron Boiler - -	118
471.—Plan of Controlled-combustion Heating Apparatus - - - - -	83	515.—The "Challenge" Cast-iron Boiler - -	119
472.—Section of Controlled-combustion Heating Apparatus - - - - -	84	516.—The "Renton Gibbs" Tubular Boiler -	120
473.—Front of Controlled-combustion Heating Apparatus - - - - -	84	517.—View of Exterior of Körting's Boiler -	120
474.—Section of Shorland's Grate and Plan of Flues - - - - -	85	518.—Section of Körting's Boiler - - - - -	121
475.—Front View of Shorland's Fireplace - -	85	519.—Körting's Automatic Draught-regulator -	122
476.—Shorland's Calorigen - - - - -	86	520.—Plan of Hot-water Pipes - - - - -	122
476A.—Petter's Refuse-destroyer - - - - -	88	521.—Richardson's India-rubber Expansion-joint - - - - -	123
477.—Burner for Asbestos-lump Fire - - - -	89	522.—Roller Stool for Pipes - - - - -	123
478.—Gas-stove with Iron Fret Front - - - -	89	523.—Roller Bracket for Pipes - - - - -	123
479.—Gas-stove with Flues for Utilizing Waste Heat - - - - -	90	524.—Bracket and Sling for Pipes - - - -	123
480.—Tubular Gas-stove - - - - -	90	525.—T-iron Bracket for Pipes - - - - -	123
481.—"Syphon" Condensing Gas-stove - - - -	91	526.—Diagrammatic View of Low-pressure Hot-water Pipes - - - - -	124
482.—Flat Gas-stove for fixing under Floors -	92	527.—Pipes in Channel formed in Wall - - -	124
483.—The "Emperor" Oil-stove - - - - -	92	528.—The "Safford" Radiator - - - - -	125
484-488.—Five Arrangements for Entrance and Exit of Warmed Air - - - - -	95	529.—Coil Radiator, with Wire Guard - - -	125
489.—The "Smead" Furnace - - - - -	96	530.—Coil Radiator in Case, with Air-inlet, &c. - - - - -	126
490.—View of "Smead" Furnace set in Brick-work - - - - -	97	531.—Rosser and Russell's Ventilating Radiator - - - - -	127
491.—General Arrangement of Inlets and Outlets, "Smead" System - - - - -	98	532.—Section of Full-way "Peet" Valve - - -	128
492.—Plan showing Stack of Inlets and Outlets, "Smead" System - - - - -	98	533.—Radiator with Elbow Stop-valve - - -	128
493.—Register and Regulator - - - - -	99	534.—Simplest System of Low-pressure Heating - - - - -	129
494.—Section of Duct, showing Valve - - - -	99	535.—Simple Low-pressure Hot-water Apparatus, with Air-pipe - - - - -	129
495.—Vertical Section of Calorifer from Back to Front - - - - -	100	536.—View of Low-pressure Hot-water Apparatus for Heating Two Floors with One Circuit - - - - -	130
496.—Vertical Section of Calorifer from Side to Side - - - - -	100	537.—Method of Connecting Radiators to one Circulation-pipe only - - - - -	132
497.—Plan of Calorifer - - - - -	100	538.—Method of Connecting Radiators to Flow and Return Pipes - - - - -	132
498.—Vertical Section through Radiator of Calorifer - - - - -	101	539.—Radiators on Branch Circulation-pipe -	132
499.—Section through Floor of Corridor, showing Passage of Heated Air - - - - -	106	540.—Low-pressure Hot-water Apparatus, with Separate Circuit for each floor - - - - -	133
500.—Air-inlet from Corridor to Room - - -	106	541.—Circular Radiator for Hall - - - - -	133
501.—Air-outlet from Room - - - - -	106	542.—Two Arrangements of Vertical Flow and Return Pipes for Radiators - - - - -	134
502.—Cross-tube Gas Boiler - - - - -	111	543.—View of the "Mills" System of Piping - - - - -	135
503.—Independent Conical Boiler - - - - -	111	544.—Method of Joining Pipes for High-pressure Heating - - - - -	138
504.—The "Marlor" Boiler - - - - -	112	545.—View of High-pressure Hot-water Apparatus - - - - -	138
505.—The "Excelsior" Boiler - - - - -	112	546.—The "Trentham" Cornish Boiler - - -	142
506.—Simple Saddle Boiler - - - - -	113	547.—The "Majestic" Independent Boiler for Steam-heating - - - - -	142
507.—Independent Saddle Boiler - - - - -	114	548.—The "Caloric" Boiler for Steam-heating - - - - -	143
508.—The "Devona" Saddle Boiler - - - - -	114		
509.—The "Edina" Boiler - - - - -	114		

Fig.	Page	Fig.	Page
549.—Section and Plan of the "Pioneer" Boiler - - - - -	144	<i>SECTION XI.</i>	
550.—View of the "Pioneer" Boiler - - - -	145	555.—An Electric Kitchen - - - - -	160
551.—General Arrangements of Körting's Low-pressure Steam Apparatus - - - - -	146	556.—" " Oven - - - - -	161
552.—View of Steam-valve - - - - -	147	557.—" " Kettle - - - - -	162
553.—Körting's Radiators - - - - -	150	558.—" " Fry-pan - - - - -	162
554.—Dewrance's Renewable Valve - - - -	151	559.—" " Flat-iron - - - - -	162
		560.—Electric Radiators - - - - -	163



SECTION IX.  
SEWAGE-DISPOSAL

BY

H. PERCY BOULNOIS

M. INST. C. E., F. SAN. INST., ETC.

LATE CITY ENGINEER OF LIVERPOOL, PAST PRESIDENT OF THE INCORPORATED ASSOCIATION OF MUNICIPAL AND SANITARY ENGINEERS  
PAST PRESIDENT OF THE NORTHERN BRANCH OF THE SANITARY INSPECTORS' ASSOCIATION  
PAST PRESIDENT OF THE LIVERPOOL ENGINEERING SOCIETY  
AUTHOR OF "THE MUNICIPAL AND SANITARY ENGINEER'S HANDBOOK", "PRACTICAL HINTS ON TAKING A HOUSE", ETC.





## SECTION IX.—SEWAGE-DISPOSAL.

---

### CHAPTER I.

#### SEWAGE.

**An important consideration**, so far as a sanitary house is concerned, is the getting rid of the waste products known as "sewage", in a manner that shall be expeditious, inoffensive, and economical. The question of sanitary appliances, drains, and traps has been dealt with by other contributors, but the question of the ultimate disposal of the sewage must now be considered.

#### ERRATUM.

---

In Div.-Vol. II., page 221, line 6,  
for "each gallon" read "1000 gallons".

In the United Kingdom, the  
and conduits or drains direct  
y dealt with in a variety of  
disposal of the sewage from  
n, which in its turn will also  
question of the disposal of  
position and quantity.

products from communities,  
ie supply, and the admittance  
the habits of the community.

The measure of the dry-weather flow may be readily estimated, when the supply of water per head of the population is ascertained, but allowance must be made for subsoil water in those cases where it is admitted, either purposely or accidentally, into the drains and sewers. In addition to which must be added the "manufacturers' waste", which in some special cases is necessarily considerable. The storm-water flow, which is dependent upon the rainfall, is, on the other hand, somewhat difficult to estimate, without a series of observations extending over a considerable period of time, and made with a view to estimate the amount of the rainfall upon the area drained by the sewers; and provision must be made for dealing in some manner with the *maximum* quantity of water which is likely to reach these sewers.



## SECTION IX.—SEWAGE-DISPOSAL.

---

### CHAPTER I.

#### SEWAGE.

**An important consideration**, so far as a sanitary house is concerned, is the getting rid of the waste products known as "sewage", in a manner that shall be expeditious, inoffensive, and economical. The question of sanitary appliances, drains, and traps has been dealt with by other contributors, but the question of the ultimate disposal of the sewage must now be considered.

In nearly every town or large community in the United Kingdom, the sewage from the houses now passes by underground conduits or drains direct into the arterial system of sewers, to be ultimately dealt with in a variety of ways which will be presently described. The disposal of the sewage from isolated or country houses is a more difficult problem, which in its turn will also be discussed. Before proceeding to deal with the question of the disposal of sewage from towns, it will be well to consider its composition and quantity.

**Sewage** may be described as the various waste products from communities, mixed with a quantity of water which varies with the supply, and the admittance or otherwise of the subsoil and rain water, and also the habits of the community. The measure of the dry-weather flow may be readily estimated, when the supply of water per head of the population is ascertained, but allowance must be made for subsoil water in those cases where it is admitted, either purposely or accidentally, into the drains and sewers. In addition to which must be added the "manufacturers' waste", which in some special cases is necessarily considerable. The storm-water flow, which is dependent upon the rainfall, is, on the other hand, somewhat difficult to estimate, without a series of observations extending over a considerable period of time, and made with a view to estimate the amount of the rainfall upon the area drained by the sewers; and provision must be made for dealing in some manner with the *maximum* quantity of water which is likely to reach these sewers.



With regard to the chemical composition and degree of dilution of any sewage, this must also necessarily vary in every district, but the late well-known chemist, Dr. C. Meymott Tidy, made the following determination of the **excrementitious matter in sewage**:—

“Every adult male person voids on an average 60 ozs. (= 3 pints) of urine daily. The 60 ozs. contains an average of 2·53 ozs. of dry solid matter, consisting of—

Urea, ... ..	512·4 grains.
Extractives (pigment, mucus, uric acid), ... ..	169·5 „
Salts (chiefly chlorides of sodium and potassium), ... ..	425·0 „
	1106·9 = 2·53 ozs.

“Every adult male person voids about 1750 grains (or 4 ozs.) of fæces daily, of which 75 per cent is moisture. The dry fæcal matter passed daily is therefore about 1 oz. per adult head of the population. Of this dry fæcal matter, about 88 per cent is organic matter (of which 6 parts are nitrogen), and 12 per cent inorganic (of which 4 parts are phosphoric acid); of this dry fæcal matter, 11 per cent is soluble in water.”

Other experimentalists give about 36 ozs. of urine and 1½ ozs. of fæcal matter for each person in 24 hours, and Messrs. Wolff & Lehmann, from investigations made with a mixed population of 100,000 persons for a year, give the following result:—3 ozs. of fæcal matter and 26 ozs. of urine per day. It will thus be seen that there is some divergence of opinion as to the average amount of these matters voided daily by an adult, and it is really more important for our purpose to ascertain what is the composition of water-carried sewage. This was determined by the Rivers Pollution Commissioners in their first report as follows:—

TABLE XXX.  
DISSOLVED AND SUSPENDED MATTER IN SEWAGE.  
IN PARTS PER 100,000.

Description.	Matter in Solution.	Suspended Matter.			Total in Solution and Suspension.
	Total Solids.	Mineral.	Organic.	Total.	
Water-closet Towns, -	72·2	24·18	20·51	44·69	116·89
Midden Towns, - -	82·4	17·81	21·30	39·11	121·51

This shows that there is as a rule only ·116 per cent of solid matters, in solution and suspension, in water-carried sewage in this country. It must not, however, be forgotten that this solid matter is of an extremely putrescible character, and hence the danger of untreated sewage, especially in cases where there may be in addition large numbers of dangerous pathogenic bacteria, or disease-germs. The

problem is to remove from the sewage and render innocuous the whole of this decomposable organic matter (small though it is in proportion to the large volume of water in which it is carried), and also to destroy the dangerous germs which are carried in it, and which, if allowed to mix with the air we breathe or the water we drink, become so dangerous to our health and lives.

Up to the present date the following may be taken as **the various methods of sewage-disposal** which have been tried:—

- (1) *Outfalls into the sea, estuaries, or large rivers*: in other words, disposal by dilution.
- (2) *Treatment of the sewage with various chemicals in tanks or otherwise*: in other words, disposal by antiseptic treatment or precipitation.
- (3) *Filtration through artificial filters* of various kinds, or through land: in other words, disposal by mechanical separation of the solids, and by nitrification.
- (4) *Broad irrigation*: in other words, using the sewage for manurial purposes on land, and at the same time purifying it by filtration and nitrification.
- (5) *Septic or natural decomposition*: in other words, allowing natural decomposition to act on sewage and to break up and destroy the solids, and allowing nitrification to purify the effluent.

## CHAPTER II.

### OUTFALLS INTO THE SEA, ESTUARIES, AND LARGE RIVERS.

Under certain circumstances and with proper precautions, **the discharge of crude sewage into the sea** can be carried out in a satisfactory manner without danger of any nuisance, and such a disposal has much to recommend it. All towns situated on our coasts deal with their sewage in this manner, and it is only where the outfalls have been badly selected that any evils result. There are many scientists who contend that this is a wasteful practice, and that the valuable manure contained in sewage should be returned to the land from whence it originally came in the form of food; but hitherto it has been found that, owing to the enormous dilution by water of the more valuable manurial products in sewage, it is more economical to dispose of sewage in the most rapid and sanitary manner and deal with the land in other ways.



The essential points to be considered in dealing with this method of sewage-disposal may be briefly stated. The outfall must be carried well below the low-water mark of the lowest known tide; otherwise a nuisance is very likely to be caused. It must also be carried to such a point that the incoming tide or wind will not bring the sewage back upon the shore, and that the sweep of any currents in the locality will not have the same effect upon adjacent coasts.

In order to obviate such a possibility, and also to ensure that the point of outlet is so selected that the sewage will always, under all conditions of winds and tides, be carried well away to sea and not coast along any neighbouring shores, **very careful and complete float-observations** must be carried out under all possible conditions of wind and tide. These observations must not only be made with surface-floats, but also with submerged floats at different levels, and the various tracks or courses which these floats take must be followed and marked upon proper charts. When the most suitable spot has been thus determined, it may be found that even then it will not be safe to allow the sewage to flow continuously, but that it must be stored in tanks and only allowed to flow at some particular level of the ebb-tide. It is almost unnecessary to add that the culvert conveying the sewage to the submerged point of outlet must cause no obstruction to the navigation along the shore, and that it must be so marked with buoys or "perches", or be so visible both by night as well as day if necessary, that no accident to boats or shipping will occur.

It is no part of this article to enter into any details of engineering construction, but it may be well to give the following description of **the outfall works at Portsmouth**, as they afford an excellent example of a well-designed and carefully-constructed sea-outfall, carried out under the conditions which have been enumerated. The daily dry-weather flow of the sewage of Portsmouth is about 4,500,000 gallons. The whole of the borough and surrounding district is exceedingly flat, and for some miles the land only reaches a height of a few feet above the high-water mark of spring-tides. The sewage therefore has to be pumped. The Isle of Wight is opposite, and there is no promontory along the coast near to Portsmouth which could be selected for a suitable outfall. A reference to the plan (fig. 424), however, will show that there is a large land-locked harbour, called Langstone, situated about two miles to the east of Portsmouth, which at high water is filled with an enormous volume of water, and this water, as the tide falls, rushes through the narrow channel communicating with the sea; this narrow channel naturally suggested itself as a suitable locality for the outfall. Numerous and extended float-observations confirmed this opinion, as it was found that floats of all descriptions were without exception carried well away

to sea, if placed at this point *about one hour after the flood-tide had turned*. The plan clearly shows the value of these float-observations, as not only was a

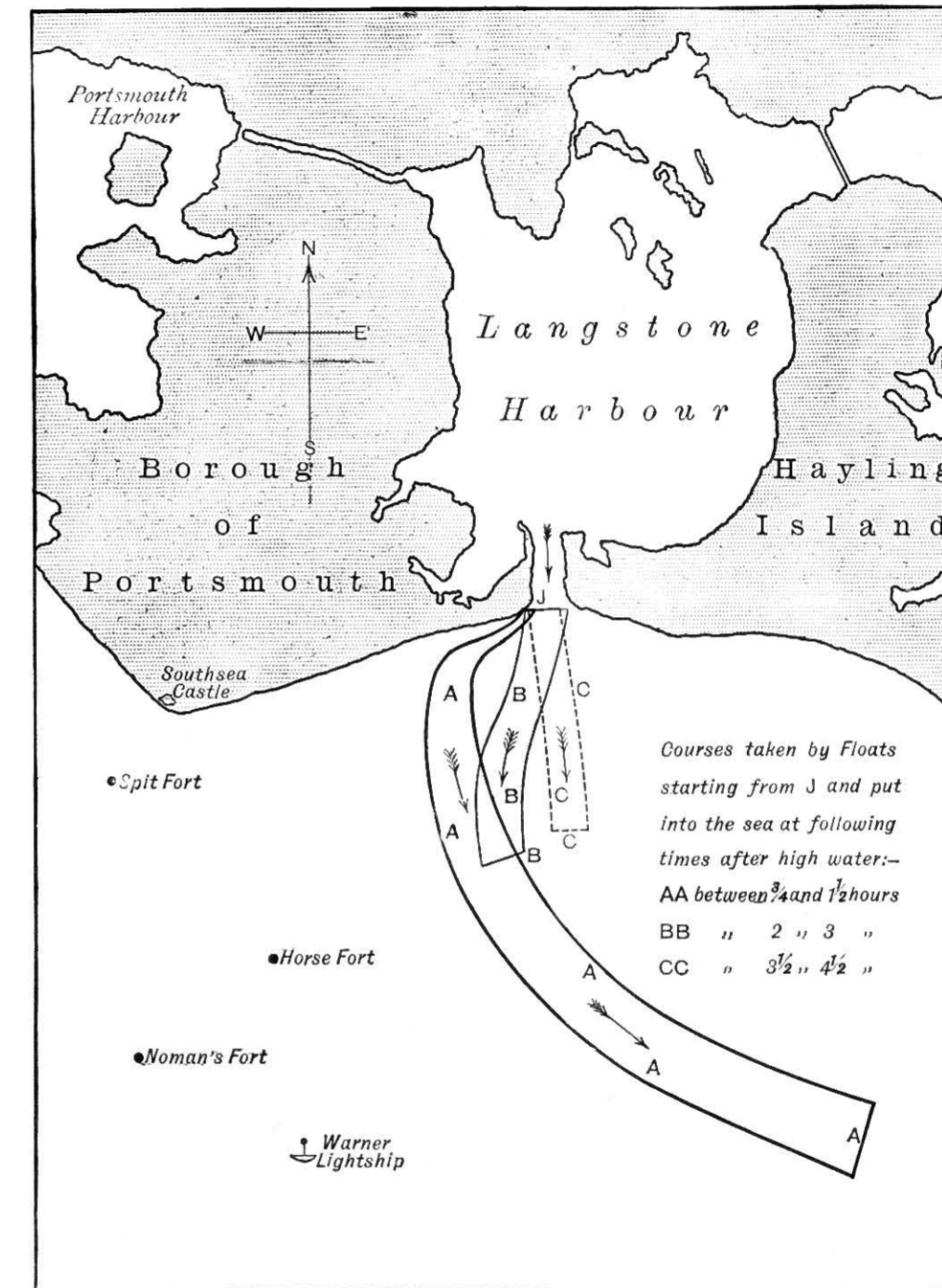

Fig. 424.—Borough of Portsmouth: Sewage-outfall Works. Plan showing float-observations taken from the outfall.

most suitable position for the outfall determined, but also the most suitable times of tide for releasing the sewage were also ascertained.

The sewage is raised at a pumping-station about a mile from the outfall, and forced along iron rising-mains to tanks close to the point of outfall. There are three of these tanks placed side by side, with a collective capacity of 4,500,000 gallons, and covering an area of  $3\frac{1}{4}$  acres. Each tank is 160 feet in length and 150 feet in breadth, constructed of cement-concrete. They are arched over and



covered with soil and grass. The invert is segmental in cross section, with a longitudinal fall of 1 in 150 to the outlets. In order to allow the whole of the contents to be discharged within about an hour and a half of high water, the level of the invert has been placed one foot below ordinary high-water mark.

The quick discharge of the contents of these tanks is a special feature of the scheme, as it has to be accomplished in about three-quarters of an hour. The tanks first discharge into a culvert, seven feet by six in size, from which three lines of cast-iron pipes three feet six inches in diameter are carried well into the tide-way, their mouths being just below low-water mark.

The arrangement by which the large penstocks, which let the sewage from the tanks to the culvert, are opened, is very ingenious. At the moment when the discharge ought to take place, a man opens a small penstock from the top of the tank, the escaping sewage from which operates a turbine, which sets in motion the machinery by which the large and heavy penstocks are opened, thus liberating the sewage in large volume, and with a very small expenditure of time and labour. These works and outfall have been in successful operation for the past eight years, and no nuisance or trouble of any kind has been occasioned thereby. They were designed and carried out by Sir Frederick Bramwell and Mr. Graham Harris, and are the best example of a successful sea-outfall with which the author is acquainted.

**An outfall into an estuary** may also be successfully carried out, where the volume of water passing out to sea is very largely in excess of the quantity of sewage poured into it, and where from its velocity the sewage will be carried well past the shores and away to sea, and where no obstructive banks or bars will be formed by the detritus or heavier particles in the sewage settling on the bottom, and thus perhaps causing serious obstruction to navigation or impediment to the flow of water.

There are many instances of successful sewage-disposal into estuaries, the most notable being that of Liverpool, which pours nearly the whole of its sewage in a crude state into the river Mersey. The dry-weather flow of this sewage amounts to about 10 million gallons in twenty-four hours, but owing to the large volume of water entering the Mersey at each tide, and the quick velocity of the flow of the ebb-tide, no trouble has ever occurred during the great number of years this method of disposal has been practised. There are twelve outfalls of various sizes discharging their contents below low-water mark, and though the outfalls are in many cases close to the entrances of docks, no nuisance whatever has arisen.

**Outfall into a river** is to be deprecated except under very exceptional cir-

cumstances, such as when the river consists of a very large volume of water, and where the water below the outfall is not used for domestic purposes. Unfortunately, owing to the facilities and economy of thus disposing of sewage, it was almost universally the practice throughout this country when sewers first came into vogue, but the effects produced on the rivers, and even on the health of the inhabitants in their vicinity, were so disastrous that steps were very early taken to prevent or mitigate the nuisance thus caused, and the whole question as to the proper disposal of sewage thus began to be discussed. Unfortunately there are still many cases of river-pollution in this country by sewage and manufacturers' wastes, and the condition of many of the rivers and streams in this country is a disgrace to the Local Authorities who are responsible for their condition.

The Public Health Act (1848) did not deal with the question of **the pollution of rivers**, nor did the great Public Health Act (1875), as these acts were permissive rather than compulsory, and even the Rivers Pollution Prevention Act (1876) entirely failed in its object. The Local Government Act of 1888, which gives certain powers to County Councils to enforce the provisions of the Rivers Pollution Prevention Act, has, however, led to something being done to remedy the great evils at present existing.

Fortunately for us, Nature herself provides her own self-cleansing powers, or we should all soon suffer from our negligent uncleanness. The action of the oxygen of the air and in the water, the absorption of organic impurities by plants, and, above all, the myriads of bacteria to which the processes of putrefaction and nitrification are due, are constantly at work purifying our polluted rivers, and rendering them again fit for the use of man; but there can be no doubt that the practice of turning our waste products into rivers—and particularly small rivers and streams—is to be greatly deprecated, as numerous cases are on record where the germs of typhoid fever have been carried in rivers for long distances, and have led to outbreaks of the disease in places many miles away, where the water has been drunk. The only safe course is to adopt some method of purification on the lines hereafter laid down.



## CHAPTER III.

## TREATMENT OF SEWAGE WITH VARIOUS CHEMICALS.

The evils arising from the introduction of drains and sewers in place of the old middens and cess-pits, and the desire to prevent the waste of what was then considered to be a valuable manurial product, many years ago induced chemists and other scientific men to attempt to discover an universally satisfactory method of sewage-disposal. Many and various were the remedies suggested, and much time and a great deal of money were expended in the endeavour to find some method which would stop decomposition, and by the aid of chemicals remove or render harmless all the organic matter and dangerous organisms contained in sewage, arrest whatever was of manurial value, throw down all the matters in suspension, and at the same time allow the effluent water to escape in a wholesome condition. This was the problem, and up to the present time no thoroughly satisfactory solution has been found. It would be very interesting, did space permit, to recount the various systems of deodorization, antiseptic treatment, and precipitation, which sprang into existence and lived for longer or shorter periods. Space forbids, however, and consequently a short description of a few of those which have been most prominent, and which contain some ingenious and useful points that may afford hints and information upon this most important question, must suffice.

Amongst the earliest methods, and one which at one time had a great reputation, was Mr. Sillars's "**A. B. C. Process**". In this system, the precipitant adopted was a mixture consisting of the following ingredients:—Alum, 600 parts; animal charcoal, 15 parts; bicarbonate of magnesia, 2 parts; blood, 1 part; burned lime, 25 parts; clay, 1900 parts; magnesia, 5 parts; permanganate of potash, 10 parts; salt, 10 parts; vegetable charcoal, 20 parts.

This mixture was added to and carefully mixed with the sewage in the proportion of from 4 to 10 parts of the mixture to 1000 parts of sewage, according to the nature of the sewage to be dealt with. The treated liquid was then allowed to remain in a settling tank, until the solids were precipitated as *sludge* to the bottom of the tank, the top sewage—or "effluent water", as it is called—was then claimed to be sufficiently pure to pass into a river.

This process met with some success, but has not been very largely adopted, principally owing to the large quantity of precipitant required and the excessive amount of sludge produced. The difficulty of dealing with a large bulk of sludge will be explained hereafter. The effluent also was not everything that could be

wished, for, as in all chemical processes, difficulties arose owing to the ever-varying amount and constitution of the sewage, and the danger of what is known as "secondary decomposition" in the effluent.

Before proceeding to describe some of the "lime" processes, which are of more modern adoption, two other methods may be mentioned, namely, the Suvern and Luder's.

The **Suvern System** consists of an admixture of chalk 100 parts, coal-tar 18 parts, and chloride of magnesium 70 parts, this mixture being used in the proportion of from 10 to 15 lbs. to every 1000 gallons of sewage, and mixed therewith and allowed to stand in precipitating tanks in the usual way. It was found that this mixture acted as a very speedy precipitant, no doubt partly in a mechanical way, but the effluent was not satisfactory.

**Luder's System** consisted in mixing sulphate of iron, sulphuric acid, and plaster of Paris, with sewage in various proportions according to the class of sewage to be dealt with, but was never very successful.

We will now pass on to consider the **treatment of sewage with lime**, this material having been found to be so economical and efficient in comparison with other chemical reagents or precipitants, as to be now much more generally used than any other. Mr. Santo Crimp, M.Inst.C.E., says<sup>1</sup>:—"The purest lime should be used, *i.e.* that containing a very high percentage of calcium. Strong limes, such as those produced from gray chalk, are not nearly as efficacious as those yielded by the upper chalk (flare lime) and by the crystalline limestone of Derbyshire and other counties. The lime should be thoroughly slaked before being used; if possible, the day's supply should be weighed out and slaked on the day preceding that of its intended use. Before being added to the sewage it must be reduced to the 'milky' condition, and this may be accomplished by means of the ordinary mortar-mill or by a lime-mixer" (which Mr. Crimp proceeds to describe and illustrate).

He then goes on to state that the usual dose is one ton of the lime thus prepared to each million gallons of sewage, but that the tendency is to reduce this quantity to the smallest effective amount, for, he says, "an excess of lime in an effluent may cause it to act as a precipitant of the suspended organic matters present in the river-water, thus producing deposits which in hot weather become exceedingly offensive"; and he instances this having happened at Leicester, where land is now being acquired to deal with the effluent, in consequence of "secondary decomposition" having been set up in the river. Chloride of lime has been added to the ordinary lime in order to prevent this; and the late Dr. Tidy stated

<sup>1</sup> *Sewage Disposal Works*, by W. Santo Crimp, M.Inst.C.E.



that one-third of a grain of chloride of lime per gallon of sewage was sufficient, and that his experience enabled him to say that about 56 lbs. per million gallons of sewage was sufficient for a "sewage represented by 30 gallons per head of the population".

It may be interesting here to give an account of three sewage-precipitation works where lime is used.

*Case A.*—Lime only is used, in the proportion of 1 ton to a million gallons of sewage. The lime is made into a thin cream, which is mixed with the sewage in the pump-well, and thus gets thoroughly incorporated with it. The sewage thus mixed flows into a series of twelve depositing tanks of a total area of about  $1\frac{1}{4}$  acres, the average daily flow of sewage being about 10 million gallons. These tanks are about 6 feet deep, their cubical capacity equalling  $2\frac{1}{2}$  million gallons. The sewage passes a distance of 1200 feet through these tanks, and takes 2 hours to do it. The tanks are divided from each other by walls, over which the sewage flows. To show the amount of precipitation in these tanks, it may be mentioned that the first four tanks are cleaned out consecutively about every fourth day, the fifth and sixth about every seventh day, while the remaining six scarcely ever require cleansing, the precipitation having almost ceased before reaching them. The effluent from this process only contains about 2 parts of suspended matter per 100,000, and of these 2 parts one-half is organic matter.

*Case B.*—Somewhat similar to *A*, but 15 cwts. of milk of lime are added to the sewage; the precipitation, however, is done in thirty tanks, each tank having a cubic capacity of 50,000 gallons, or  $1\frac{1}{2}$  million gallons in all. Four tanks are simultaneously filled, taking 16 minutes, and after 20 minutes of *complete* rest the top liquid is run off through a floating exit-pipe, from which the sewage passes over a weir in a thin layer, and then downwards through a coke filter to a depth of 2 feet, after which it passes *upwards* through a similar layer. The coke in these filters is changed every 3 months. The process of drawing off from a tank takes 2 hours, hence the necessity for such a large number of tanks. The result is no better than in *Case A*.

*Case C.*—Here the sewage of 50,000 inhabitants, amounting to 2 million gallons daily, is treated with 13 cwts. of quick or 1 ton of slaked lime, and 18 cwts. of sulphate of alumina, the latter being applied first and then the lime, and a thorough mixture being made in a tank. The treated sewage flows into eight tanks, arranged in parallel series, each tank being 5 feet 6 inches in depth and having a capacity of 120,000 gallons. The rate of passage is slow, owing to the large tank-capacity, amounting to nearly a million gallons. Precipitation is well effected in these tanks, as two out of the eight tanks are

emptied daily, and yield 74 tons of wet sludge. The effluent then passes on to a plot of land only 8 acres in extent, and laid out as intermittent filters, underdrained to a depth of about 6 feet. The effluent from the land is good, but might be improved if more land were used.

The failure of lime to arrest decomposition is very interesting, as showing how Nature is always trying to work by her own laws, and how difficult it is to act contrary to these laws. More will be said on this point when the question of the "septic" instead of the "antiseptic" system of sewage-treatment is dealt with, but meanwhile it may be well to briefly sketch a few more chemical processes, which have been tried from time to time with varying results.

**Hille's Process** consists of the application of the following mixture as a precipitant:—Lime, 100 lbs.; gas-tar, 3 lbs.; chloride of magnesium, 17 lbs. This mixture is made into a paste by adding 180 lbs. of water, and is added to the sewage in the proportion of from 3 lbs. to 10 lbs. per thousand gallons of sewage, according to the character of the sewage and the purity of the effluent desired. It is stated to have no better effect upon the sewage than the ordinary lime treatment.

**The Amines Process** is the invention of Dr. Wollheim, and consists of the addition of ordinary herring-brine to the lime; this addition is said to destroy all the micro-organisms abounding in the sewage. It is stated that by the action of the lime on certain organic bases belonging to the "Amine" group, a soluble gas is produced which spreads throughout the liquid, and which is antagonistic to the existence and multiplication of the micro-organisms contained in the sewage; and it was found that ordinary herring-brine, a cheap waste-product, contained "trimethylamine", the exact chemical which, in contact with lime, produces this gas so fatal to the putrefactive organisms. The proportions used are only 3 grains of herring-brine and 30 to 50 grains of lime per gallon of sewage treated, and Mr. Santo Crimp, who tried this process at Wimbledon, states that the clarification of the sewage was very rapid and complete, and that the sludge produced was inodorous, and did not afterwards become putrid. The effluent in this case was passed over land, but Dr. Klein was of opinion that the effluent was quite sterilized. It is not apparent why this process was abandoned at Wimbledon, or why it has not hitherto been largely adopted.

**Spence's Alumino-ferric Process** is also known as the Sulphate of Alumina Process, and is used with or without the addition of lime.<sup>1</sup> Messrs. Spence and

<sup>1</sup> Alumino-ferric is said to contain the following chemical bases:—

Soluble alumina, ... ..	14.00 parts.
Peroxide of iron, ... ..	.75 "
Sulphuric acid, ... ..	33.81 "
Water, ... ..	51.44 "
Total, ... ..	100.00 parts.



Sons, in a letter written to *The Contract Journal* in 1891, thus describe their methods:—"The alumino-ferric is produced in solid cakes measuring 21 inches by 12 inches by 5 inches, and weighing about 56 lbs. each. These are placed either in a stout wire cage, or a cask or box freely perforated with large holes. This is immersed in the conduit or stream of sewage leading to the precipitating tanks. As the cakes dissolve fresh ones are added. This is all the labour required, and need not occupy an ordinary labourer more than a few minutes per day. No machinery or plant of any kind is necessary beyond what we have named. We recommend in many cases the use of a small amount of lime along with the alumino-ferric. As the proportion required depends upon the character of the sewage, a few experiments with an average sample of the sewage will indicate the proper quantity. We do not recommend the quiescent system of using the tanks,—*i.e.* the plan of filling up a tank, and then shutting off the flow till its sludge has settled,—but the continuous system, the raw sewage with its proportion of alumino-ferric and lime going in at one end of the series of tanks, and the purified effluent flowing out over the last lip at the other. If there is adequate tank-capacity, complete precipitation will take place during the passage through the tanks. . . . When a cake of alumino-ferric is immersed in a stream of sewage, a remarkable change takes place in the liquid, which is quite evident on comparing a portion of it after passing the cake with a sample taken before. The sewage before passing the cake is dark and muddy, and on standing does not improve. After passing the cake, it is seen to be separated into two portions—a clear, bright, inodorous effluent, and a curdy precipitate which rapidly settles. . . . The alumino-ferric, by the action both of its bases and acids, throws down the suspended matters and destroys the smell."

This process has been fairly successful where the effluent is passed over the land; notably at Wimbledon, where Mr. Santo Crimp says of it, "nearly every known re-agent has been tried at Wimbledon, some in solution, others in suspension, and some in the form of filters of every conceivable shape, but up to the present (1890) the system now in operation has been found to best meet all the exigencies of the case".<sup>1</sup>

At Wimbledon the alumino-ferric is applied in the form of blocks about 30 inches × 20 inches × 3½ inches, piled on edge in a large wooden vessel through which a stream of water is made to pass, and the saturated solution thus formed is drawn off at the bottom of the vessel and mixed with the sewage. The proportion of alumino-ferric used in this case is about one-third of a ton per million

<sup>1</sup> *Sewage Disposal Works*, by W. Santo Crimp, M.Inst.C.E., page 219.

gallons of sewage treated, and one gallon of the solution is added to 9000 gallons of sewage. Half a ton of pure lime is also added to each million gallons of sewage, or 7·84 grains per gallon, but this amount of course varies with the different conditions of the sewage, and in very dry hot weather a small quantity (about 2 grains per gallon of sewage) of manganate of soda is added, which is stated to have a very beneficial effect in the prevention of secondary decomposition and of offensive odours. After the necessary treatment, the sewage passes into the settling tanks, and the remainder of the process is similar to nearly all precipitation-works. The effluent, however, does not pass direct into a river or stream, but is led in carriers over land, where it is further purified before entering the adjoining river.

The "Natural" Purification or Cosham's System has for its principle feature—and one which is of considerable importance—the fact, claimed to have been discovered by Mr. Cosham, that in treating sewage with any chemical, and notably alumino-ferric, the consumption of chemicals can be sensibly reduced, and their good effect extended, by prolonging the period during which contact is maintained between the chemical and the sewage, and the more effectually this is done the better the result. This is effected by means of special tanks, which Mr. Cosham has designed, and which are shown in fig. 444, page 61.

After special treatment with the requisite amount of chemicals, the sewage is conveyed by a pipe discharging into the central portion of the continuous automatic precipitating tank, where it has a downward flow which greatly assists the precipitant in its work; it then passes under the divisional wall, and rises up the portion of the tank on the other side. The central-tank effluent then passes up the flocculent-flue (which traps back the bulk of the flocculent matter, and so prevents it from passing into the divisional chambers), and so into the first of the series of divisional chambers; it then passes through each chamber in succession, having a combined flow in each, *viz.*, a downward, followed by an upward, which is obtained by the flocculent-flues, and finally is taken for filtration to the "natural" filter beds, or prepared area of ground.

In the first portion of the downward flow in the central portion of the tank, the sewage gets thoroughly and evenly impregnated with the precipitant, the precipitation actually commencing to take place about two-thirds down; and as the sewage rises on the other side of the divisional wall, the precipitation continues, and the albuminoids in solution, on rising, are rapidly coagulated by chemical combination, and so caused to descend, leaving a clarified effluent for further treatment in the specially-constructed trapped flocculent-arresting chambers.



The bulk of the sludge precipitates in the central portion of the tank, and accumulates in the sludge-sump formed at the bottom of it. The flocculent matter precipitates in the series of divisional chambers, and accumulates at the bottom of each, more precipitation taking place in the first two or three chambers than in the later ones. The sludge from the central compartment is first extracted, and the sewage lowered in the central compartment; after which, by lifting the valves placed at the bottom of each divisional chamber, the head of effluent presses out the precipitate from the bottom of each of the divisional chambers into the central sludge-sump. It is claimed that the removal of the sludge is thus greatly facilitated over the usual methods.

The effluent is dealt with either over land, or in one of the "natural" filters, composed entirely of sand, gravel, and pebbles, arranged in layers of varying thickness and size.

This process will be again referred to when dealing with the subject of the disposal of sewage from isolated houses. It is sufficient here to say that the tanks are most ingenious, and have much to recommend them.

**The Persulphate of Iron Process** is a chemical process of precipitation in combination with lime, invented by Mr. Thomas Wardle, the author of a book on *Sewage Treatment and Disposal*, and who claims for it that organic matter in solution is precipitated together with all suspended matter, and that persulphate of iron is an unfailing germicide. A weak solution of persulphate of iron, to the extent of about 1 ton to each million gallons of sewage, is used, to which are sometimes added lime, alumina salts, and other chemicals, "according to the nature of the sewage to be treated". The sewage after being dosed is passed through settling tanks in the usual way. The author is not aware whether this process has been tried anywhere, or with what success.

**The Hermite Process** practically consists of a process to electrolyse sea-water, by electricity applied through platinum and zinc electrodes of considerable superficial area. Current at a pressure of 6 volts is passed through these plates, and certain salts rich in oxygen are the result, together with chlorine. It is stated that this chlorine can be obtained at a cost of 4*d.* in fuel for every 1000 grammes, and also that 1 gramme of chlorine every 24 hours is sufficient to deodorize and partially disinfect the sewage of one person of the population. The electrolysed solution is added to the sewage in the sewers, and it is claimed that under this process the sewage reaches the outfall in a perfectly inoffensive condition. It is stated that about 6½ lbs. of chlorine can be made every hour from one electrical horse-power, and that this quantity will purify about 14,000

gallons of sewage. A hundred horse-power would thus purify about 1½ million gallons of sewage in about 10 hours.

"This method is specially adapted to hospitals and other large public buildings. The salt-water could be decomposed in moderate-sized tanks placed on each floor, and allowed to run into the drain-system in small quantities either automatically or by hand regulation. Thus this cleanly and practically inexpensive liquid would fill the traps of the various sinks and basins, and so disinfect all the material while it was yet within the building and before it reached the city sewers."<sup>1</sup>

**Electrolysis** consists in breaking up the organic compounds of sewage into their constituent parts, by passing an electric current through iron electrodes placed in the flowing sewage, which results in the formation of iron oxides and chlorine. The first produces oxygen, and the second produces chloric acid, which destroys organic matter. A non-oxidizable carbon plate is employed for the positive pole, and iron is used as the negative pole, so that, by means of a porous diaphragm between, the component parts of the mineral salts are collected. At the non-oxidizable plate a solution of chlorine and oxide of chlorine is produced, and at the negative plate ammonia, soda, and potash are formed, which precipitate the magnesium salts and lime in the liquid. A large portion of the solid and dissolved impurities in sewage are thus deposited in the form of sludge.

**The foregoing short descriptions** of some chemical processes for the clarification, purification, or precipitation of sewage, may be taken as examples of what has been tried in these directions, and it will be noticed that in no case must it be assumed that the effluent water from any sewage that has been treated chemically has been rendered so pure as to be fit for domestic purposes, unless it has been passed over or through land in order that it may lose all propensity to again decompose.

Professor Henry Robinson, in a paper on "Sewage Disposal" which he read before a congress of the Sanitary Institute held in Dublin in the year 1885, said: "Experience shows that it is impossible at all times and seasons to be sure of a constant and uniformly high standard of purity, and that chemical works should be supplemented by a filtration area however small. The addition of this, however, enables a lower standard of effluent from the precipitation tanks to be admissible, and this can be attained with very simple and inexpensive chemicals."

Speaking of **the cost of such works**, he stated that it varied from 0·91 to 1·66 of a £ per head of the population, and that the average cost of the works he had himself carried out was 1·23 of a £ per head. The cost of treatment he

<sup>1</sup>From a pamphlet by the British Electrozone Company.



had found was from '036 to '110 of a £ per head per annum, and an average over several places gave '06 of a £ per head per annum. These figures only applied to places where the very highest standard of purification was sought to be attained; but where filtration was added, the cost of works would be about '075 of a £ per head, and the cost of treatment '04 of a £ per head per annum.

The difficulties and objections to be met with in dealing with sewage entirely by chemical processes, may be summed up as follows:—

- (1) The varying character of the sewage to be dealt with, not only in different towns but also almost hourly during each day, this being intensified where, as in most cases, the sewage contains various trade and manufacturers' refuse or wastes, which are often very refractory under the influence of the chemicals used for the treatment of the sewage.
- (2) The tendency of all chemically-treated effluents to revert to secondary decomposition, this having only been temporarily arrested by the treatment.
- (3) The first cost of the necessary works and plant, and the subsequent expense of treatment.
- (4) The disposal of the sludge which is precipitated to the bottom of the tanks.

#### CHAPTER IV.

##### THE DISPOSAL OF SEWAGE SLUDGE.

A residuum which is technically known as "sludge" remains, as already stated, in all sewage-settling tanks after chemical treatment, and the ultimate disposal of this offensive, slimy semi-fluid material is by no means an easy matter. The amount of sludge produced from a given quantity of sewage is naturally very varied, according to the quality or consistency of the sewage and the description and amount of the chemicals used in the process. For instance, it appears that the amount of sludge produced daily at Birmingham from the sewage of a thousand persons is nearly a ton (a cubic yard of sludge weighs about 16 cwts.), whereas, for the same number of persons at Chiswick, the amount of sludge is about a ton and a half, and at Leeds only a third of a ton.

The manurial value of sludge in its crude state is negligible, owing to the excess of water it contains (about 95 per cent), but when dried it is said to be

worth about as much as ordinary farmyard manure, weight for weight; consequently all serious attempts to deal with this material have been in the direction of eliminating as much of the moisture as possible.

At some sewage works the preliminary step in the separation of the liquid consists in running the sludge upon **roughly-contrived filter-beds**, composed of ashes screened from ordinary house-refuse; after a partial drying the sludge is mixed with more ashes, and when sufficiently hard and dry this "compost", as it is called, is carted on to the land and dug in as manure. This method is, however, very tedious, as in damp or wet weather the drying by evaporation is much retarded, and the handling and cartage also become expensive items.

At Ealing, near London, the sludge is mixed with the house-refuse and **burnt in an ordinary destructor**, the residuum being an innocuous and inoffensive "clinker". This method was also adopted at Salford, but the process is liable to produce offensive fumes, which must be specially dealt with.

At the Birmingham sewage-farm the sludge is simply **dug into the land**, whilst at Crossness on the Thames, where a large proportion of the London sewage is dealt with, the sludge after a partial natural drying is pumped into special hopper steamships and **carried out to sea**, where it is discharged into deep water; this latter method has also now been adopted at Salford.

The more modern method, however, of dealing with this necessary evil of all chemically-treated sewage, is to **pass it through a "filter-press"**. The plant necessary in this case is a steam or other engine, working an air-compressor of such capacity as will compress the required amount of air to a pressure of about 100 lbs. on the square inch. The filter-press is usually made of vertical cast-iron plates, with recesses on each face and projecting rims, so that when pressed together there is a space between. The surface of each plate is furnished with cloths of jute, hemp, canvas, felt, or some such material, acting as a filtering medium.

Fig. 425 shows the general appearance of a filtering-press of the pattern supplied by Messrs. Manlove & Alliott of Nottingham. The sludge is forced through the centre of the fixed end into the chambers between the plates, where the pressure is maintained until nearly the whole of the moisture has been forced through the filtering-pads and flows out by openings at the lower edge of the plates. When water ceases to flow, the hand-wheels are loosened, and the end frame is moved by the piston acted on by the compressed air, and the plates are separated one from the other by sliding them along horizontal shafts. The sewage-cakes, which have thus been formed between the pairs of plates, drop out,



as the plates are moved, into a truck or other receptacle placed under the press, and are removed to a suitable shed for sale as manure. The press is again closed, and the process of pressing resumed. Such a press as has been described is capable of turning out from 20 to 25 tons of cake per diem, at a cost of about 10*d.* per ton, the cake containing only about 50 per cent of moisture. About 5 tons of sludge can be pressed into one ton of cake, and this if dried and

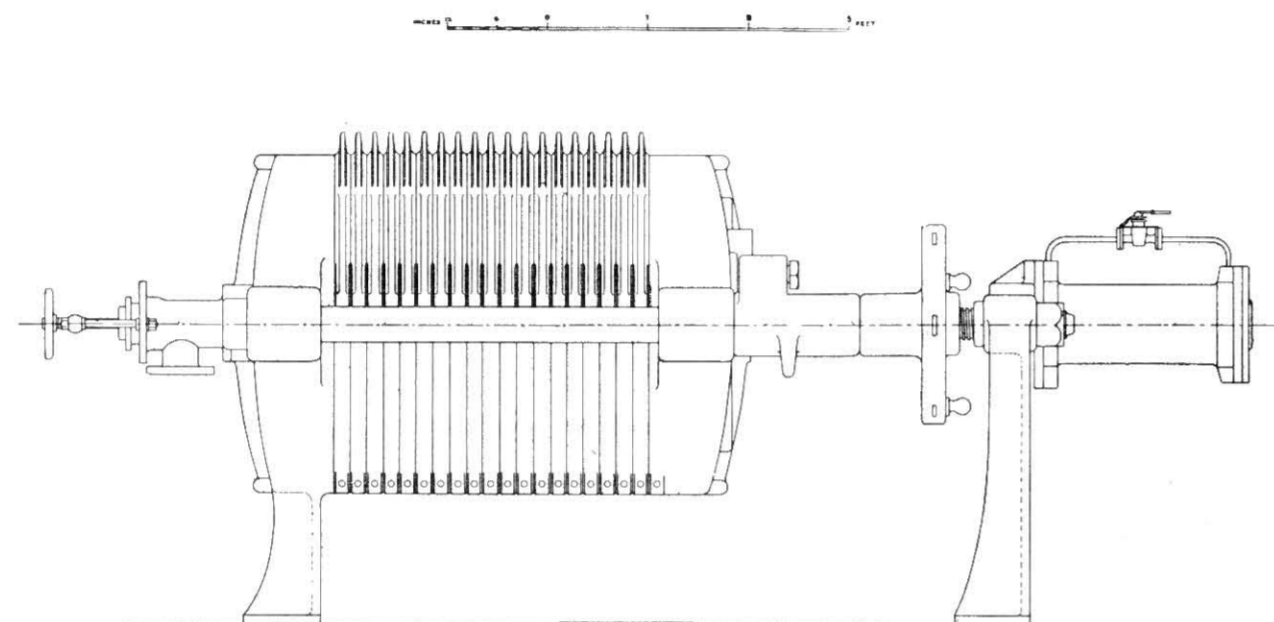

Fig. 425.—Elevation of Manlove and Alliott's Filter-press for Sewage Sludge.

pulverized can be sold for about 2*s.* per ton. These figures will of course vary with the description of sewage dealt with and the chemicals employed, but it may be well to point out that it is generally found necessary to add from 3 to 5 per cent of lime to the sludge before pressing it, in order to prevent subsequent decomposition.

In concluding these remarks upon the disposal of sludge, the author will describe the methods at present adopted for the **disposal of sewage sludge at Manchester**. The present production of sludge is about 250 tons a day, but when the whole of the sewers are connected with the main drainage system, the amount will be about 510 tons per day, and ultimately, owing to increase of population, about 624 tons. When the sewage has been run continuously through a precipitation-tank for a period of from two to three days,—varying according to the weather and the character of the sewage,—the penstocks are closed, and the sewage in the tanks is carefully decanted by means of floating arms, the sludge being left at the bottom of the tank. Valves connecting with the sludge-well are then opened, and the sludge gravitates, with the assistance of manual labour, into the well, from which it is pumped into the sludge-pits adjoining the lime-house. About two per cent of fresh lime is added to the

sludge by hand as it passes to the pits, in order to break up the glutinous matters it contains and render it fit for pressing.

The pressing is performed in the following manner:—A valve is opened at the bottom of the sludge-pit, and the sludge is admitted into one or more of the vertical iron sludge-rams, which are placed under the press-house, and may be compared to the modern aerated-water syphon. When the rams are full of sludge, air under pressure of about 90 lbs. per square inch is admitted and forces the contents into the filter-presses, which are placed on the first floor of the building. Each press contains 44 ribbed vertical plates, 41 inches square, resting on a horizontal frame, upon which they are free to slide. These plates are covered on both sides with coarse cloth, specially manufactured for the purpose. The sludge under pressure is admitted between the cloths, through which the moisture percolates and passes away to a covered tank by openings at the bottom of the press, the solid portions remaining between the cloths. The presses are opened and closed by hydraulic pressure. Each pressing takes about 55 minutes, and leaves a deposit of cake about an inch and a half in thickness between the cloth-covered plates.

The present filter-presses, eight in number, produced during the year 1895 an average quantity of 738 tons of pressed cake per week, at a cost of 2*s.* 11*·*9*d.* per ton of cake produced, equal to 9*·*7*d.* per ton of wet sludge. The cost of pressing is based upon the returns of the manager. For some time after the works were put in operation, the cost was at the rate of 3*s.* 6*·*6*d.* per ton of cake produced, equivalent to 11*·*5*d.* per ton of wet sludge. The weight of cake produced by each pressing is about 1¼ tons. The liquid passed off from the presses equals about fifty per cent of the bulk, or about three-fourths the weight of the wet sludge. This liquid contains a large proportion of polluting matter, and is pumped back to the precipitation-tanks for re-treatment. The weight of wet sludge resulting from one million gallons of sewage is about 24 tons, or 6*·*5 tons of cake, the proportion of wet to pressed sludge having varied between 3*·*71 to 1 and 3*·*25 to 1, since the opening of the works in January, 1894. It is difficult to assign any definite reason for this variation in the consistency of the sludge, but it may possibly arise from the admission of trade-refuse into the sewerage-system through old sewers recently connected. Furnace-ashes are at times brought down with the sewage, and the bulk of this material is occasionally so great that it can be separated from the sludge and removed to a tip without pressing. The estimated future production of wet sludge is 624 tons per day, equivalent to 168 tons of cake.

The cakes are dropped from the presses through a hopper into wagons, and



conveyed to a tip formed by the disused bed of the river Mersey, which formerly passed through the works. A proportion of the pressed sludge, amounting to about 17,598 tons per annum, or an average of from 40 to 50 tons per day, is at certain periods of the year removed by farmers in the locality.

It is stated that the present tip, formed by the old river wall, will at the present rate be shortly filled up, so that the Corporation of Manchester are proposing to purchase a steam barge, of about 750 tons carrying capacity, for the purpose of conveying the sludge in a wet condition to sea about 30 miles from the entrance of the Ship Canal, or a total distance from the works of about 60 miles, at a cost of nearly 9*d.* per ton of wet sludge.

Such are the difficulties connected with the sludge question, that "bête noir" of all precipitation-systems, and we will now proceed to discuss some other methods of dealing with the disposal of sewage.

---

## CHAPTER V.

### FILTRATION THROUGH ARTIFICIAL FILTERS AND THROUGH LAND.

Many were the early efforts to purify sewage by passing it through **mechanical filters**, either stationary, joggling, or rotating, but all these attempts, it is needless to state, were entirely unsuccessful, and experience has shown that it is impossible to artificially filter sewage, except through land or carefully-prepared bed-filters of suitable materials, and even then it is necessary to first deal with the sewage by some chemical or other process, in order to get rid of the sludge before reaching the filter, as otherwise this is soon choked and rendered inoperative.

It is true, however, that partially-successful purification of crude sewage has been obtained by what is known as **Intermittent Downward Filtration**, where a sufficient amount of suitable light land has been employed, but, in such a case, the treatment may be compared to broad irrigation. The land, however, in the former case is usually drained to a greater depth (6 or 8 feet), the drains are more frequent, and the soil (which must be of an exceptionally light nature) well broken up to receive the sewage. Where a large quantity of sewage has to be dealt with, in some cases equivalent to the sewage of a thousand persons per acre,<sup>1</sup>

<sup>1</sup>The eminent engineer, Mr. Mansergh, states that no more than the sewage of 700 persons should be put upon one acre of land drained six feet deep. (Vide *Minutes of Proceedings of the Institution of Civil Engineers*, vol. xlix. page 190.)

the land is not cropped, and the surface is frequently turned over in order to revivify it. No successful downward filtration of sewage through land or other materials can take place, however, unless the filtering medium is allowed to rest at intervals, in order that air, the great restorer, may enter the pores, and oxidize or burn up the organisms which have been at work eating up and destroying the organic matters in the sewage; and very little successful purification can take place, unless the sewage has previously been deprived of its heavier and slimy ingredients by some chemical or other precipitation process, as otherwise the sludge will eventually choke not only the surface of the filter, but sometimes even the interstices, and thus render the filter totally inefficient.

Dr. Frankland, in the First Report of the Rivers Pollution Commission, says, with regard to the filtering power of soils: "These results show how rapidly the process of nitrification (the conversion of ammonia and animal organic matter into nitrates) takes place in the Beddington soil, and how satisfactorily the sewage is purified, even at the rate of 7.6 gallons per cubic yard of soil per diem. But when this rate was doubled, the nitrification ceased, and the pores of the soil became blocked up, so that they would no longer transmit the whole volume of sewage applied and also afford time for aëration."

The limits of this article will not permit any further reference to intermittent downward filtration through natural soils; suffice it to say that good results can be obtained if the sludge is first removed from the sewage, and time is given to thoroughly aërate the filter before a fresh application of sewage is made. Dr. Voelcker says: "A well-drained and fully-aërated soil burnt up, or, in chemical language, oxidized most perfectly, the putrescible and nitrogenous organic constituents of sewage, and transposed them into nitrates and other final products of the decomposition of animal refuse matters, products having no smell, colour, or injurious properties".<sup>1</sup>

More will be said in due course upon these points when the question of irrigation is being considered.

**Filtration through artificial substances** has been rarely if ever successful with crude sewage, and is employed only where the effluent water (after the solids have been precipitated or arrested) cannot be passed over or through suitable land. **The system of Mr. Ernest Bell** is of this kind, and may shortly be described. After the sewage has been precipitated in tanks by a special preparation of alumina and protosulphate of iron, the effluent is passed through filters containing "Magnetone", an insoluble impure magnetic oxide of iron of a very porous nature, which is said to have the property of oxidizing noxious matter during

<sup>1</sup>Vide *Minutes of Proceedings of the Institution of Civil Engineers*, vol. xlix. page 191.



the passage of the sewage through it. Fig. 426 is a section of this filter. Mr. Bell's system was tried at Salford with, the author understands, very fair results.

It is almost needless to recapitulate the various **filter-beds of coke and other materials** which have been tried with various success. The whole point seems to be that atmospheric oxygen should have frequent and free access to the

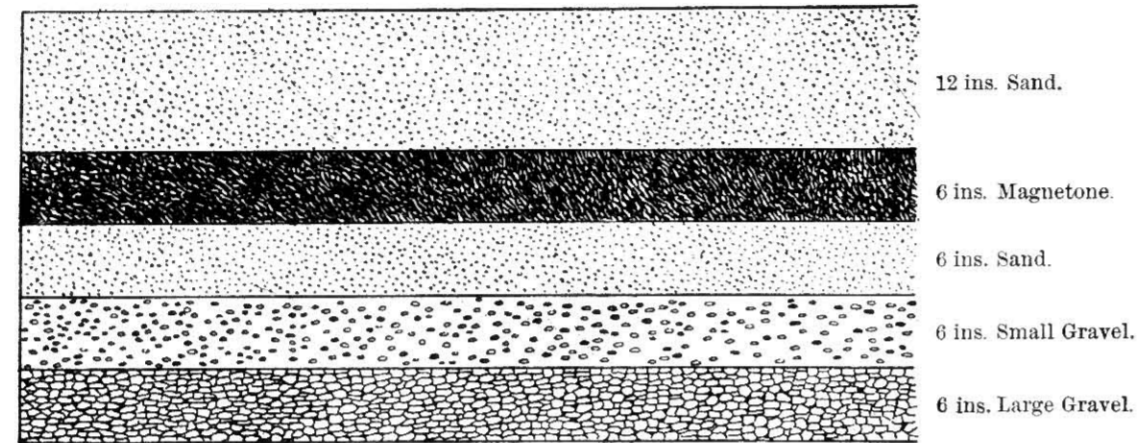

Fig. 426.—Section of Sewage-filter composed of Sand, Gravel, and Magnetone.

interior pores of the filter, and where this can be achieved, it is possible to effect a considerable amount of purification. This important point of the revivifying action of oxygen will again be dealt with.

The **Scott-Moncrieff System** consists principally in passing the sewage upwards through a filtering medium about 14 inches deep, composed of successive layers of flint, coke, and gravel. This is simple filtration, and the action is dependent upon the bacteriological theory that certain microbes, under favourable conditions, are capable of indefinite multiplication, and that these microbes or bacteria exist in all sewage, and are capable of peptonizing the solid organic matter, or in other words, that nature has provided its own means for the purification of its refuse. This important discovery will be considered hereafter.

The "**Polarite**" or "**International Water and Sewage Purification Company's**" Process is *par excellence* the most complete chemical-*cum*-filtration process at present existing. The sewage is first of all treated with Ferozone, a patent composition containing ferrous iron salts, salts of alumina and magnesia, and finely-divided very porous magnetic oxide of iron, which is said to materially assist precipitation of the solids contained in the sewage. The effluent, after subsidence of the sewage in tanks, is taken through the polarite filter-bed, a section of which is given in fig. 427. The effluent sewage from the precipitating tanks is allowed to flow on to the filter over the weir-boards, and passes through the filter-beds at such speed as will effectually purify and clarify the effluent.<sup>1</sup>

<sup>1</sup> At Swinton, near Manchester, this rate is about 650 gallons of effluent per 24 hours, per square yard of surface of filter.

The following is an analysis of this filtered effluent, made by the eminent chemist, Sir Henry E. Roscoe:—

TABLE XXXI.  
ANALYSIS OF SEWAGE-EFFLUENT AFTER PASSING THROUGH  
A POLARITE FILTER-BED.

	Grs. per Gallon.	Parts per 100,000.
Chlorine, ... ..	4.480	6.400
Free ammonia, ... ..	0.284	0.407
Albuminoid ammonia, ... ..	0.018	0.022
Oxygen absorbed from permanganate in 4 hours,	0.228	0.325

The results of this system of sewage-purification, as carried out at Acton and

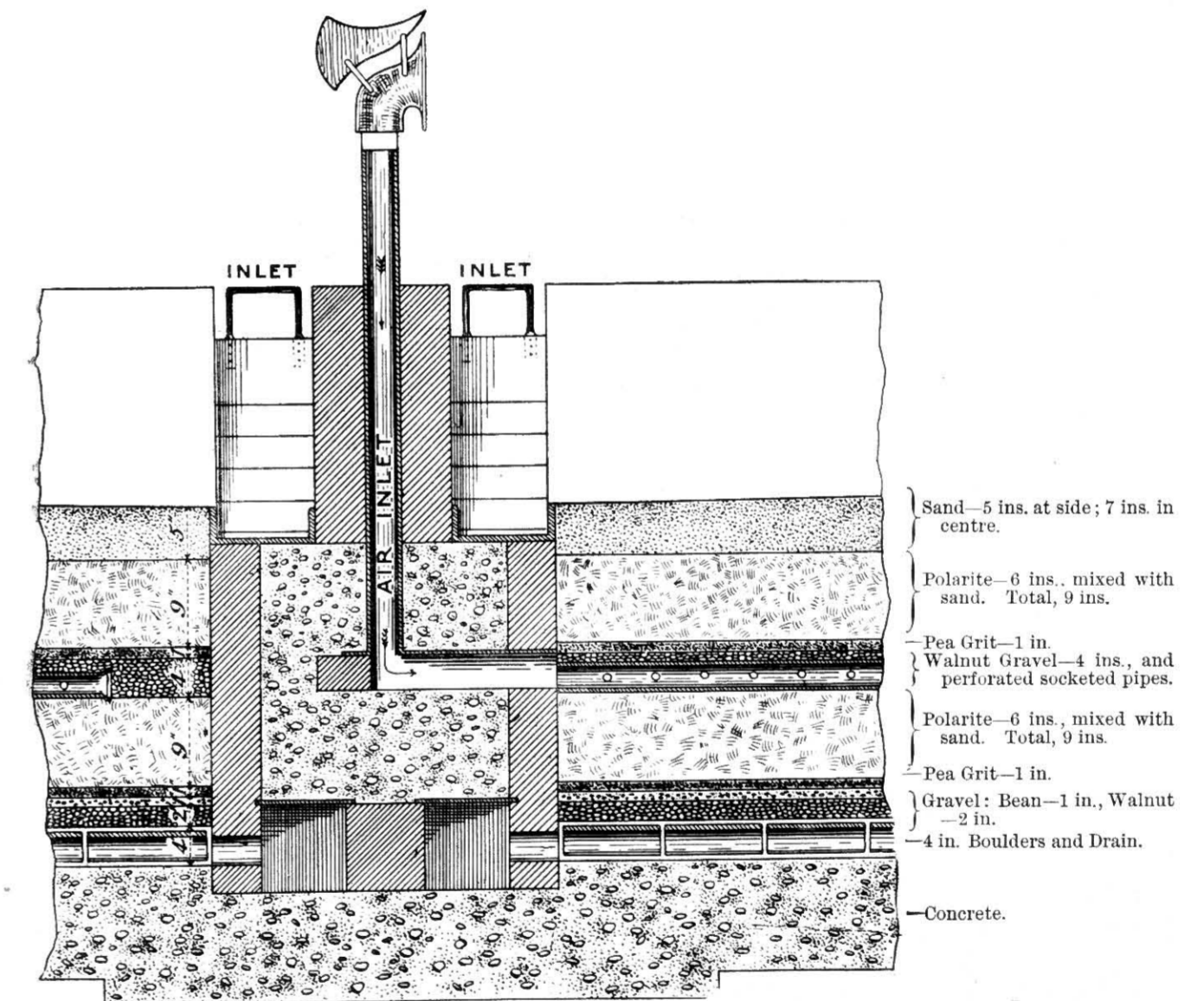

Fig. 427.—Section of Part of a Polarite Sewage-filter.

elsewhere, are said to be highly satisfactory and economical in working. It appears to be essential with these filters, as with all others, that periods of rest must be given to the filters to ensure satisfactory results.



**Lowcock's System of Sewage-Filtration**, as designed by Mr. Sidney R. Lowcock, A.M.I.C.E., is now carried on by the Sewage and Effluent-water Filtration Company. The object of this system is the rapid removal of the dissolved oxygen in a filter to assist nitrification. The matters in suspension are precipitated from the sewage before its application to the filter, to prevent, as far as possible, the clogging of the surface. The sewage is then run evenly on to the surface of the filter by means of sunk channels. The top layer of the filter is of sand, which retains any matters left in suspension, and only permits the liquid to pass slowly down into the body of the filter. After passing through the sand, the liquid travels somewhat faster in thin films over the grains of the coarser material below, and thus presents an enormous surface to the purifying organisms and to the air contained in the interstitial spaces.

The air is supplied continuously into the body of the filter by a blower,

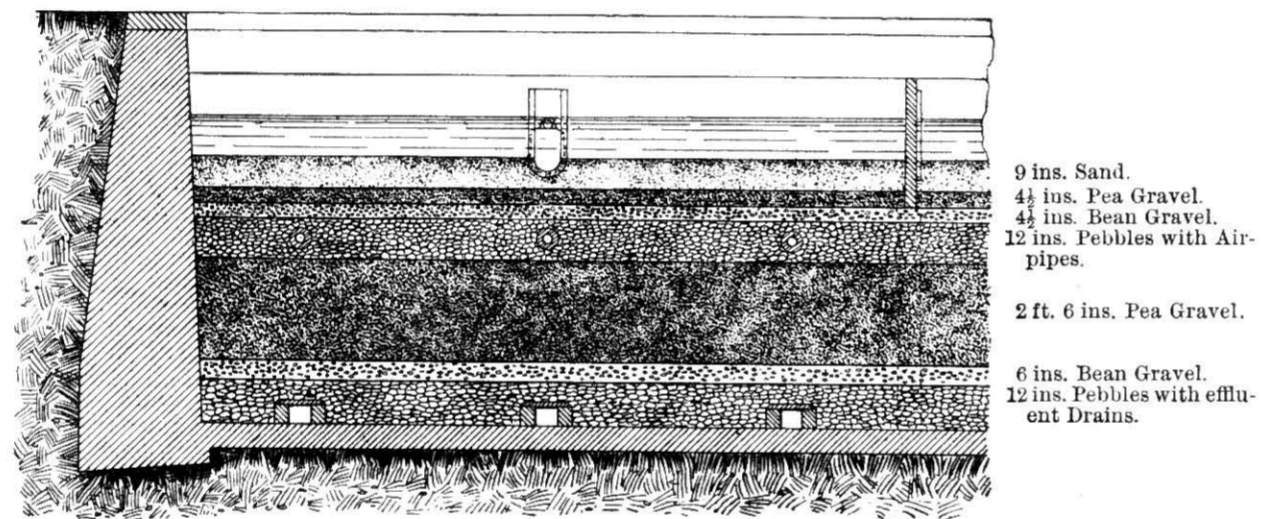

Fig. 428.—Lowcock's Sewage-filter: Section of one Division of Filter-bed. Scale  $\frac{1}{4}$  in. to a foot.

which discharges it through perforated pipes into a specially porous layer in the upper part (see fig. 428), from which it is distributed through the whole filter, and passes down and out with the purified liquid through the under-drains. The result of this is that the aëration, which is the all-important feature in filtration, is rendered entirely independent of the surface, the filter is worked continuously, and the depth can be increased and the necessary area thus reduced. At the same time, the ample supply of air prevents the deoxidizing of the nitrates already formed, a process which, in the absence of air and the presence of organic matter, proceeds far more rapidly than the nitrification process. It is estimated that  $1\frac{1}{2}$  horse-power will be sufficient to supply the air necessary for the purification of a million gallons of sewage.

Frost does not affect the operation of the filter,—except in a very small degree by lowering the temperature and thus reducing the action of the bacteria,

—as the surface is always covered with a sufficient depth of sewage to prevent it being frozen, and the sewage can pass under any ice formed, and down through the filter without hindrance.

The surface is divided up into small areas by divisions extending a short distance below the top layer of sand, as shown in fig. 428. The liquid to be filtered can thus be diverted at will from any of these spaces by shutting down the sluices in the divisions, so as to allow of the surface of any section or sections being cleaned, without interfering with the working of the lower part of the filter. Of course the more efficient the preliminary precipitation, the less frequently this cleansing has to be performed, but its neglect does not impair the purity of the effluent. If the surface is allowed to become clogged the quantity passed is reduced, but the time occupied in passing is increased, and the purity of the resulting effluent is increased also.

It is claimed for this filter that it absolutely purifies the effluent and renders it sterile. The following table of analyses represents the result of the working at Wolverhampton. All the analyses were taken from an average of 13 hours' flow, the liquid to be analysed being collected continuously for this period; the collection of the filtrate was started six hours after that of the tank effluent.

TABLE XXXII.

ANALYSES OF TANK AND FILTER EFFLUENTS: LOWCOCK'S SYSTEM.

Date.	TANK EFFLUENT.						FILTER EFFLUENT.					REDUCTION PER CENT.				
	Parts per 100,000.					Grains per Gallon.	Parts per 100,000.								Grains per Gallon.	
	Free Ammonia.	Albuminoid Ammonia.	Nitrates and Nitrites.	Oxygen consumed.	Chlorine.		Free Ammonia.	Albuminoid Ammonia.	Nitrates and Nitrites.	Oxygen consumed.	Chlorine.	Free Ammonia.	Albuminoid Ammonia.	Oxygen consumed.		
1895.																
July 18.	6.0	.6	traces.	1.9	24.5	1.43	.081	2.56	.6	24.4	75.6	86.5	68			
August 3.	6.0	.7	...	4.6	22.3	1.2	.084	2.72	1.4	22.4	80	88	70			
October 8.	4.0	.35	traces.	1.7	14.0	1.20	.07	2.68	.40	16.8	70	80	77			

**Sand and gravel alone** do not make very efficient sewage-effluent filters; fine cinders or coke should be interposed, as shown in fig. 429. A filter of this description will successfully filter sewage-effluent at the rate of 500 gallons per diem per square yard of surface-area, with a head of 4 feet 6 inches of fluid upon its surface, but of course it must have periods of rest to revivify it, varying according to the work it has to do and the degree of purity to which



it is expected to act. The top surface of sand must occasionally be cleared off to a depth of half an inch, which can then be worked and replaced. Such a filter, with proper treatment, will continue for some years to produce a satisfactory effluent.

There can be no doubt that **filtration of the effluent of crude sewage**, where the solid matters have been deposited or arrested, may be successfully

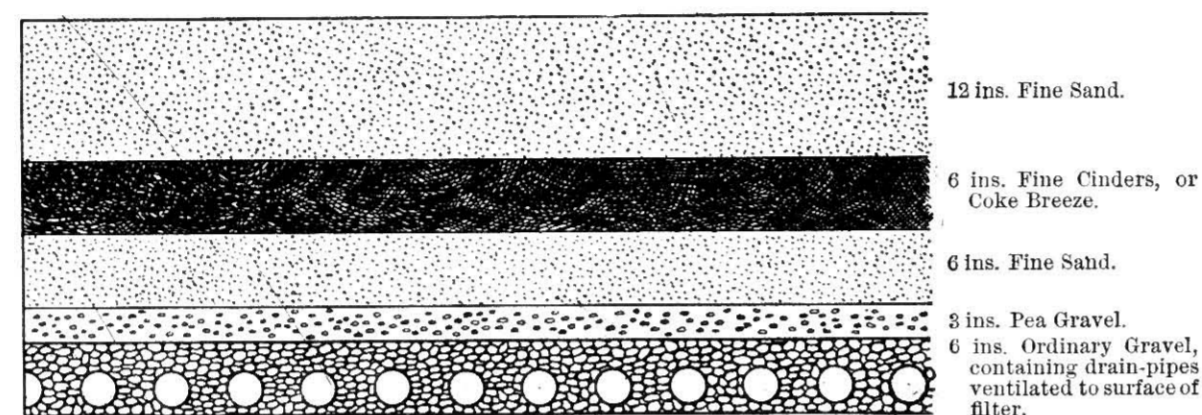

Fig. 429.—Section of Sewage-filter composed of Coke and Sand.

carried out, and indeed it seems almost essential to the process of sewage-purification that, whatever chemical or other process is resorted to, the effluent must undergo some sort of filtration before it can be raised to a proper standard of purification. Not only must the solid matter be arrested before passing on to the filter-beds, but also the flocculent particles, which otherwise will spread themselves over the surface of the filter, and in a short time stop the passage of the liquid into the filter and thus render it inoperative.

## CHAPTER VI.

### BROAD IRRIGATION.

The disposal of sewage by **Broad Irrigation**, so called to distinguish it from Intermittent Filtration, finds considerable favour with a great number of sanitarians, on the reasonable grounds that what is taken off the land ought to be put back on it, and that nature demands such a "circle of events". There can be no doubt that, theoretically, it is quite right that there should be no waste, and consequently the cry of "our sewage to the land or there will some day be no bread or meat" has much to commend it. Unfortunately the tendency of all civilized nations to congregate together in large centres makes it difficult to

carry this worthy object into effect, and the difficulty of securing suitable and sufficient land within a reasonable distance of any large town or city makes it in some cases almost impossible, except at prohibitive cost, to dispose of the sewage by broad irrigation. The enormous bulk of sewage which has to be treated, its low manurial value owing to its dilution with water, its varying quantity with changes of the weather, and its unceasing flow day and night and at all seasons of the year, tend to complicate the problem of sewage-farming to such an extent as to make this method of dealing with sewage very unpopular except under exceptional circumstances. So far as experience can at present enlighten us, it is evident that commercially-successful sewage-farming is unknown, and that it is difficult enough, even under the most favourable circumstances, to deal with large quantities of sewage, especially during rain-storms, upon sewage-farms in a satisfactory manner, so as to secure an effluent which will not pollute in some measure the stream or river into which it flows. Dr. Lissauer after many experiments says: "The effluent water of irrigation-works ought not to be compared with good drinking-water, since it must nearly always contain some ammonia, often nitrates and nitrites, and always a certain amount of chlorine, which is almost completely unabsorbed by the soil".<sup>1</sup>

No doubt there are many instances **where there is sufficient land** available to so manipulate the sewage that portions of the land may be given intervals of rest, which revivifies them in such a manner that a very high standard of purity of effluent can be maintained, but these are fortunate circumstances not enjoyed by the majority of sewage-farms.

No hard-and-fast lines can be laid down as to **the quantity of land** necessary to ensure a successful sewage-farm. Much depends upon the character of the soil, whether light and loamy, or heavy and composed of clay. Much, too, depends upon the manner in which the farm is levelled, laid out, and drained. Much depends upon the climatic influences, and upon the quantity and quality of the sewage.

At Altrincham the sewage from a population of some 10,000 persons was dealt with on 10 acres of land for some months, and for many years the sewage of 11,000 persons was successfully dealt with upon only 47 acres of land. At Abingdon, 20 acres receive the sewage from 10,000 persons, and this form of sewage-treatment is still to the front. At the sewage-farm at Clichy, where the sewage of Paris is dealt with, about 9 million gallons of sewage per acre per annum are successfully dealt with, and in one case 35 million gallons were dealt with on one acre of land in two months.<sup>2</sup>

<sup>1</sup> Vide *Minutes of Proceedings of the Institution of Civil Engineers*, vol. lxxvii. p. 356. <sup>2</sup> *Ibid.*, vol. xxxix. p. 380.



The following table shows very approximately **the amount of sewage** which is dealt with upon various sewage-farms. but these amounts are of course largely varied in times of heavy rain.

TABLE XXXIII.

NUMBER OF GALLONS OF SEWAGE DEALT WITH PER DIEM ON  
VARIOUS SEWAGE-FARMS, PER ACRE.

Name of Place.	Gallons of Sewage dealt with in 24 hours per acre.	Nature of Soil.
Abingdon, ... ..	5,000	Loam.
Edinburgh, ... ..	10,000	Subsoil of sea-sand.
Banbury, ... ..	2,300	Stiff loam upon clay subsoil.
Cheltenham, ... ..	2,760	Clay.
Bedford, ... ..	4,516	Rich loam with gravelly subsoil.
Blackburn, ... ..	16,000	Light loamy soil upon gravelly subsoil.
Chorley, ... ..	5,747	Poor vegetable soil with stiff clay subsoil.
Doncaster, ... ..	5,217	Light sandy soil.
Leamington, ... ..	2,950	Fine loam on gravelly subsoil.
Merthyr-Tydfil, ... ..	14,000	Fine loamy soil with gravelly subsoil.
Rugby, ... ..	6,153	Gravelly soil upon clay subsoil.
Tunbridge Wells, ... ..	3,000	Stiff loam and light subsoil.
Warwick, ... ..	5,185	Stiff clay.
Slough, ... ..	3,047	Sharp gravel and sand.
Barnsley, ... ..	16,886	Loam.
Aldershot, ... ..	1,960	Sand.
Croydon, ... ..	11,540	Open soil upon gravelly subsoil.
Berlin, ... ..	3,116	Sandy soil.

Professor Robinson says<sup>1</sup> that **the average cost of treating sewage on land**, at 26 sewage-farms examined by him, was one shilling and tenpence halfpenny per head of the population, or about £7, 14s. 4½d. per million gallons of sewage.

**The important points to be considered** in dealing with sewage upon the broad irrigation principle, are as follows:—

The position of the land with regard to the town, both as to locality and surroundings, and also its level, so as to avoid if possible lifting the sewage; the first cost of the land, and whether it is of suitable soil; the cost of the preparation of the land with regard to levelling, draining, and carrying the sewage to all parts of it—it is of the greatest importance that these should be carried out with great skill and perfection, as upon them, other considerations being equal, it depends whether the sewage can be properly purified or not; the choice of suitable crops and their rotation, and also whether there is a convenient

<sup>1</sup> Vide *Minutes of Proceedings of the Institution of Civil Engineers*, vol. xlix. p. 184.

market for the disposal of the produce. If there are no means of diverting the storm-water from the farm, very special means must be taken for dealing with it, as otherwise the land is overflowed at the very time when it is in a wet condition, and consequently in the worst position to receive so much liquid. There should be sufficient land, so that the various plots can be rested, not only when the crops are in a certain condition of growth, but also that the land may be revived by the oxygen of the air, which is so important in all forms of sewage-treatment.

The limits of this article prevent any discussion as to whether the produce grown on a sewage-farm, or the animals that feed on its produce, are injuriously affected by any pathological process. Suffice it to say that all attempts to prove any such injurious effects have hitherto failed, and that, with reasonable precautions and proper management, **a sewage-farm can be kept as healthy as any other farm.** Professor Forbes says: "There can be no question whatever but that, where the local circumstances of climate and soil are favourable to irrigation, and the conditions essential to its successful application properly observed, sewage irrigation is the most natural and effective system for the utilization of sewage, since it is only by this means that we can render available the whole of the ammoniacal salts, upon which so very much of the fertilizing value of the sewage depends".

There can be no doubt that the question of the disposal of the sewage of any town or building must be fully considered with all the surrounding circumstances, and each case requires careful and anxious inquiry and study before any decision can be arrived at.

With reference to **the cropping of sewage-farms**, each case must be taken on its merits as regards suitability of soil, proximity to a town, climate, and other matters. There can be no doubt, however, that a sewage-farm properly managed produces most generous crops, as witness the following table of the results of a year's working of the Walton-on-the-Hill sewage-farm, which was under the control of the author, and which is well managed by the farm-bailiff in charge. The soil is a loamy clay, and the sewage is passed over the farm as it comes from the sewers, without any chemical or other treatment. The main carriers are underground, and the greater portion of the farm is drained at a depth of about 5 feet, these drains converging into main effluent drains, which empty into the river Alt. The effluent is free from solid matter, but does not reach the standard of purity required under the Rivers Pollution Acts, a fact which is not as important in this case as in others, as the waters of the Alt are not used in any way for domestic purposes.



TABLE XXXIV.  
WALTON-ON-THE-HILL SEWAGE-FARM—RETURN AS TO CROPS AND THEIR  
VALUE FOR THE YEAR 1896.

Plots.	Crop.	Acre- age.	Quantity of Crop.	Average Price.	Gross Amount.	Per Acre.	
						Quantity.	Value of Crop.
1 & 3	Turnips,	10 $\frac{1}{4}$	Tons. cwts. qrs. 254 11 1	10 $\frac{1}{4}$ d. per cwt.	£ s. d. 217 2 8	Tons. cwts. qrs. 24 6 3	£ s. d. 21 3 8
11 & 12	Scotch Cabbage,	13 $\frac{3}{4}$	5297 dozens	10 $\frac{1}{4}$ d. per doz.	226 19 11	385 $\frac{1}{4}$ doz.	} 30 17 6
"	Do.	"	Tons. cwts. qrs. 263 9 2	9d. per cwt.	197 11 0	Tons. cwts. qrs. 19 3 1	
15	Cabbage-Savoys,	27 $\frac{3}{4}$	24 13 3	8 $\frac{3}{4}$ d. "	18 4 11	0 17 3	} 16 7 9
"	Do.	"	800 dozens	7 $\frac{1}{4}$ d. "	23 14 2	28 $\frac{3}{4}$ doz.	
"	Do. plants,	"	40,000	4s. per 1000	8 0 0	1441	
"	Rye Grass,	"	Tons. cwts. qrs. 655 16 3	7 $\frac{1}{4}$ d. per cwt.	404 16 1	Tons. cwts. qrs. 23 12 2	} 25 14 3
6	Do.	6 $\frac{1}{4}$	280 12 1	6 $\frac{3}{4}$ d. "	160 14 0	44 18 0	
4	Rye Grass and Oats,	6 $\frac{1}{4}$	234 18 3	6 $\frac{1}{4}$ d. "	129 10 5	37 11 3	20 14 6
5	Do.	10 $\frac{1}{4}$	174 3 2	5 $\frac{1}{2}$ d. "	82 14 5	16 19 3	8 1 5
10	Do.	14 $\frac{1}{2}$	581 3 0	6 $\frac{1}{2}$ d. "	316 13 6	40 1 2	21 16 10

In conclusion, the table on p. 33 will be of service as showing some of the results obtained by various methods of sewage-treatment.

## CHAPTER VII.

### THE SEPTIC AND OTHER BACTERIAL SYSTEMS.

We will now turn to a recently-discovered process, which is **almost a complete reversal of all the methods hitherto applied to sewage**, for instead of endeavouring to arrest decomposition, the object of the Septic System is, as its name implies, to favour decomposition or putrefaction, and for this purpose the sewage is confined in tanks, from which all light and as much air as possible are excluded, so that thorough and complete putrefaction may take place. In this way, the microbes of decomposition are encouraged, and they speedily multiply, and destroy the solid and flocculent matters contained in the sewage. The effluent from these tanks is then passed downwards through ordinary filter-beds of sand and coke-breeze, and is said to emerge therefrom perfectly clear and free from all decomposable obnoxious or organic matter; in fact, pure drinking-water. This remarkable discovery is the invention of Mr. Donald Cameron, the City Surveyor of Exeter, and the following description of the principles of the system, and of the requisite apparatus, is an almost *verbatim* reproduction of Mr. Cameron's own words. The apparatus is shown in Plate XV.



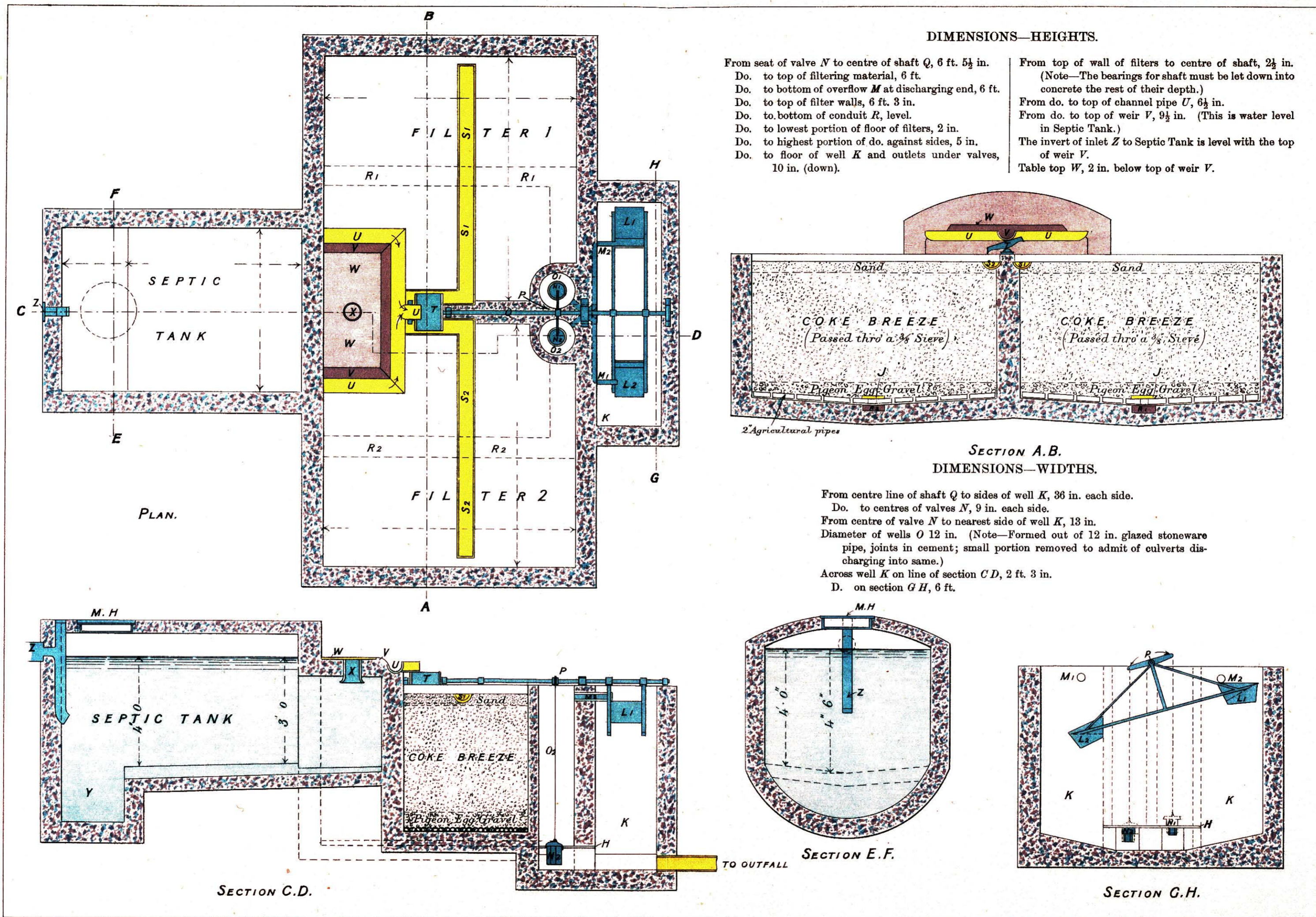

DIMENSIONS—HEIGHTS.

- From seat of valve *N* to centre of shaft *Q*, 6 ft. 5½ in.
- Do. to top of filtering material, 6 ft.
- Do. to bottom of overflow *M* at discharging end, 6 ft.
- Do. to top of filter walls, 6 ft. 3 in.
- Do. to bottom of conduit *R*, level.
- Do. to lowest portion of floor of filters, 2 in.
- Do. to highest portion of do. against sides, 5 in.
- Do. to floor of well *K* and outlets under valves, 10 in. (down).
- From top of wall of filters to centre of shaft, 2½ in. (Note—The bearings for shaft must be let down into concrete the rest of their depth.)
- From do. to top of channel pipe *U*, 6½ in.
- From do. to top of weir *V*, 9½ in. (This is water level in Septic Tank.)
- The invert of inlet *Z* to Septic Tank is level with the top of weir *V*.
- Table top *W*, 2 in. below top of weir *V*.

SECTION A.B.  
DIMENSIONS—WIDTHS.

- From centre line of shaft *Q* to sides of well *K*, 36 in. each side.
- Do. to centres of valves *N*, 9 in. each side.
- From centre of valve *N* to nearest side of well *K*, 13 in.
- Diameter of wells *O* 12 in. (Note—Formed out of 12 in. glazed stoneware pipe, joints in cement; small portion removed to admit of culverts discharging into same.)
- Across well *K* on line of section *CD*, 2 ft. 3 in.
- D*. on section *GH*, 6 ft.

THE SEPTIC TANK SYSTEM OF SEWAGE TREATMENT, SHOWING FILTERS AND ALTERNATING GEAR.

- |  |   |  |
|--|---|--|
| <i>Z</i> . Inlet to Septic Tank.                                     | <i>T</i> . Diverter.                                    | <i>N1, N2</i> . Discharging valves.                            |
| <i>Y</i> . Sump for Grit.  | <i>S1, S2</i> . Channel pipe distributors over filters. | <i>M1, M2</i> . Overflows from wells to actuating tanks.       |
| <i>X</i> . Outlet to Septic Tank.                                    | <i>R1, R2</i> . Culverts at bottom of filters.          | <i>L1, L2</i> . Actuating tanks.                               |
| <i>W</i> . Table Top.  | <i>Q</i> . Shaft.                                       | <i>K</i> . Well for actuating tanks.                           |
| <i>V</i> . Weir.   | <i>P</i> . Rocker.                                      | <i>J</i> . Brick or stone cover to culverts <i>R</i> .         |
| <i>U</i> . Channel pipe collecting effluent after passing over weir. | <i>O1, O2</i> . Wells for discharging valves.           | <i>H</i> . Cast-iron plate with seatings for valves <i>N</i> . |



TABLE XXXV.  
RELATIVE COST OF SEVERAL WORKS OF SEWERAGE AND SEWAGE-DISPOSAL, TOGETHER WITH THE RESULTS OF THE EFFLUENTS.<sup>1</sup>

Cost of construction of sewerage per head.	Method of sewage treatment.	Number of inhabitants.	Cost per head per annum of sewage-disposal, including interest on cost of construction taken at 4 per cent per annum.	ANALYSES OF EFFLUENTS.			Remarks.
				Grains per gallon.	Parts per million.	Parts per million.	
				Total solids.	Chlorine.	Free ammonia.	Albuminoid ammonia.
£1, 1s. 9d.	Broad irrigation.	500	1s. 4.3d.	—	—	—	—
16s. 2d.	Intermittent downward filtration.	1600	7.3d.	19	3.7	23.4	2.0
15s. 4d.	Ditto.	1500	5.8d.	—	—	—	—
14s. 8d.	Precipitation with aluminoferric and filtration through prepared filters, 800 gallons per square yard per 24 hours.	5000	8.9d.	68.5	9.94	29.4	1.4
12s. 10d.	Ditto, filters work at the rate of 200 gallons per square yard per 24 hours.	3000	10d.	39.6 (soluble, 29.0; insol., 10.6)	3.55	6.5	.30

<sup>1</sup> From a paper on "Sewage Disposal of Colliery Villages", by John Edward Parker, A.M.I.C.E., read at the Sanitary Congress of the Sanitary Institute held in Newcastle-on-Tyne in September, 1896.



It is significant that no difficulty seems to have arisen as to the disposal of sewage until artificial means were resorted to for the purpose. In rural districts, refuse has been largely used as manure. The larger towns, however, have steadily poured their sewage into the nearest streams, the volume of sewage often bearing a high proportion to that of the stream. In spite of the constant pollution to which they have been subjected, the rivers of Great Britain have on the whole maintained a surprising degree of purity; indeed, it may well be doubted whether, if sewage had been the only polluting matter, the question of rivers-pollution would have assumed anything like its present gravity. But the pouring of large quantities of manufacturing refuse into our rivers brought matters to a climax. The duty of maintaining a river free from pollution of every kind is now clearly recognized, and indications are not wanting that the laws prohibiting such pollution will be stringently enforced in the near future.

The contrast between the old natural way and the new artificial systems of sewage-disposal is a remarkable one. The former was no doubt rough and ready, and the pouring of crude sewage into a river does not commend itself to the educated sanitary conscience. Yet the results were not wholly unsatisfactory, for it has been abundantly demonstrated, both by ordinary observation and by scientific tests, that the sewage so poured into a river is, in many cases, completely destroyed within a few hours.

Until very recently, **the processes by which decaying animal matter gradually disappears** were little known and less understood. It was known that chemical changes occurred, but how or why was beyond the chemist's power to explain. It is now, however, recognized that many of the chemical changes which take place in organic matter are closely bound up with the life-history of micro-organisms, either animal or vegetable, generally known as microbes. There is no doubt that the disappearance of solids from sewage passed into a stream is brought about by micro-organisms. These feed on the organic matter and excrete it in a new form, its chemical composition as a rule being rendered simpler by the change. As a general rule, each species of micro-organism is poisoned or killed off by its own products; but the life-products of one species will generally serve as food for another. The breaking down of the solids in sewage thus forms a long chain of operations, though often accomplished in a marvellously short space of time.

**In the Septic system no chemicals are employed**, and there is no "treatment" of the sewage in the ordinary sense of the term, its purification being accomplished entirely by natural agencies.

**The Septic Tank itself** is merely a receptacle designed to favour the multiplication of micro-organisms, and bring the whole of the sewage under their influence. To this end the tank is of ample size, though not larger than would be necessary with chemical precipitation, and covered so as to exclude light, and, as far as possible, air. The incoming sewage is delivered below the water-level; and the outlet also is submerged with the twofold object of trapping out air, and avoiding disturbance of the upper part of the contents of the tank. On entering the still water of the tank, the solids suspended in the sewage are to a great extent disengaged, going either to the bottom or to the surface, according to their specific gravity. In the absence of light and air, the organisms originally present in the sewage increase enormously, and rapidly attack all the organic matter. By their action the more complex organic substances are converted into simpler compounds, and these in turn are reduced to still simpler forms, the ultimate products of the decomposition in the tank being water, ammonia, and carbonic acid and other gases. Other nitrogenous compounds may also be present, but they will all be soluble in a slightly alkaline solution, a condition which obtains with every normal sewage.

**No sludge is formed.** Examination of the bottom of a tank which has been in use for six months, reveals only a thin layer of black earthy matter, the burnt-out ash of the solids of the sewage together with the mud and grit brought down by storm-water. So far as accumulation at the bottom is concerned, it would seem that a tank may be used for an indefinite time without requiring to be cleared. The larger part of the solids in the tank are found at the top, where a somewhat tenacious scum soon forms, consisting of the lighter solids in process of decomposition. The intensity of the action going on is evidenced by the large bubbles of gas, which everywhere break through the scum. Here is probably the chief seat of the bacteriological action, by which the solids are eventually thrown into solution. As soon as most of the organic matter in a solid substance is dissolved, the ash falls to the bottom, where decomposition continues its work. Presently a bubble of gas is formed, which buoys a fragment of ash and brings it again to the under side of the scum. The bubble soon becomes disengaged, and the ash falls again to the bottom. There is thus a constant interchange between the upper and lower layers of the tank, whereby its solid contents are brought under the most favourable conditions for rapid decomposition and solution. After a tank has been a short time at work, the scum increases in thickness very slowly. In one case, after thirteen months' work, the scum was only a few inches thick.

**The effluent from the tank** is comparatively clear and inoffensive, and not



liable to any subsequent fermentation, the work of decomposition being already done. In this state, there can be no reasonable objection to its discharge into tidal water. It is eminently fitted for utilization on land, containing, as it does, all the constituents of the sewage having any manurial value, in a form immediately available as food for plants; while its freedom from suspended matter removes the difficulty met with in irrigation with crude sewage. It is also in a fit state for filtration.

**The filtration of sewage or sewage-effluent** is not a mere straining action. If it were so, the filters would soon clog and become useless. Moreover, the effluent from the septic tank, being free from solids, is not susceptible of improvement by straining. The work to be done consists in the oxidation of the ammonia formed in the tank. This is by filtration converted into nitric acid, which at once combines with the bases present to form nitrates. The filtering area must be divided into at least two parts, each of which will be filled in turn while the other is emptying and at rest.

**An automatic alternating gear** for turning the sewage from one filter to the other forms part of the apparatus, and may be described as follows:—The supply of effluent to each filter, and the discharge of the clear water after filtration, are controlled by valves, all connected to one rocking shaft; the clear water from each filter passes into a bed of gravel underlying it, from which it is led by drains into a collecting-well; as the effluent fills the filter, the clear water rises in the collecting-well, and when the filter becomes full, a small quantity of clear water overflows from the collecting-well into a bucket carried by the shaft; the water thus thrown into the bucket bears it down the rocking shaft, and thereby actuates all the valves; the flow of effluent to the filter already full is stopped, and its discharge-valve opened, the effluent being turned on to the empty filter, whose discharge-valve is at the same time shut down. The water, rushing out from the filter last in use, draws down after it through the filtering material the charge of air required for dealing with the next dose of effluent. When the bucket which rocks the shaft sinks into its lower position, its contents are discharged through a counterbalance chamber, in which a part of the water remains to hold the valves in place until the other filter shall be full. The overflow from this second filter passes into another bucket, which was raised into position by the sinking of the first, and by means of which the valves are brought back into their original position. The first set of alternating gear installed was naturally regarded with the wholesome distrust engendered by sad experience of automatic devices, but six months' working has demonstrated its absolute reliability.

Plate XV. shows **the general arrangements of the septic tank and filter-beds**, with the ingenious arrangement whereby the filters are automatically changed so as to give each one a period of rest.

**The first working installation of the septic system** consisted of a small tank only, which dealt with the sewage of over thirty houses, as well as that of a large reformatory. It also received a considerable amount of storm-water. This tank was in use for thirteen months, during which it gave an uniformly clear effluent. At no time was any solid matter taken out of it, nor did it require cleaning at the end of that period. Since then a large installation has been put down, and is working splendidly.

A question naturally suggests itself with regard to **pathogenic organisms**. If, in order to purify our sewage, we provide conditions favourable to the growth of micro-organisms, will not the germs of disease be thereby retained alive or even increase in number? This question can be answered with a decided negative. Micro-organisms in general, and those of disease in particular, are peculiarly sensitive beings, requiring certain well-defined conditions as to food, temperature, and so on. During the passage of sewage through the tank and filters, any organisms contained in it are subjected to complete changes of environment. First we have the dark airless tank, then free exposure to light and air in the effluent-channels, and, lastly, the subjection to strong oxidizing agents in the depths of the filters. During each of these stages, any organisms originally present in the sewage are liable to be preyed on by others better adapted to the conditions in which they are placed. The experiments of the Massachusetts State Board of Health prove that the chances of microbes surviving the passage through a filter are infinitesimal.

**In the matter of cost**, the advantage of the septic system is not less marked than in that of efficiency. The capacity of tanks and filters required is not greater than with chemical processes, and the whole cost of machinery for preparing and mixing chemicals, and dealing with the sludge, and buildings for the accommodation of the machinery, &c., and for storing the sludge, is saved. The only additional item of cost with the septic tank system is the alternating gear, the valves themselves being common to both systems. The annual cost of working is practically *nil*.

Not the least advantage of the system is its power of **dealing temporarily with extraordinary volumes of sewage** far in excess of the normal capacity of the plant, a feature which renders it possible to abandon the risky expedient of discharging slightly-diluted sewage without treatment, whenever the volume of dry-weather flow is slightly exceeded.



With this system the difficulty often experienced in finding a suitable site for works of sewage-disposal is reduced to a minimum, for a septic apparatus can be placed in situations where a plant on any other system would be impracticable.

The analysis of the effluent from the filter of one of these works as taken by Dr. Rideal, was as follows:—

	Parts per 100,000.
Total solids, ... ..	76·8
Mineral matter, ... ..	57·1
Organic loss on ignition, ... ..	19·7
Chlorine, ... ..	7·28
Nitrogen as nitrates, ... ..	3·72
Nitrites, ... ..	strong
Free ammonia, ... ..	0·0124
Albuminoid ammonia, ... ..	0·044
Oxygen consumed in four hours at 80° F., ... ..	0·324
Total organic nitrogen, <sup>1</sup> ... ..	0·066

Dr. Rideal, in a paper which he read before the Sanitary Institute in December, 1896, on "The Purification of Sewage by Bacteria", stated, in connection with Mr. Cameron's septic process, that radical changes take place in the tanks, produced by the bacteria which are present in the raw sewage, and whose growth is favoured by the absence of light, air, and comparative absence of movement. He summarized the results of a series of experimental analyses, which he had carried out, as follows:—

- (1) A marked increase in the total solids in solution or fine suspension.
- (2) A reduction of about 33 per cent of the organic matter as measured by the oxygen consumed.
- (3) An increase of about 33 per cent in the free ammonia.
- (4) A reduction of about 54 per cent in the organic or albuminoid ammonia, or 50 per cent of the organic nitrogen.
- (5) A slight production of oxidized nitrogen, and a disappearance of a small amount of the total nitrogen."

These changes are effected by means of the bacteria, enzymes, or spontaneous chemical decomposition in the tank, and Dr. Rideal was of opinion that the septic tank effected as much purification as an average chemical precipitation process, or as slow upward filtration, and "that the solid fæces and other matter in suspension pass into solution in the septic tank".

<sup>1</sup> The Rivers Pollution Commissioners allow up to 0·3 organic nitrogen in an effluent passed into a river.

The effluent from the tank is arranged to flow in a thin stream over the edge of an "aëerator", or trough, into a receptacle communicating with the filters. At the aëerator, the effluent, which emerges free from dissolved oxygen, takes up atmospheric oxygen amounting to 0·56 c.c. per litre, or about 10 per cent of the quantity theoretically possible, before passing into the filter-beds. This preliminary aëration is a new departure, and worthy of every consideration, as it obviously is an important aid in supplying the necessary oxygen for the successful working of the filters.

The construction of the filter-beds and the material used in them do not call for any special remarks, as they have been constructed on well-known lines, and follow the conditions for successful working which have been established by the Massachusetts experiments, and more recently in this country by the London County Council, under Mr. Dibden's advice, at Crossness. In the latter case, the removal of 75 per cent of the oxidizable organic matters in solution in the chemically-treated London sewage was effected by filtering one million gallons of effluent through a coke-breeze filter of one acre per day; 50,000 gallons of sewage require 200 cubic yards per day, and this is approximately the filtering volume available at Exeter, excluding a reserve filter-bed of about one-quarter the above volume.

The effect of the filtration is to again considerably reduce the organic matter, as well as a large proportion of the free ammonia, and to produce a large amount of oxidized nitrogen in the form of nitrate. The following figures show the percentage of purification effected in the two series, calculated on the raw sewage and on the tank-effluents:—

- (1) Purification due to filters—  
Oxygen consumed, 73 per cent; albuminoid ammonia, 60 per cent.
- (2) Purification due to septic tank and filters—  
Oxygen consumed, 82 per cent; albuminoid ammonia, 77 per cent.

In other words, the process is almost identical in its results with that of the combined chemical treatment and filters as used at Crossness, the septic tank effecting 29 per cent purification as against the Rivers Pollution Commissioners' mean result of 28·4 per cent removal of organic carbon by all the best-known chemical methods, and the filters yielding 73 per cent purification on the tank-effluent as compared with 75 per cent purification obtained by Mr. Dibden in the same way on a chemically-treated effluent.

"A filtrate in an active bacterial state can, it is said, be discharged into a river or water-course without danger, and our present knowledge certainly warrants



some modification in the standard of purity of such discharges. The standard of 0.3 part per 100,000 of organic nitrogen some time insisted upon was never legalized, and has seldom been lived up to, even on well-managed sewage-farms, at all seasons of the year, and it is not adopted by the Thames Conservancy, which at present may be regarded as the most exacting authority in England. Adeney has suggested a simple standard which conforms to modern requirements, and which might with advantage be adopted by authorities. It is as follows:— The limit of impurity to be allowed to a given water should be such that, when a given volume of it is mixed with a given volume of fully aerated water, and the mixture kept in a bottle out of contact with air for a sufficient length of time, a decided oxidation of the ammonia originally present in the mixture into nitrous or nitric acid shall be indicated. If some such standard as this were generally adopted, it would tend to greater uniformity of results, and give a broader basis for judging as to the merits or demerits of any system of sewage-purification than we have at present. It would further show that it is possible to produce satisfactory effluents without the use of land, and would permit of the Local Government Board sanctioning schemes which would not only be more economical to execute, but be of a more satisfactory character than many sewage-works of the present time.” These are Mr. Cameron’s words.

In the author’s opinion, there is a **great future** before the “Septic” system, or some system embodying the same principles, such as the Bacterial or Aërobic methods of purification advocated by Col. Walter M. Ducat, (late) R.E., and Professor W. J. Dibdin, F.I.C., &c., which are practically on the same lines of allowing natural forces to act on the sewage by oxidation. The filter in each case is so constructed that the effluent from the sewage may be treated with as much air as possible.

Col. Ducat calls his filter the “**Aërated Bacterial Self-Acting Filter**”, and the following is taken from a circular letter issued by him on the subject:—

“By this method of disposal, the sewage, taken direct from the sewer without any preliminary treatment, is run on to a specially-prepared filter of an inexpensive construction, where, by the life-action of micro-organisms, the sludge or solid matter in the sewage is broken down and liquefied, in which condition much of the carbon, combining with oxygen, forms carbonic acid gas, which is dissipated inoffensively; and much of the nitrogen in the sewage combines with the hydrogen, forming ammonia. In this Aërated Filter, which is specially designed for the purpose, the process of purification by oxidation is fostered and furthered; the nitrogen of the ammonia and of the organic matter, in combination with the oxygen of the air, which this Aërated Filter alone can supply



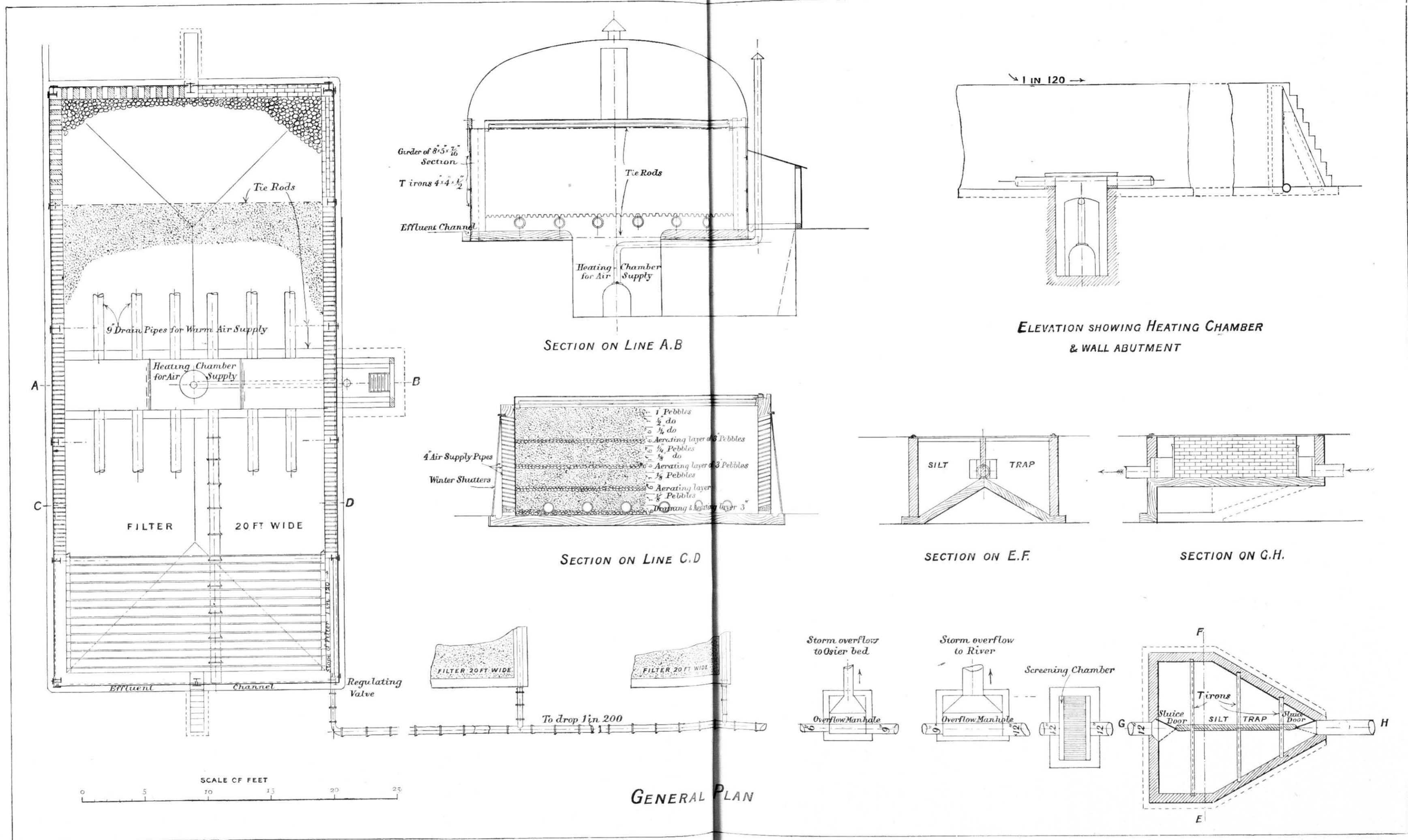

COL. DUCAT'S AËRATED BACTERIAL SEWAGE-FILTER.



automatically in sufficient quantity, forms nitric acid, which combines with the lime, soda, potash, or other suitable base in the sewage, forming nitrates or nitrites, which are entirely harmless, in the effluent.

"This elaborate process of the laboratory of nature is practically utilized and applied in the most scientific but at the same time the very simplest and cheapest manner possible. The sewage, without precipitation of sludge or treatment of any kind whatever, merely runs direct from the sewer on to the top of the filter and issues automatically from the base of the same,—an effluent bright, purer than that exacted by any Rivers Board, absolutely inodorous, and fit to go into any stream without causing offence or injury of any kind.

"As this method of sewage-treatment dispenses with the use of chemicals (which might be injurious to fish life), it will be found especially well adapted for use at the numerous seaside places where valuable oyster-beds or fishing-banks are endangered by the discharge of untreated sewage in their vicinity, and where the problem of the substitution of a harmless effluent is very difficult of solution.

"Sewage purification of a like high order cannot, by any other method, be effected so inexpensively as by this process: no chemicals are necessary, there is no sludge to deal with, the filters require a minimum of attention as there are no valves to open or adjust, the filtering material never wants washing or changing, and one man can superintend the purification of one million gallons of sewage a day, the only expense beyond the man's wages being a mere trifle for coke in winter to warm the air supplied to the microbes, and such small contingent charges as are incidental to all works of an engineering character.

"The facility with which a high degree of purification can be obtained, at a very trifling cost for fuel, during a long severe frost, when any ordinary filtration would be impossible, will, in many cases, make this filter especially valuable.

"The bacterial analysis of the effluent from the filter at Hendon (near London), where 250 gallons of raw sewage were being treated on each square yard of filter per day, equivalent to about one million gallons on an acre, has made it perfectly clear and certain that any required degree of purification can be obtained by this method of treatment, and rank sewage can, if necessary, be rendered as chemically pure as a high-class drinking-water. It is merely a question of adapting the height of the filter to the quality of the sewage to be treated and the purity of effluent desired; but that a very foul sewage can be rendered pure enough for all practical purposes by treatment in a filter eight feet high, is shown by the chemical analyses which have been made."<sup>1</sup>

<sup>1</sup>The reader must remember that these are Col. Ducat's remarks about his own invention, and must take them with the proverbial grain of salt. The statement that "the bacterial analysis of the effluent" at Hendon proves that



Tables XXXVI. and XXXVII., prepared by Dr. A. C. Houston, M.B., D.Sc., give the analyses of the crude sewage, and of the effluent from the tanks at Hendon, taken last year

Plate XVI. explains the construction of a "Ducat" filter. It will be seen that the sides of the filter are made with open drain-pipes, so placed that the outer end is above the inner, and thus the external air can blow in, but the sewage does not come out. The upper layers of the filter, where liquefaction takes place, are composed of coarser material, while the finer material is below. Various materials are suitable for this description of filter, as polarite, burnt ballast, gravel, coke, coke-breeze, and latterly coal, which is said to have considerable merit as a filtering medium.

The apparatus for warming the air supplied to the filter is placed in a chamber under the filter, as shown in the Plate.

Mr. W. J. Dibdin's process of filtration is much the same, but has not been patented, and consequently can be used by anyone without payment of royalty. Mr. Dibdin, at the Sanitary Congress in Leeds (1897), asked his hearers "not to call any particular system 'Dibdin's', because he had nothing to do with any system except in the way of scientific investigation, carried on in the interests of sanitation";<sup>1</sup> for want of another name, however, we must use the proscribed one, but with due apologies.

In order to complete the oxidation of nitrogenous animal matter, the ammonia—to use the words of Messrs. Dibdin and Thudichum—"has to be converted into nitric acid. This change, as is well known, is effected by the action of a micro-organism, or of a series of such; and it is thus established that a typical excretory substance can be entirely destroyed by the aid of fermentative or allied action of minute organisms without any adventitious assistance. That non-nitrogenized substances, such as starch, can, by the life-action of micro-organisms, be gradually oxidized and finally converted into carbonic acid and water, is, of course, a matter of common knowledge. The problem, therefore, resolves itself into the question of how this natural method of oxidation may be best controlled and expedited."

Messrs. Dibdin and Thudichum give their solution of the problem as follows: "In the recognition of the fact that all processes of sewage-purification must be made subservient to the requirements of the various micro-organisms, lies the

"rank sewage can . . . be rendered as *chemically* pure as a high-class drinking-water", is, to say the least, curious. Reference to Dr. Houston's remarks in Tables XXXVI. and XXXVII. shows that *he* cannot speak quite so highly of the purification; "the high-class drinking-water" of Col. Ducat is, according to Dr. Houston, only "practically" odourless, and "practically" free from cloudy appearance, and contains suspended matter, although "very little".

<sup>1</sup> *Journal of the Sanitary Institute*, Vol. XVIII., Part IV.

Ed.

TABLE XXXVI.  
CHEMICAL ANALYSIS OF THE "EFFLUENT" FROM COLONEL DUCAT'S AÉROBIC CULTIVATION FILTER.  
Results expressed as Parts per 100,000. To obtain grains per gallon, multiply by 0.7.

Date.	Total Solids.	Free Ammonia.	Albuminoid Ammonia.	Oxygen absorbed from Ferri-manganate in:—		Oxidized Nitrogen.	Remarks.
				1 hr. at 23° C.	5 hrs. at 23° C.		
Collected, 3/8/97.	136	0.95	0.08	0.56	0.64	2.28	The effluent was remarkably clear and transparent, and entirely free from objectionable odour. The cloudy appearance usually associated with Sewage-effluents was here practically absent. The suspended matter appeared to be very small in amount.
Examined, 4/8/97.							

TABLE XXXVII.  
COMPARISON BETWEEN THE CRUDE SEWAGE, AND THE EFFLUENT FROM COLONEL DUCAT'S AÉROBIC CULTIVATION FILTER.

Samples Collected, 3/8/97. Examined, 4/8/97.	Ammonia.			Oxygen absorbed from Ferri-manganate.		Remarks.
	Free Ammonia.	Albuminoid Ammonia.	Sum of the two Ammonias.	In 1 hr. at 23° C.	In 5 hrs. at 23° C.	
Crude Sewage, . . .	12.00	7.60	19.60	29.00	59.00	Very turbid, full of solid matters, having an extremely offensive odour. Practically odourless, clear and transparent, very little suspended matter visible.
Effluent, . . .	0.95	0.08	1.03	0.56	0.64	
Difference per cent, . . .	92	98.9	94.7	98	98.9	Difference per cent.



whole secret of success. All sterilizing or antiseptic agents must be strictly excluded; a condition of neutrality or slight alkalinity must be maintained; oxygen, anyhow in the final stages, must be freely supplied; the temperature must be kept above the freezing-point of water; and the amount of food must be proportioned to the powers of the organisms."

There are two stages in the purification of sewage—one in which the organisms break down and liquefy solid organic matter, and the second, in which the organisms deal with the sewage when in solution (the effluent). The organisms may again be divided into two classes, (*a*) those which do their work in the presence of air, and (*b*) those that thrive in its absence. The latter are those which are at work under the "Septic" Tank system already described, and the others are those which are doing their work in the thoroughly-aërated filter-beds at Sutton near London, where simple filter-beds, thoroughly aërated, are said to be successfully purifying a sewage-effluent.

Mr. Dibdin arrived at these conclusions after a series of exhaustive experiments on London sewage, carried out by him under the direction of the London County Council at the Metropolitan Northern Outfall Works. In March, 1895, Mr. Dibdin presented a voluminous report on the subject, which is given in *The Surveyor*, Vol. VIII., No. 198, and contains a vast amount of most useful information upon this important and disputable subject. For further information, the reader may consult the book on the subject recently published by Mr. Dibdin.

## CHAPTER VIII.

### INTERCEPTION OR DRY SYSTEMS.

Having thus far treated of methods of dealing with "water-carried" sewage, it will be necessary to turn to the question of what is known as "Interception", or the intercepting of the faecal matter and waste products of our dwellings, &c., without allowing them to enter the sewers. It must not, however, be lost sight of that, in every large community, sewers will still be a necessity, even if an "interception" system is introduced, for, as the Rivers Pollution Commission of 1868 reported (*First Report*, vol. i. 1870, page 30), "the retention of the solid excrements in middens is not . . . attended with any considerable diminution in the strength of the sewage, although the volume, even in manufacturing towns, is somewhat reduced". In other words, an interception system

will not do away with the necessity for sewers to carry off the slop water, the washings of yards, and also of the public streets, percolations of filth from cess-pools, dung-pits, and the like, and also manufacturers' wastes, public urinals, &c.

The crowding of our populations into cities, and the altered conditions of our lives, have made it absolutely necessary that the cleanly and convenient method of carrying away our sewage-matters by water should take the place of the filthy method of storing such matters in or near our habitations. The difficulty of removing and ultimately disposing of this filth is a serious objection against all the so-called "interception" systems. These systems may be summarized as follows:—

- (1) Various forms of middens.
- (2) Box, tub, or pail closets.
- (3) Dry-earth, ash, or charcoal closets.

The primitive "fosse", ditch, or simple hole dug into the ground to receive the human faeces, gradually evolved into the privy, no doubt first by the introduction of some kind of rough seat, and then it was built round and roofed for privacy (hence "privy") and for shelter. Before this advance was made, it is probable that the fosse or hole was lined, or "steined" as it is technically called, with a rough lining of stones or bricks. Then a more modern seat was added, and the privy or midden was complete.

Fortunately the old-fashioned midden-closet is now almost a thing of the past in most of the larger towns in this country, though it is still to be found in rural districts and attached to isolated houses. Mr. Redgrave, in a paper which he read before the Institution of Civil Engineers in 1876,<sup>1</sup> says:

"It can only be spoken of in the language of Mr. Radcliffe (*vide Rivers Pollution Commission*, 1868, *First Report*, vol. i. 1870, page 30) as the standard of all that is utterly wrong, constructed as it is of porous materials, and permitting free soakage of filth into the surrounding soil, capable of containing the entire dejections from a house, or from a block of houses, for months and even years; uncovered and open to the rain, the wind and the sun, difficult of access for cleansing purposes, and unventilated and undrained." And again, in the *First Report* of the Rivers Pollution Commission, speaking of Manchester at pages 23 and 24, the commissioners say:—"In spite of district inspection under an energetic and experienced chief, in spite of police assistance, and notwithstanding that the penny post enables every householder so easily to give notice to the scavenger, privies and ashpits are continually to be seen full to over-

<sup>1</sup>Vide *Minutes of Proceedings of the Institution of Civil Engineers*, vol. xlv. page 130.



flowing and as filthy as can be. . . . These middens are cleaned out whenever notice is given that they need it, probably once half-yearly on an average, by a staff of night-men with their attendant carts. Occasionally twenty or thirty middens are thus cleaned out in succession, the contents being wheeled along the whole length of the row, making the air offensive for several nights together, and creating a nuisance none the less injurious because, the work being done when the people are asleep, the filthy smell is not perceived."

Later sanitation insists that where **these abominations** exist, the pit shall be lined imperviously—to prevent soakage into the surrounding soil—with hard

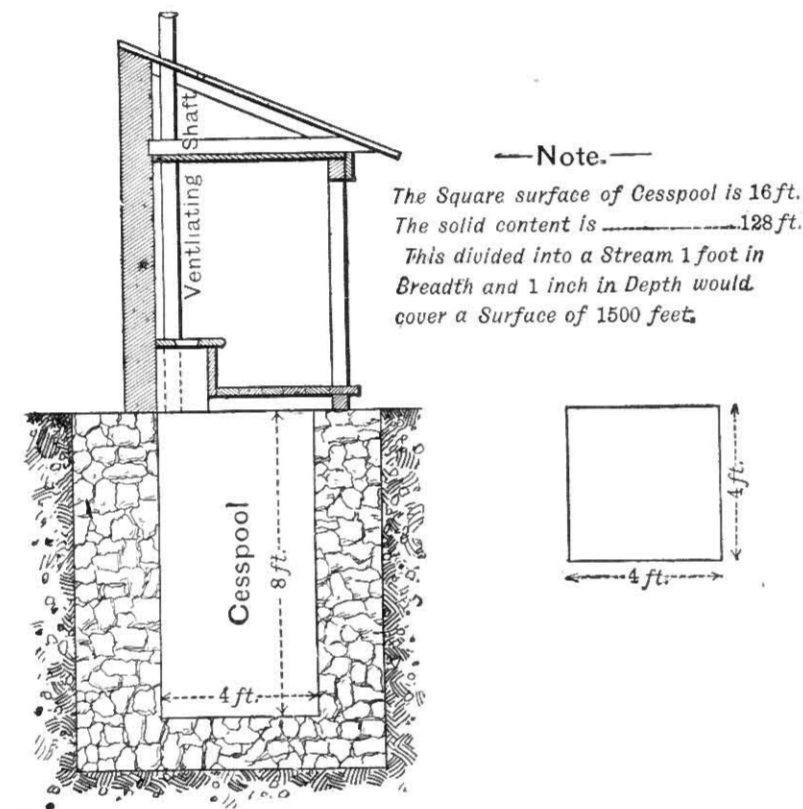

Fig. 430.—Section of insanitary Privy and Cesspool.

bricks or stones, set in cement mortar, and rendered or covered with cement mortar or other hard impervious material. Sanitation also insists that the midden shall be so covered and ventilated that the effluvium may pass away harmlessly into the air, and not solely through the seat into the privy building. The pit should also if possible be drained, so as to carry off the moisture, and the shape of the pit should be so arranged that its contents can be easily removed, and with as little nuisance as possible. A still more modern improvement is the provision of some simple arrangement whereby the contents of the pit may be deodorized by the addition of dry earth, ashes, or some such cheap absorbent and deodorant. It is almost unnecessary to state that a privy of this description (see fig. 430) is thoroughly insanitary, when it is situated near any dwelling-house.

It will be seen on reference to the foregoing figure how difficult it would be to cleanse such a privy or midden, but the following illustration shows an example of an **improved midden-privy** as constructed at Nottingham. The bottom of the receptacle is concave, in order that everything may gravitate towards the centre of the pit, and the brickwork is well rendered in cement on the inside to make the pit impervious. There is also a special opening through which ashes or other deodorant may be thrown on to the contents of the pit,

and a ventilating shaft is also shown to be carried up, so as to give thorough and safe ventilation. The riser of the seat is constructed in brickwork, and the floor is paved.

The Nottingham type of midden is, of course, free from many of the ob-

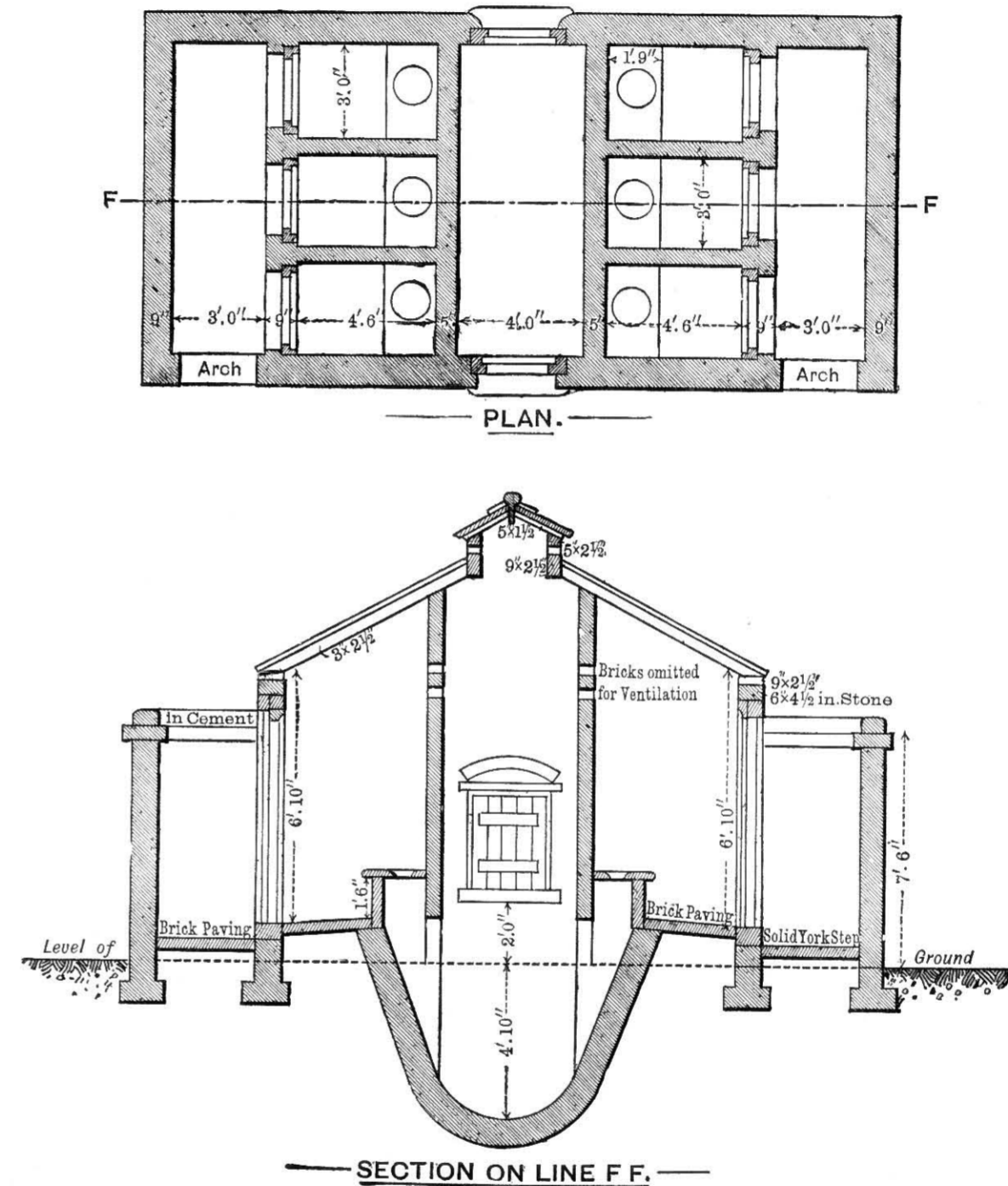

Fig. 431.—Plan and Section of Midden-closet in use at Nottingham.

jections raised against the old-fashioned midden-privy; but a better example is that of **the Burnley midden-closet** (fig. 432), the receptacle of which has the floor constructed of glazed stoneware, with an overflow-pipe connected with the sewer, and is of such small dimensions that its contents can be easily and readily removed.



A further improvement is shown in the midden-closet as formerly constructed

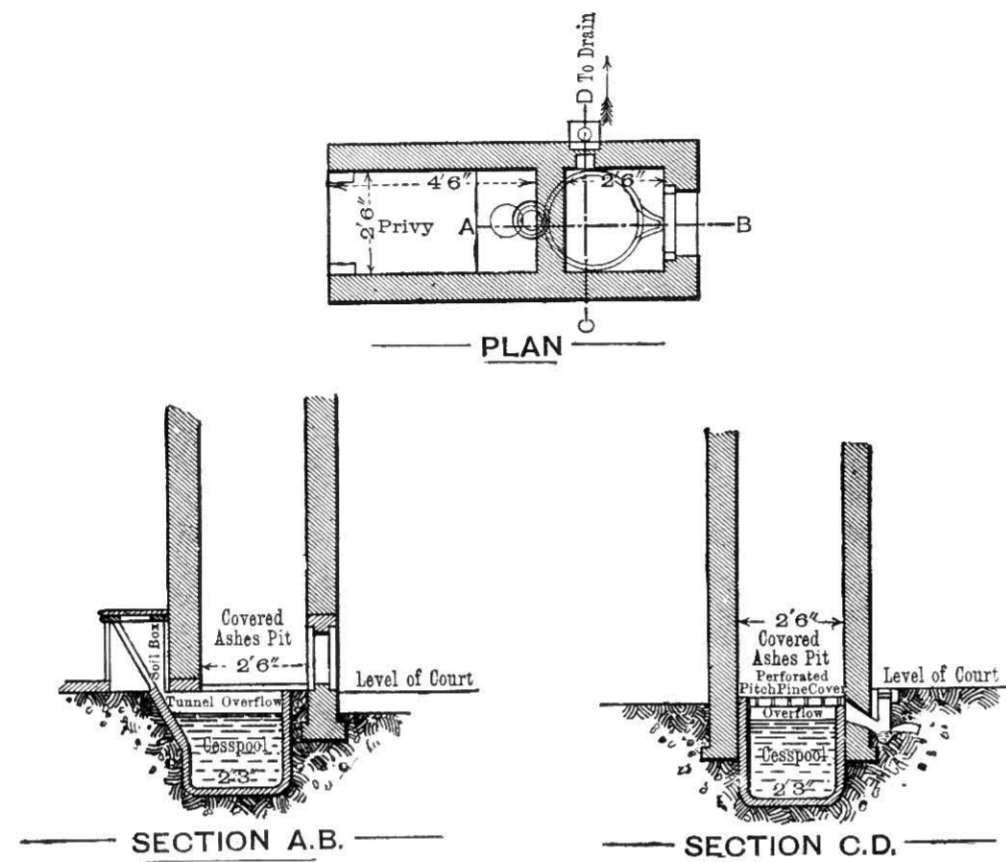

Fig. 432.—Plan and Sections of Midden-closet in use in Burnley.

at Stamford (fig. 433), where the seat is hinged, so that it can be thrown up and the house-ashes emptied on to the contents, as these assist in deodorizing the

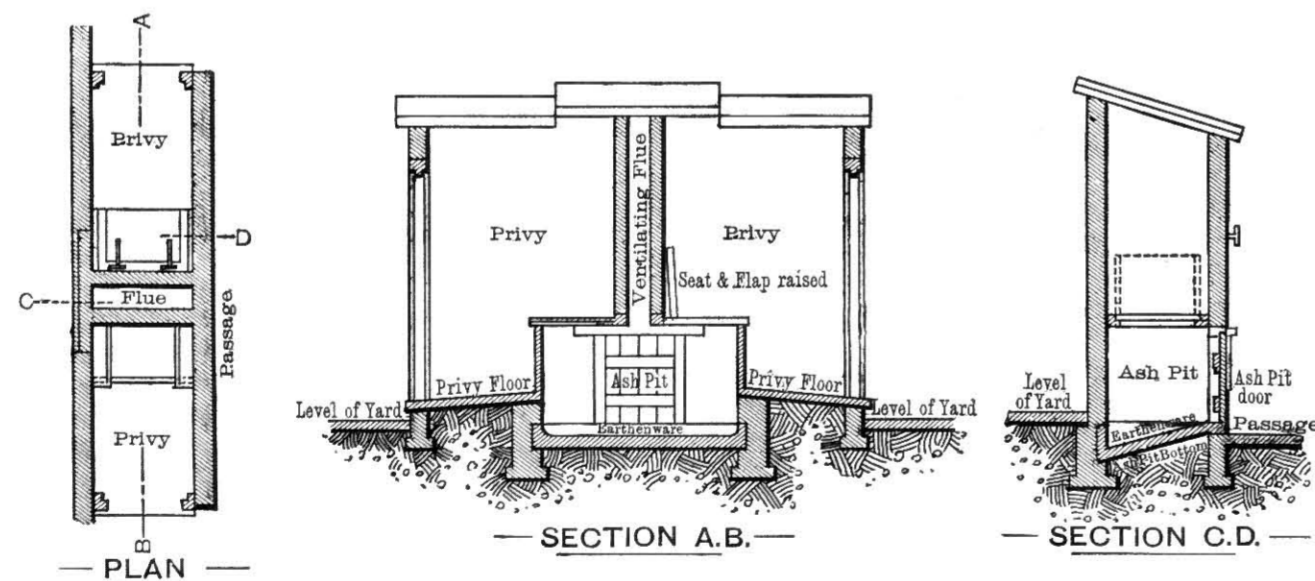

Fig. 433.—Plan and Sections of Midden-closet in use in Stamford.

fæcal and other putrescent matters. The midden is also very shallow, necessitating frequent cleansing.

The final type of midden-privy which will be given, is that which formerly

used to be constructed at Manchester, and is known as the **Bevel Midden**, from the shape given to the side of the midden to facilitate cleansing and emptying. The shape of the midden is undoubtedly an improvement, but it is so large, that the removal of the contents cannot fail to be arduous and unpleasant.

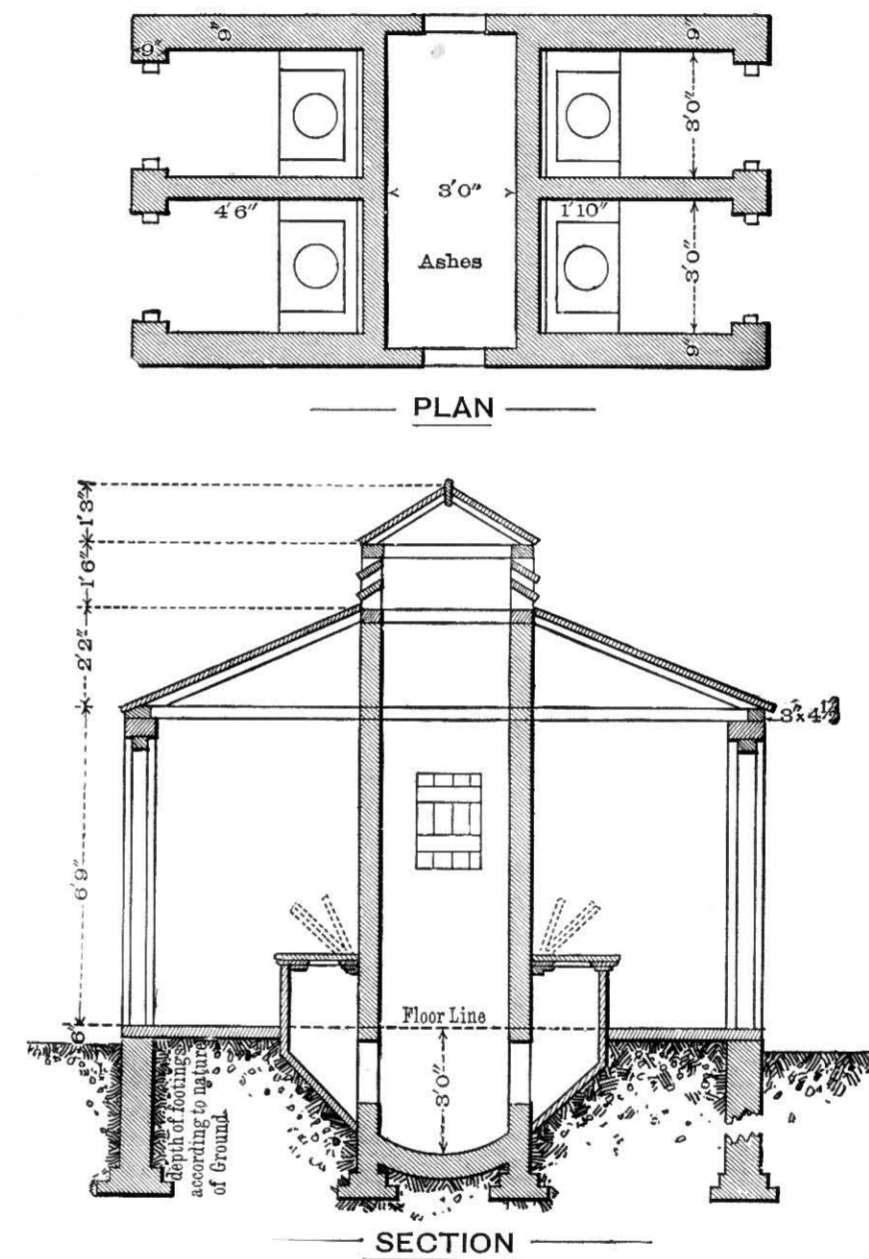
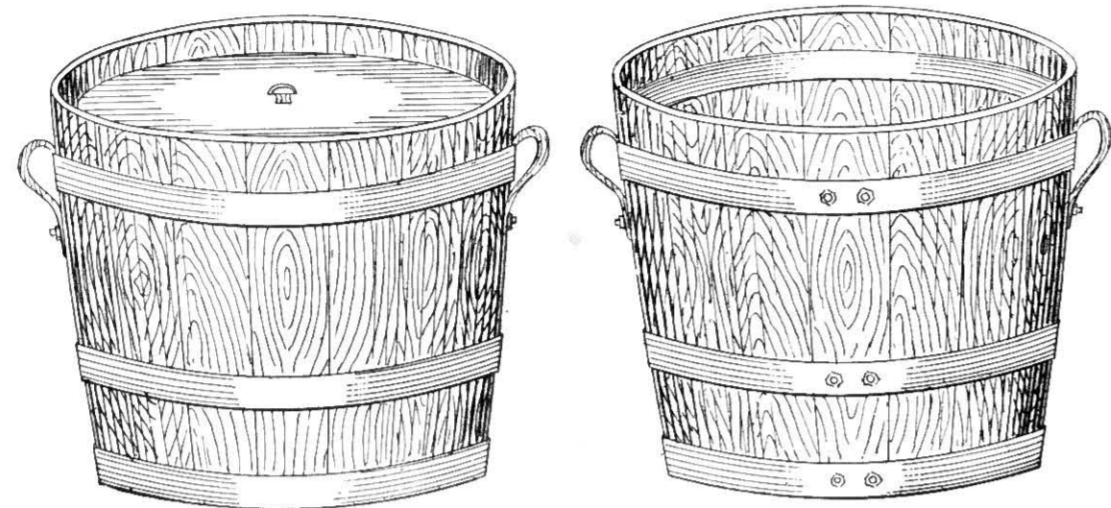

Fig. 434.—Plan and Sections of Midden-closet formerly used in Manchester.

Thus, the midden or privy-pit became smaller and smaller, and its transition into the **pail or receptacle closet** was an easy step. This is now known as the "Tub", "Pan", or "Pail" Closet, and is largely used in one form or the other in many manufacturing centres. It is undoubtedly a great improvement on midden-closets, as, on account of the small size of the receptacle, the fæces are more frequently removed, and the labour and nuisance of such removal are greatly reduced. Each closet must have its own receptacle, and the front of



the seat must be arranged to take out, so that the pail can be easily removed.



Full Pail with Lid on, to return to works.

Empty Pail, ready for use.

Fig. 435.—Rochdale Excrement-pail and Cover.

The pail and cover used at Rochdale are shown in fig. 435, the pail being of wood, while the Birmingham pail and cover (fig. 436) are of galvanized iron.

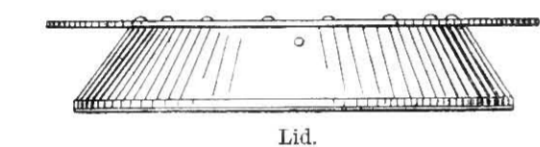

Lid.

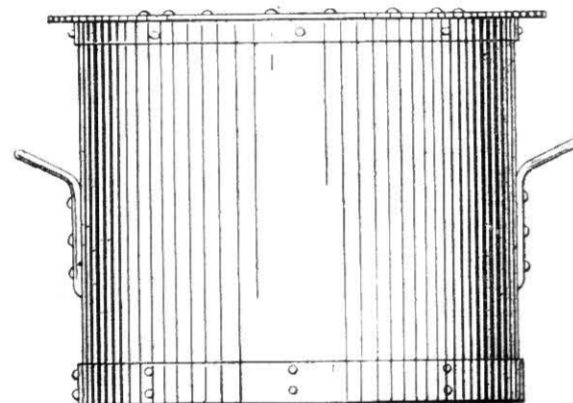

Pail.

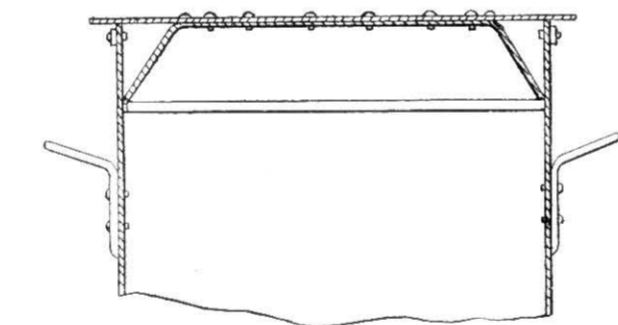

Section showing the Lid in Position.

Fig. 436.—Birmingham Excrement-pail and Cover.

Manchester was one of the first cities to alter privies into pail-closets, and to add the ashes to the faecal matter as shown in fig. 437. It will be observed that the building in this case is some-

what similar to a common privy, but that underneath the seat is an iron pail, circular in form, which contains the faeces, &c., and the garbage and other matters which the woman is seen to be emptying into a series of screens or sifters, arranged in a shaft or long box outside the wall of the privy. The finer ashes are sifted out and fall into the pail under the seat, whilst the larger cinders fall down into the box below, from which they can be easily removed by means of a door, and re-burned or used in other ways. There are several modifications of this process, by which the fine ash is added to the contents of the pail, all being undoubtedly a great advance upon the old privy or midden.

Not long after the introduction of the pail-system into this country, Mr.



Fig. 437.—View of Manchester Privy with Cinder-sifter.

Goux of Rochdale introduced an absorbent pail, in which the ashes are applied to the pail before it is sent out, the sides and bottom being lined with ashes

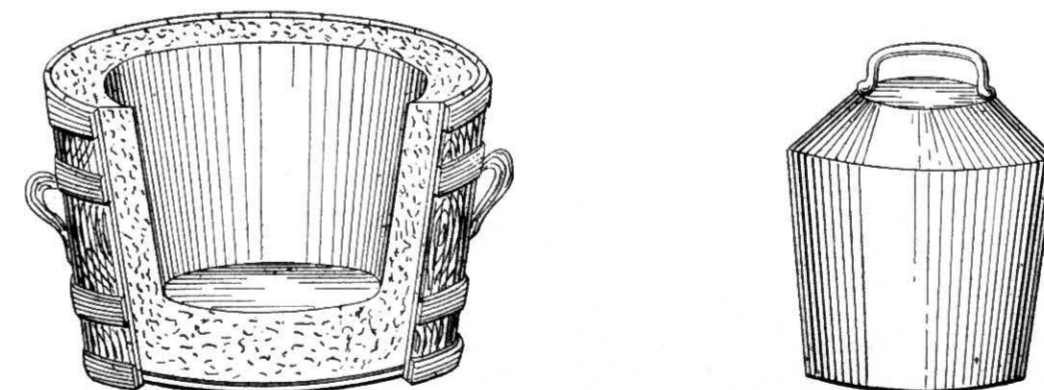

Fig. 438.—“Goux” Excrement-pail and Mould.

pressed into shape by means of a mould. Fig. 438 illustrates this form of pail, and the mould used in forming the inside of it. In addition to ashes, the



absorbing material contains dry street-sweepings and factory-waste, to which is added sulphate of lime; the mixture is pressed down, and when the pail is placed in the closet, the mould is withdrawn. It is claimed that the absorbent material takes up the urine and other moisture, prevents decomposition, and facilitates the conversion of the excreta into a portable manure. The opponents of this special pail say that there is nothing in these claims, and that the lining merely adds to the weight of the pail. There can be no doubt, however, that the attempt, whether successful or not, merits approbation.

The collection of the pails is in most cases effected by means of specially-constructed closed wagons, which are sent round, generally at night, accompanied by men, who collect the full pails and substitute empty ones which have been

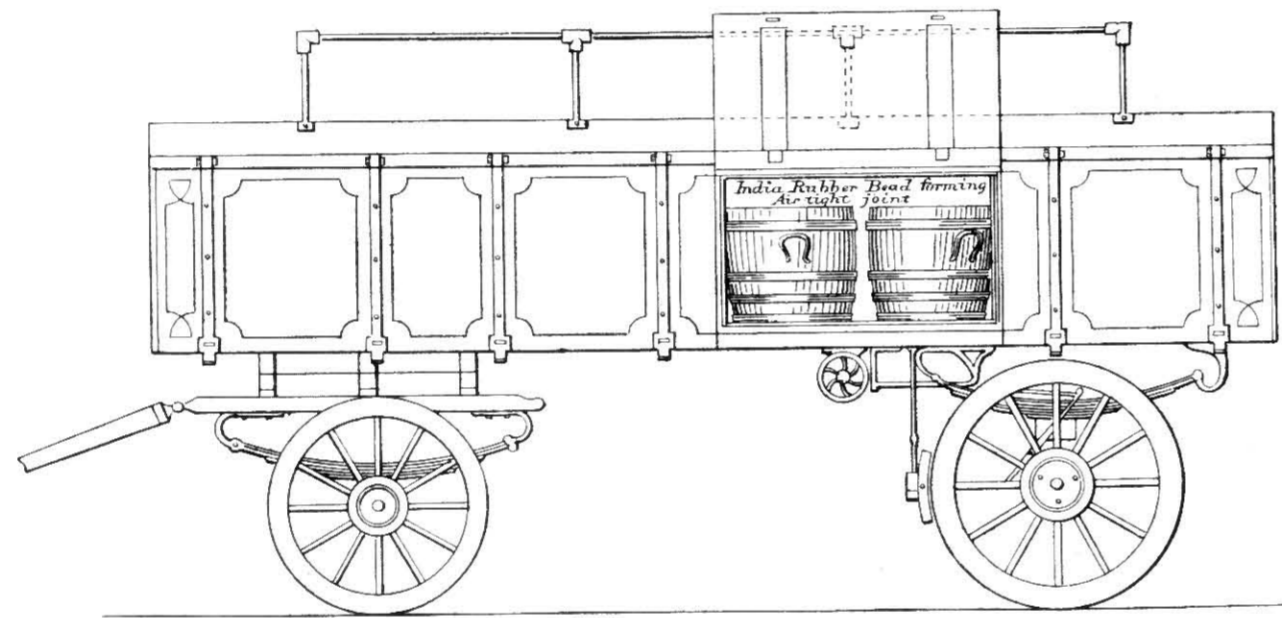

Fig. 439.—Rochdale Night-soil Van.

previously cleansed and disinfected at the various depots. The wagons for this purpose are generally after the pattern shown in fig. 439. The full pails are placed in the wagon, which is then taken to the depot.

The contents of the pails are variously treated. In some cases they are mixed with a sufficient quantity of dry ashes (house-refuse) to absorb the liquid, and are then placed in a stirring-mill, where offal or other animal refuse is added. Whilst this mixture is passing through the mill, about 5 per cent of gypsum (sulphate of lime) is added to fix the ammonia. The mixture thus prepared consists approximately of about 20 per cent of excreta and urine, 20 per cent of offal, &c., 5 per cent of gypsum or sulphate of lime, and 55 per cent of fine ashes. This is then passed over a fine sieve or screen, which takes out all the coarse parts, and the residuum is put into bags and sold as manure, which is said to be worth about 15 shillings a ton.

The following is a description of the method at one time followed at Manchester, and which, with some modifications, is still employed. The pails having been emptied over a grating which held back the solid matter, the liquid contents were evaporated to one-tenth of the original bulk, or even less, in an apparatus called the "concretor", which consisted of a revolving cylinder, 8 feet long and 4 feet 6 inches in diameter, having its ends partially closed by annular rings, and fitted inside with scroll-like plates of thin metal. The liquid was admitted into this cylinder, and as it revolved, these scroll-like surfaces became wetted; the evaporation was effected by passing heated gases through the cylinder. As these came into contact with the wetted surfaces of the metal scrolls, rapid surface-evaporation took place, the temperature of the liquid, however, remaining low,—so low that, though it was discharged from the cylinder at nearly the consistency of treacle, it was rarely, if ever, at so high a temperature as 130° F.

The hot gases, used for effecting evaporation in the concretor, resulted from the combustion of refuse-material, usually consisting of a small portion of cinders and a large quantity of ashes, together with animal, vegetable, and mineral refuse, forming a compound containing too little manure to be valuable, but quite enough to be objectionable. This material, so difficult to be disposed of satisfactorily, and often saturated with water, was shot into a furnace of special construction termed the "Destructor", so arranged that the material had to traverse a considerable distance within it, exposed to the products of combustion on their way to the chimney, and to the heat radiated from the roof and sides, before it reached the fire-grate. It was thus effectually dried before any attempt was made to burn it. The products of combustion from this furnace were passed through the "concretor" cylinder to effect the evaporation required there on their way to the chimney. The gases, resulting from the combustion of the materials above described, usually contained a small quantity of sulphurous acid, which was sufficient to slightly acidify the liquid in the concretor. If they did not contain it naturally, a little sulphur must be added for the purpose of producing the acid.

The low temperature was not sufficient to cause any appreciable loss of nitrogen, or evolution of ammonia, from the slightly-acidified liquid undergoing concentration. The concentrated material was therefore a fairly strong manure. A random sample of it had been reported upon by Messrs. Burghardt, Grimshaw, & Co., Dalton Laboratory, Manchester, as "undoubtedly a very strong manure, owing especially to the high amount of available nitrogen which decomposes in the ground, and may be expressed as 9.88 per cent of ammonia".

Refuse fuel, such as that used in the "destructor", produced a large amount



of clinker, which, when ground up with a little lime, formed a strong mortar. The process of concentration was not a source of nuisance. "Even the most offensive putrid urine speedily lost almost the whole of its disagreeable odour when undergoing concentration, doubtless owing to the action of the sulphurous acid upon it."

The pails themselves had a little charcoal put into them to deodorize their contents, and render them innocuous, and charcoal might in like manner be added to the concentrated liquid to prevent it from becoming offensive. This charcoal was also manufactured from refuse material; it was composed of carbonized street-sweepings, market-refuse, &c., and needed special apparatus to carbonize it, since the low value did not permit of costly handling, while it was bulky and difficult to separate. The heating was effected by a small furnace fed with cinders and other refuse fuel, while the carbonizing kiln consisted of a rectangular chamber of considerable height, into the top of which the material to be operated upon was thrown, and through which it gradually descended as its bulk diminished and the material below was removed. Finally, when sufficiently carbonized, it was withdrawn through a slide in the bottom of the chamber. The fire in the furnace was kept thick, and the supply of air to it small, so as to prevent the admission of sufficient oxygen for perfect combustion; thus the products of combustion from it could only heat, and not burn, the materials with which they came into contact, and they might therefore safely be brought into direct contact with the materials to be carbonized. These products of combustion entered the kiln, or carbonizing chamber, near the bottom, and were guided around it by iron plates which touched the wall at their top edges, but sloped so that their bottom edges were some distance from it. These ran around the chamber in a spiral form, and kept open a passage, along which the products of combustion could always find a way to the chimney, while, as they were open at the bottom, the gases could come into direct contact with the materials in the kilns. The plates becoming heated also helped to dry and carbonize the materials. Finally, the products of combustion were led away to the chimney through a flue near the top of the chamber.

By the above methods, almost the whole of the material which came into the yard was effectually dealt with, and turned into a product of much less bulk, capable of being applied to some useful purpose either as a manure, a deodorant and disinfectant, or as mortar, while there was no need for costly chemicals or extraneous fuel. At the same time, the whole of the matter was rendered harmless, and incapable of spreading infection or disease, for it was purified by fire.

Another apparatus for the disposal of the contents of pails consists of a **steam-jacketed cylinder** about 13 feet long and 4 feet in diameter, fixed on a hollow revolving shaft, with hollow agitators into which steam is admitted at 60 lbs. pressure. The contents of the pails, mixed with about 1.25 per cent of sulphuric acid, are placed in the cylinder, and the agitators, filled with steam, slowly revolve. About  $2\frac{1}{2}$  tons of pail-contents, holding at least 83 per cent of water, are reduced in  $3\frac{1}{2}$  hours to about 4 cwts. of a lumpy dark-red loam, containing only about 5 per cent of water. This is allowed to cool, and then riddled into a powder, which is sold as manure, in some cases being of a value of £6 or £7 per ton. Its chemical analysis is as follows:—

Insoluble silica, ... ..	=	3.216	per cent.
Lime, ... ..	=	1.310	"
Oxide of iron and alumina, ... ..	=	0.607	"
Sulphuric acid, ... ..	=	1.885	"
Phosphoric acid, ... ..	=	3.102	"
Sulphate of potash, ... ..	=	5.586	"
Chloride of magnesium, ... ..	=	1.910	"
Chloride of sodium, ... ..	=	5.120	"
Sulphate of ammonia, ... ..	=	22.191	"
Organic matter, ... ..	=	55.073	"
Total, ... ..	=	100.000	

With regard to the dry-earth or pail systems, there can but be one opinion as to their unsuitability for modern civilization, and we must agree with the following **conclusions of the committee appointed by the Local Government Board** in 1875 to inquire into the various methods of sewage-disposal:—"That the retention . . . of refuse and excreta . . . in cesspools . . . or other places in the midst of towns, must be utterly condemned, and that none of the (so-called) dry-earth or pail systems or improved privies can be approved other than as palliatives for cesspit middens".

The committee appointed by the Society of Arts in 1876 to inquire into various subjects connected with the health of towns, came to the following resolutions:—

"(1) That the pail-system, under proper regulations for early and frequent removal, is greatly superior to all privies, cesspools, ashpits, and middens, and possesses manifold advantages in regard to health and cleanliness, whilst its results in economy and facility of utilization often compare favourably with those of water-carried sewage.

"(2) That hitherto no mode of utilizing the excreta has been brought into operation which repays the cost of collection.



“(3) That the almost universal practice of mixing ashes with the pail-products, though it applies there as a convenient absorbent and possibly to some extent as a deodorant, is injurious to the value of the excreta as a manure.

“(4) That for use within the house no system has been found in practice to take the place of the water-closet.”

There can be no doubt, however, that for certain **isolated houses** some other methods than those of water-carried sewage commend themselves to our notice, and the next chapter will consequently be devoted to this problem.

## CHAPTER IX.

### SEWAGE-DISPOSAL FROM HOUSES NOT CONNECTED WITH ANY SEWERAGE-SYSTEM.

Having thus far dealt with the general question of the disposal of sewage, it is necessary to say a few words upon that very difficult problem of **the disposal of sewage from isolated houses**, which have not the advantage of being connected with any general system of sewerage. A number of the previous remarks will apply in considering this question, but, of course, unless the isolated house is a large establishment, such as an asylum, hospital, gaol, hotel, school, large mansion, or something of the kind, it would be an expensive if not an altogether unwarrantable proceeding to adopt a chemical precipitation or other process for dealing with the sewage; nor might it be possible, on the other hand, to find sufficient land to take the sewage on the irrigation or filtration system, although in some cases, even where there is but little available land, this latter method might be advantageously adopted, and the remarks in the preceding pages on these systems are worthy of attention in connection with this question. Let us, however, deal with the problem of the disposal of the sewage from an isolated cottage or small residence.

Hitherto the methods mostly adopted in connection with such houses have been either privy-middens or cesspools, as being the most convenient and least expensive methods for getting rid of the sewage-matters. With regard to the former method, all the necessary remarks have been made in the chapter dealing with “Interception” or dry systems, so that the cesspool only remains to be considered.

**The cesspool** has been found—and is still found—to be the most convenient method for disposing of the sewage from isolated establishments, but it is almost

unnecessary to state that such an arrangement is barbarous and insanitary, especially where, as in the majority of cases, the cesspool is badly situated and wretchedly constructed. Other books have dealt at length with the evils arising from ill designed and badly-situated cesspools, especially that delightful book on *Dangers to Health*, by T. Pridgin Teale, M.A., so that it is unnecessary to say more upon the subject, but rather to point out what considerations are necessary to mitigate as much as possible this, at present, requisite adjunct to many houses; and it will be the object of these pages to endeavour to point out some of the more modern methods for effecting this purpose.

**The choice of position** must be guided by the available land, the position of the house, the gradient of the land, and above all by the “dip” of the subsoil-

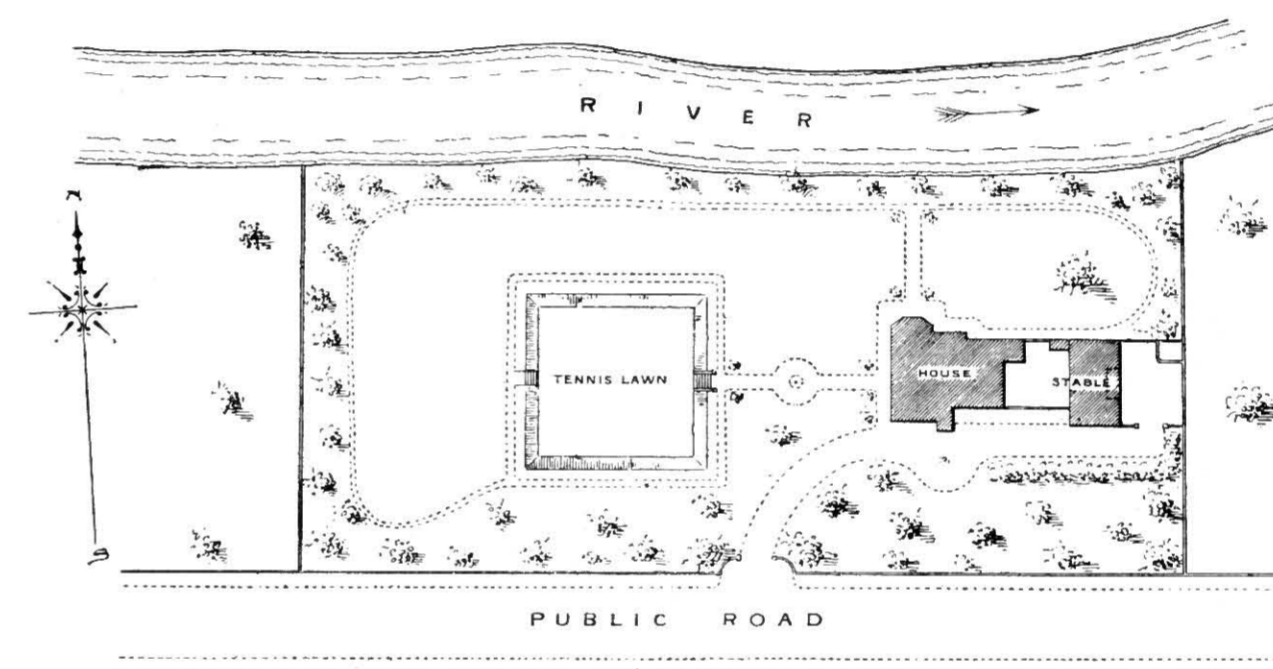

Fig. 440.—Plan of Country-house and Grounds.

strata and the position of the well or water-supply. One of the questions often given to the candidates at the examinations held by the Sanitary Institute for pass certificates for fitness as a Sanitary Inspector, is as follows:—A sketch, similar to that which is here given, is laid before the candidate, and he is asked, “Where would you put the well, and where the cesspool in this case, where there is no sewage-system and no water-supply?” In giving the answer, the candidate must consider the question of the fall of the ground, which is obviously from the road towards the river, and the flow of the river, which is in an easterly direction. The correct answer is purposely not given, but is left to the ingenuity of the readers of these pages.

Having settled the position, it is necessary to consider **the size of the cesspool**. This will, of course, be governed by the daily quantity of the flow of the sewage,



and the interval of time to be allowed between each cleansing of the cesspool. The quantity of the daily flow depends upon the number of persons inhabiting the house, and the water-supply. That great sanitarian, Dr. Edmund A. Parkes, in his *Manual of Practical Hygiene*, states that "in poor families who draw water from wells, I have found the amount to vary from 2 to 4 gallons per head, but then there was certainly not perfect cleanliness"; and further on he states, after quoting various authorities, "I believe we may safely estimate that for personal and domestic use, without baths, 12 gallons per head daily should be given as an usual minimum supply, and with baths and perfect cleanliness 16 gallons should be used. This makes no allowance for water-closets or for unavoidable waste."

It is probable that these observations of Dr. Parkes hold good to the present day, so that, as  $6\frac{1}{4}$  gallons of sewage equal a cubic foot, the dimensions of the cesspool can be easily calculated, when we know the exact amount of daily flow from a given number of persons, and have decided how often the cesspool should be emptied. If any part of the rainfall enters the drains, the calculations will be somewhat more complicated.<sup>1</sup> Authorities on this subject state that a cesspool should be emptied at least once a week, but it is much to be feared that, owing to the nuisance and expense of this operation, much longer intervals are allowed to elapse between the cleansings, and this is specially the case where there is an overflow from the cesspool into an adjoining ditch or stream, or where, as in the majority of cases, the cesspool is stoned with open brick or stonework so as to allow the liquid contents to soak into and pollute the surrounding soil, the solid matter remaining behind in a terribly decomposing condition.

Having then settled the dimensions, it is necessary to design **the shape of the cesspool**. It is found geometrically that the largest area is obtained, with a given amount of material, by a circular chamber, and in addition to this such a shape has considerable resisting power, and, if properly designed, is more easily cleansed. Thus, for a simple cesspool, the design shown in fig. 441 meets most of the requirements.

**The construction of the cesspool** is a matter of great importance. In order to make the cesspool water-tight, it is a good plan to excavate the ground sufficiently wide that the cesspool can be surrounded with at least 6 inches of well-puddled clay. It is almost unnecessary to say that it should be built of good hard bricks (better lined throughout with Staffordshire blue bricks), set in Portland-cement mortar. It should be covered with a hermetically-closed door for access for cleansing, and be well ventilated.

<sup>1</sup> For particulars of rainfall, see § III., "Water-Supply".

**The drain from the house** should enter above the highest point to which the sewage can rise in the cesspool, and be trapped and ventilated exactly in the same way as if the cesspool was a public sewer (see fig. 441).

If there is no available land or other safe method for dealing with **the liquid overflow from the cesspool**, no overflow should be allowed, and the cesspool must be oftener cleansed. If, however, there is sufficient land, the overflow may be directed over alternate filter-beds of either gravel, suitable soil, or coke-breeze, in the manner already described under the head of "Filtration".

Where no overflow can be arranged, the cesspool would be better if constructed in duplicate, as shown in fig. 442.

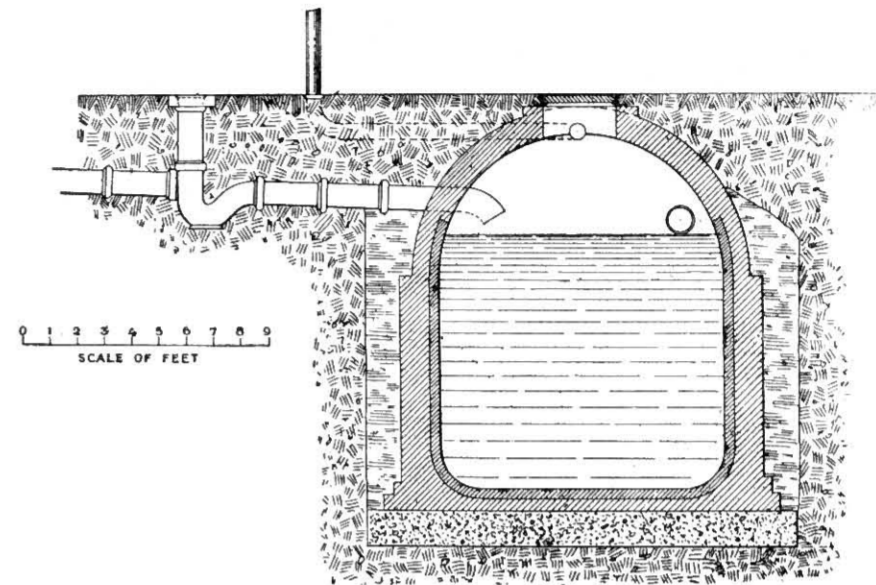

Fig. 441.—Section of Circular Cesspool.

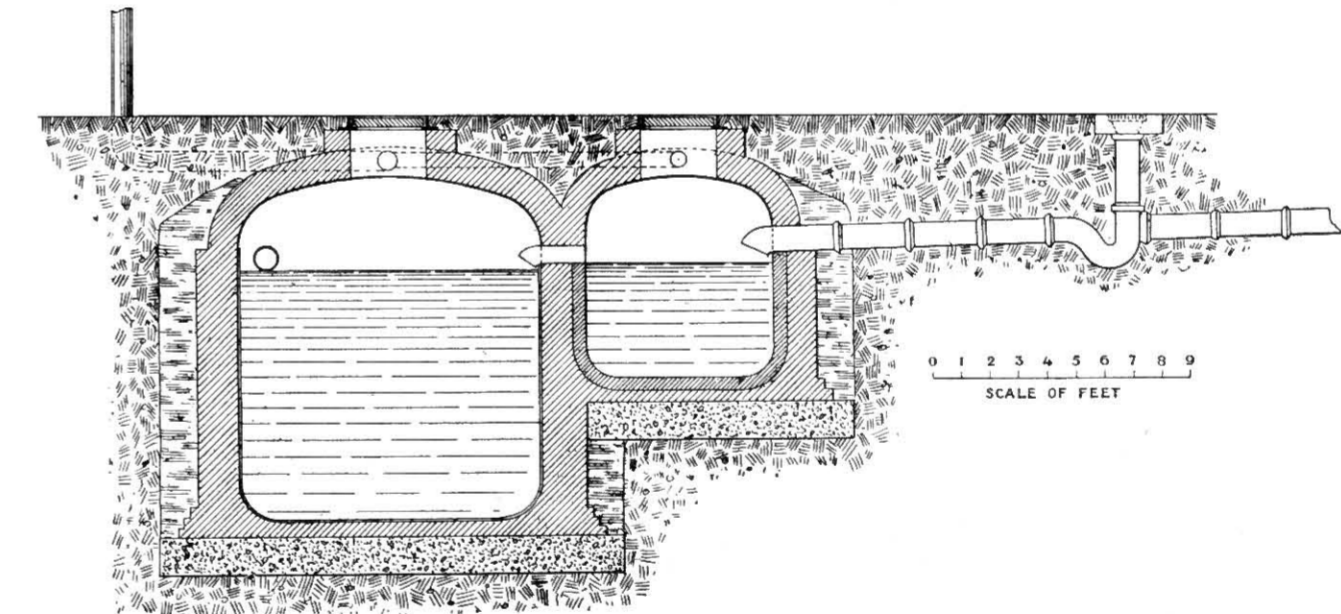

Fig. 442.—Section of Double Cesspool.

**The cleansing of cesspools** is always a disgusting and troublesome process, and is generally effected at night. It is usually done by hand labour, the contents being shovelled or pumped into carts or wagons, either open or covered, and carried off to be deposited on land or into pits, or otherwise dealt with. This method of emptying cesspits is essentially crude and unscientific. In France and other continental countries, for many years past, they have been emptied by pneumatic force. The vehicle consists of an iron tank on wheels,



from which the air is abstracted by a pump; a hose attached to the vehicle is inserted into the cesspool, a stop-cock on the hose is opened, and the tank is filled by the pressure of the atmosphere without causing the slightest nuisance. Messrs. Merryweather, the well-known makers of fire-engines and fire-appliances, have designed and constructed an excellent tank of this description, which is shown in fig. 443. The apparatus, as will be seen, consists of a tank or

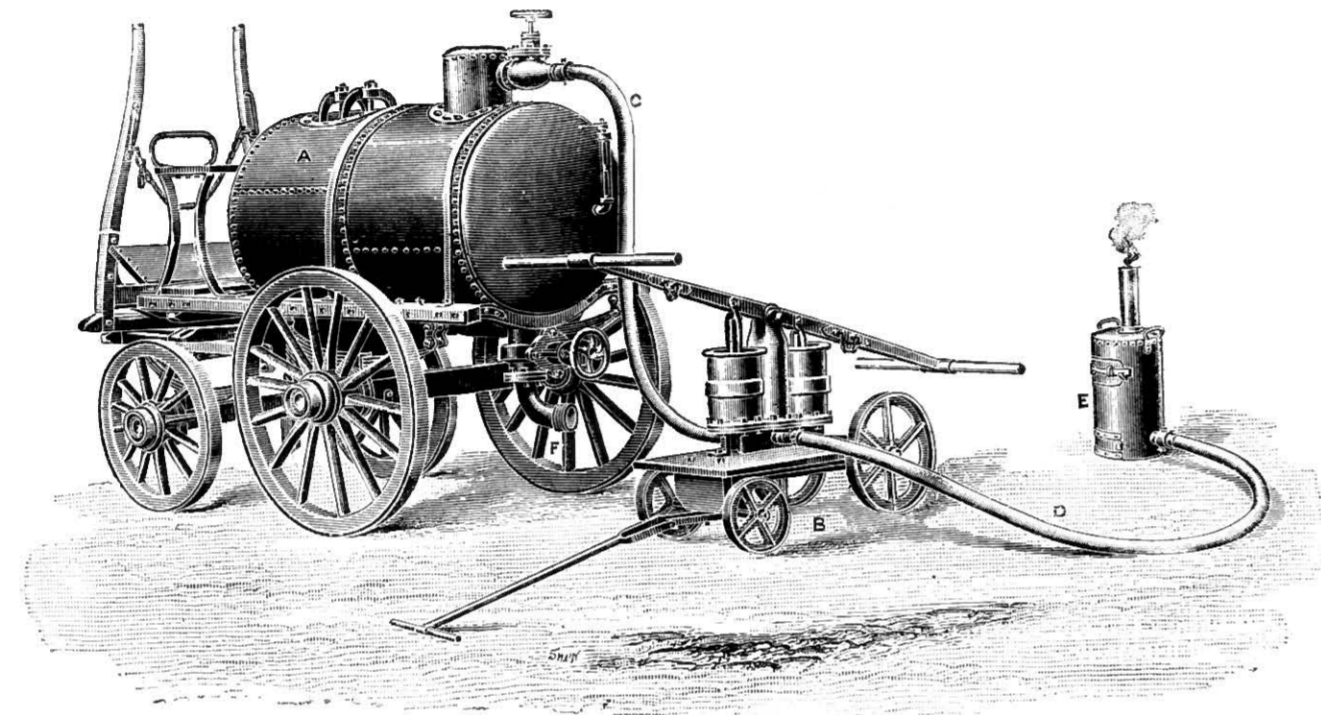

Fig. 443.—Merryweather's Pneumatic Cesspool-emptier.

receptacle for sewage, A, with dome and connecting-pipe, C, for producing a vacuum in the receptacle. The tank is provided with a man-hole for cleansing purposes, and inlet and outlet sluice-valves. A gauge-glass is also fitted, which gives indication of the quantity of matter in the receptacle. The whole is mounted on strong springs and patent axles provided with four wheels, and a driver's seat and footboard are also fitted. The vacuum pump, to be worked by two men, is of special design, and is mounted on a platform provided with four iron wheels, shown at B. A flexible air-pipe, C, is supplied for connecting the tank to the air-pump, and a similar pipe, D, for the conveyance of the gases to the stove, E, where they are burnt. Such a method as this is evidently an advance upon the usual methods, and should be adopted by all Local Authorities, who are responsible for the emptying of the cesspools in their districts.

A better plan than an ordinary cesspit would be, where it can be afforded, the introduction of one of "Cosham's Sewage-precipitation Tanks", where, with the addition of a small amount of chemicals, the sludge is deposited at the bottom of the tank, and the effluent may then be passed over land or land-filters, and

thus harmlessly soak away or pass into a stream or brook. Drawings of this tank and the adjacent screening and chemical chamber, are given in fig. 444.

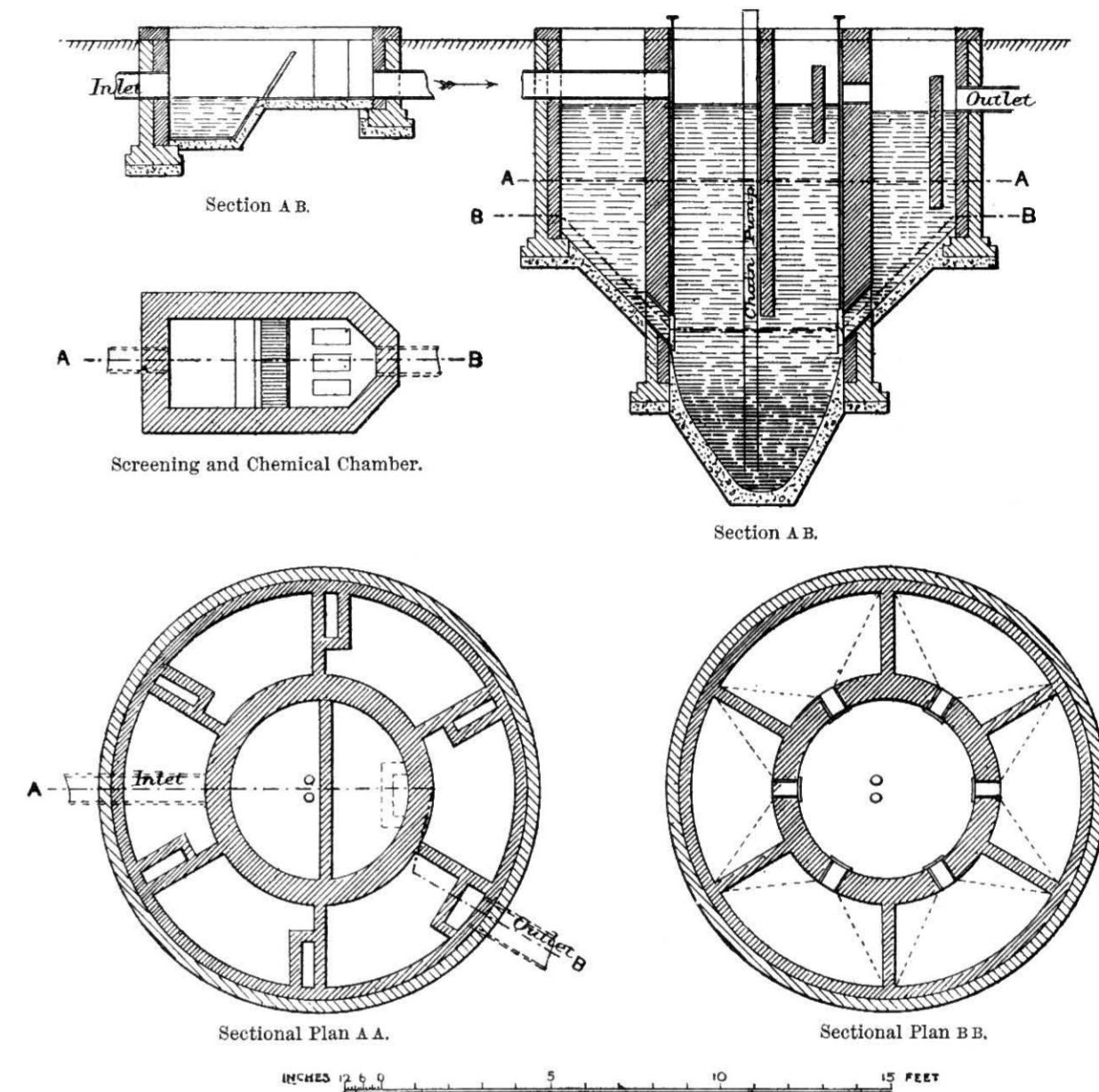

Fig. 444.—Cosham's Patent Sewage-precipitation Tank, with Screening and Chemical Chamber.

The above arrangement, or a "Septic" tank and filters, would make a very complete installation for a house of large size, but with respect to cottages and small houses, where there is but little land, the problem of the best method for dealing with the sewage is not easy of solution. Each case must be considered on its merits, and whether a cesspool is used, or earth-closets or privies, they must be of the best construction, and so arranged as to cause no nuisance and to be thoroughly sanitary in every sense of the word.

The Earth-closet is too well known to demand much description. It was the invention of a clergyman, the Rev. J. M. Moule, and has been in operation for a great number of years. It consists of an ordinary closet-seat, under which is



a metal container into which is dropped, either automatically or by means of levers, &c., attached to the seat, or by a scoop, a certain quantity of dry earth, which absorbs the moisture and deodorizes the fæcal matter.

The building in which such a closet is fixed should not be inside the house, but should be a separate building, or approached by a short passage with cross ventilation. It must be well lighted and ventilated, with an impervious floor of asphalt, cement, or tiles. The container beneath the seat should be constructed of galvanized iron, and should fit into guides so as to be always directly under the seat. It should be removable either at the back or front, and not contain more than about two and a half cubic feet, so as to ensure constant removal. The contents of the container can be used, with great advantage and perfect safety, in the garden attached to the house, however small.

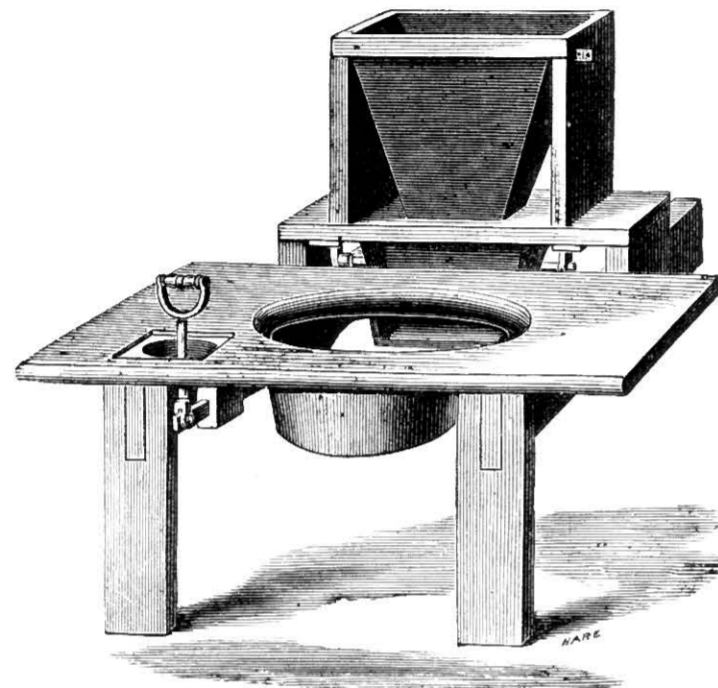

Fig. 445.—View of Moule's Earth-closet, with Pail removed.

Dr. George Vivian Poore, in an excellent book, *Essays on Rural Hygiene*, gives some good advice and practical remarks upon this subject. He says: "In order that the dwelling and its surroundings may be wholesome, it is essential that all excremental and putrescible refuse be removed *every day*. To allow such stuff to accumulate for a week before removal, as is done in some places where what is known as the 'pail-system' is in vogue, is quite indefensible, and I believe that a daily removal would be found easier of accomplishment than a weekly removal." He considers that the collected material should be at once buried, and as the material when once put under ground is safe, it might be shallowly buried close to the house and the ground cultivated. "If applied with care and knowledge, it can do nothing but good." No antiseptic must be mixed with it, as of course such admixture would kill its fertilizing properties and render the ground sterile, besides killing the microbes which Nature has provided to do the work of purifying.

Earth-closets are now made either to be operated by a handle, as shown in Fig. 445, or to be "self-acting", the motive power in the latter case being furnished by the weight of the person using the closet. A **self-acting earth-closet** of this kind is shown in Fig. 446. A reference to the illustration will

explain the nature and working of this closet. A is a magazine for containing the dry earth, or other deodorizing material used. B and B' are the sustaining pieces, which bear up the weight of the material, and also form the regulating orifice. C is a bevelled shelf, which is lined with a metallic plate, and carries in front an iron frame or mouthpiece, through which the perforated shovel or spreader D travels. The action is communicated as follows:—When the closet is being used, the seat is depressed about an inch, forcing down the rods EE on each side of the seat, which raise the long and weighted end of the segmental toothed levers G and G', which in turn throw back the long end of the lever H. This *duplex action* is coupled by the cross bar J, to which is attached the shovel D. This is then withdrawn to the back of the bevelled shelf C, and receives the charge of earth, &c.

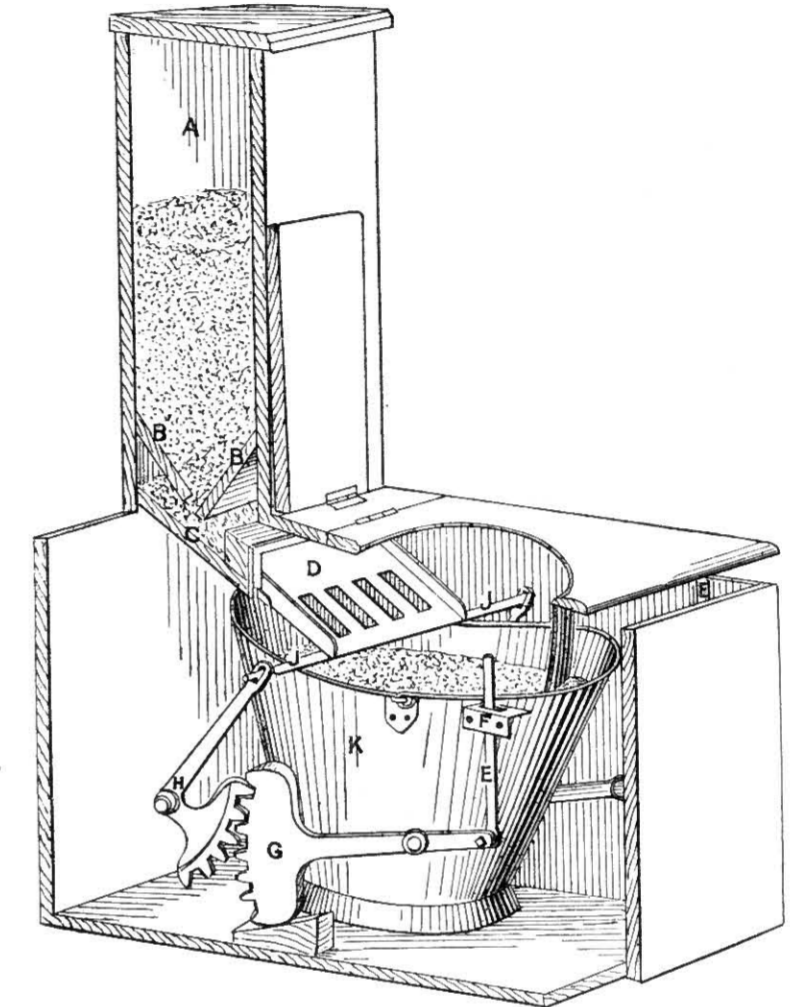

Fig. 446.—Sectional View of the British Sanitary Company's Self-acting Earth-closet.

When the seat is relieved, the weight of the lever brings out the shovel quickly, thus spreading the earth, &c., over the excreta.

**This concludes the remarks on Sewage-disposal.**—It is a difficult subject, as engineers, chemists, and the legislature differ on so many points connected therewith. No hard-and-fast rules can be laid down, but each case must be taken on its merits, and the choice of any system for the ultimate disposal of sewage must necessarily be left to the judgment of experts.



# SECTION X.—WARMING

BY

E. R. DOLBY

ASSOCIATE MEMBER OF THE INSTITUTION OF CIVIL ENGINEERS; MEMBER OF THE INSTITUTION OF  
MECHANICAL ENGINEERS; WHITWORTH SCHOLAR





## SECTION X.—WARMING.

---

### CHAPTER I.

#### INTRODUCTORY.

The subject of warming is one of the most important in the design of a dwelling-house, and the problem as to the best method to be employed in any particular instance, is not always easy of solution. Warming is so closely allied with ventilation that it will be impossible to avoid repeated mention of the latter subject, but fuller information thereon will be found in a subsequent section, written by another author.

So long as the temperature of the external air is above 60° Fahr., no system of warming will be found necessary in the British Isles, except in the cases of rooms or buildings occupied by invalids, where possibly a rise of a few degrees may be deemed desirable. When, however, the external temperature falls below 60° Fahr., some means of warming is desirable; and of course when the external temperature falls much below that point, it becomes essential to raise the temperature of the interior of the building, if the comfort of the inhabitants is to be obtained. Opinions vary in different countries as to the most desirable temperature for the interior of buildings; for instance, in the United States the internal temperature is often kept as high as 70° or even 75° F. Most Englishmen consider these temperatures too high for comfort, and it is generally agreed that a temperature of 60° F. is advisable in living-rooms, and about 55° F. in corridors. The temperature, however, should be kept constant, as directly fluctuations occur, there is a tendency to the production of draughts. In our climate, it is necessary to provide for raising the temperature of the interior of the building uniformly to 60° Fahr., when the external temperature is 25° Fahr. Even in the severest winter, the thermometer rarely falls below that degree of cold; and when it does, the apparatus, if properly designed, can be overworked to the small extent necessary.

The methods adopted and considered desirable in different countries vary so



greatly, both from the great differences in the range of temperature and from the prejudices of the various peoples, that I have thought it best to consider the question of warming in its restricted application to dwelling-houses in the United Kingdom, and in countries having approximately the same climatic conditions. Again, the dwelling-house may be considered under two different aspects: *firstly*, the ideal house which one would desire to have built and to occupy personally; and *secondly*, the house provided by the speculative builder, and bought, leased, or hired by the tenant. At the first glance, there may seem to be little difference between the two classes of houses so far as warming is concerned, but there is this essential distinction: if a house be specially designed by a capable architect, for a client who requires the building to be provided with a suitable system of warming and ventilation,—for the two points must be considered at the same time,—then the design may be arranged so as to obtain the most efficient system, so far as that particular house and local circumstances are concerned. Whereas in the other case, the system which can be applied is at best a makeshift and an addition, for it can rarely be said that the problem of warming receives very special attention from the speculative builder.

The systems in use may be divided into two groups: *firstly*, those in which the warming is produced from a number of separate and distinct heating-centres, such, for instance, as open fires; and *secondly*, systems in which the whole of the house is, or may be, warmed from a central source, which distributes the warmth over the building. I shall endeavour to point out the special advantages and disadvantages of the two systems, although in many cases it will be found desirable to use both systems jointly in the same building.

The chief requirements of a good system of warming are the following:—

(a) The apparatus should produce and keep up an equable warmth all over the building, or, at least, an equable warmth over every part of a given apartment.

(b) The apparatus should not vitiate the air in any way; that is to say, it should not give off objectionable fumes, smell, or gases, which can enter the apartment.

(c) The apparatus should not lessen the humidity of the air; that is to say, the humidity of the internal air should be such as would be found in external air, at the temperature of 60° F., on a still morning in spring.

(d) The apparatus should not require skilled attention, or be likely to explode, or to cause damage to property, even if somewhat carelessly handled.

(e) The apparatus should be of such a nature as to tend to promote ventilation, and in doing so should not impair the incoming air for breathing purposes.

In discussing the advantages and disadvantages of the various systems, the value of each will be assessed by the way in which it fulfils the above requirements.

In some kinds of warming-apparatus, provision is made for allowing the external air to enter through the apparatus, so that they provide ample ventilation and also warmth at the same time. In view of this, it may be desirable to glance at the **experimental data** which have been obtained. Some persons are much more sensitive to draughts than others, but the conclusions deduced by Sir Douglas Galton and others, from experiments, may be accepted, namely, that a current of air having a velocity of 3 feet per second causes no inconvenience, while a current with a velocity of 5 feet per second is objectionable, and one with a velocity of 10 feet per second is felt as a strong draught. A good deal of discussion has taken place from time to time as to the number of times per hour that the air in a room should be changed, and opinions have differed greatly. It is usually conceded that from 1500 to 1800 cubic feet of fresh air should be provided per hour per person, in order that the ventilation may be perfect; if the lower figure be taken, and a velocity of 3 feet per second be allowed to the incoming air, it is obvious that the area of the inlet must not be less than about 20 square inches per person. If this orifice be arranged so that the incoming air passes over or through the heating-apparatus, then the surface of the latter must be so calculated as to enable it to warm the volume of air to the required temperature.

## CHAPTER II.

### OPEN FIRES AND STOVES.

The open fire was the earliest method of warming houses, and many persons still consider it by far the best. In early times, it was usual to form the fire upon a solid hearth in the centre of the room or hut, and the smoke was allowed to fill the space, and to find its way out at a hole provided in the roof, either directly over the fire, or at some distance to one side in order that the rain might not extinguish the fire. The obvious objections to this system led gradually to the universal employment of special smoke-flues, and the inconvenience of the solid hearth led to the invention of the grate which could get rid of the ashes. It is interesting to observe, in modern slow-combustion grates, the employment of the solid hearth.



One or two essential points should be borne in mind in considering the subject of open fires. An open fire does not warm the air of the room by direct radiation to any appreciable extent, but the rays of radiant heat strike the solid objects, such as the walls and furniture, and these heat the air by conduction.

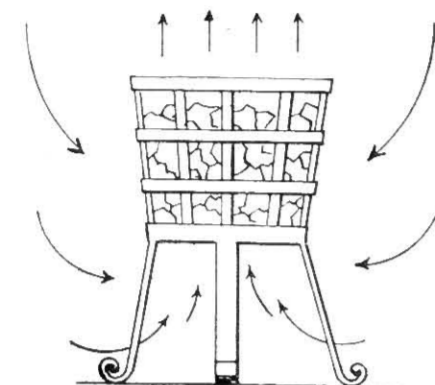

Fig. 447.—Currents of Air produced by an Open Fire out-of-doors.

A fire of course requires oxygen to keep it burning, and the action of combustion in a fire is of the following nature. Air as it is heated expands, and consequently becomes lighter, volume for volume; a fire therefore causes a column of heated air to rise, and its place is taken by colder air which descends. If the fire be burning out-of-doors in still air, the currents induced will be as shown in fig. 447. The rising of the heated column of air can easily be seen over a fire, or over a gas-jet or other source of heat. The air—a mixture of nitrogen and oxygen—is drawn into the lower part of the fire; the nitrogen is merely heated and passes away unchanged, but the oxygen unites with the carbon of the incandescent material, and forms carbonic acid gas ( $\text{CO}_2$ ). This gas rises through the heated mass, and is changed to carbonic oxide ( $\text{CO}$ ); it then combines with another atom of oxygen, and should pass away as carbonic acid ( $\text{CO}_2$ ), if there is perfect combustion. This is the same gas

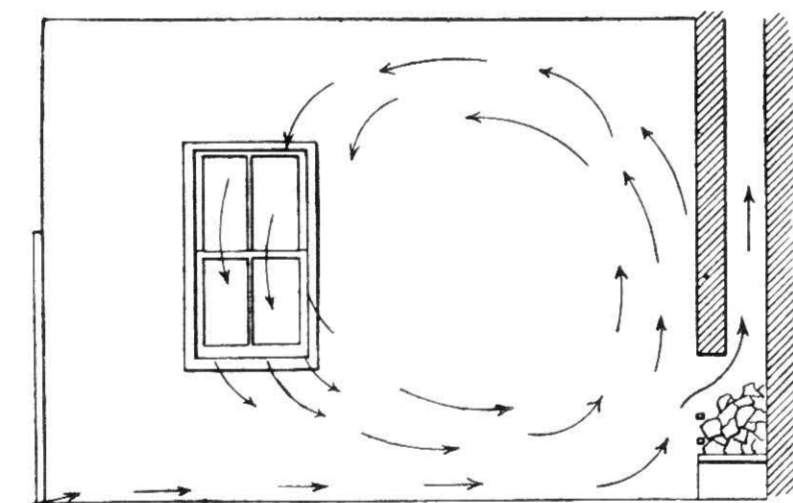

Fig. 448.—Currents of Air produced by an Open Fire in a Room.

which is produced by human beings and animals in breathing, and should not be allowed to pass into the atmosphere of a room, although this always takes place where coal-gas, oil, or candles are burnt. The presence of the gas is always undesirable, and when present in comparatively large quantities, it is dangerous to life. The action of an open fire upon the air in a room is represented in fig. 448, from which it will be seen that there is a constant current of heated air rising up the chimney, and to take its place air is drawn from other places, such as the cracks around the doors and windows; if these be carefully stopped up, the fire will not burn brightly but will gradually die out. There is always a current of cold air passing along the floor towards the fireplace. Part of this air passes directly up the chimney, and part is heated by contact with the fire-

place, and rises up the chimney-breast to the ceiling, passes along it, and, as it cools, descends again to the floor level. In a long room, therefore, it is necessary to provide two fires, as the beneficial influence of one will not extend the whole length.

place, and rises up the chimney-breast to the ceiling, passes along it, and, as it cools, descends again to the floor level. In a long room, therefore, it is necessary to provide two fires, as the beneficial influence of one will not extend the whole length.

Open fires are unsatisfactory for the purpose of producing uniform warmth throughout the whole air of a room, and also because cold external air from every crack, and the relatively cold air of the corridors, are drawn into the room, producing draughts. The feet of persons in the room are always subjected to a cold current of air, necessitating the use of stools to raise the feet above the floor. In order to diminish or entirely obviate this current, the external air may be brought in by a special duct discharging the air directly under the grate, as shown in figs. 449 and 450. This would supply the fire with air, and would certainly diminish the draught along the floor. It would, however, be a wasteful plan, as the entry of air at such a relatively low temperature, directly under the fire, would necessarily diminish its efficiency and cause a waste of fuel.

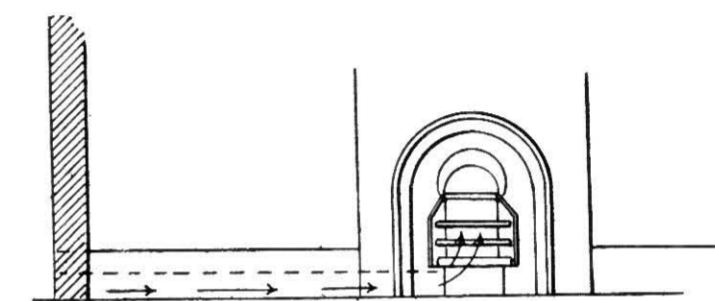

Fig. 449.—Elevation of Fire-grate, with Special Air-duct.

Many attempts have been made to obviate this objection, by passing the incoming air round a portion of the heated structure, before allowing it to come into contact with the incandescent fuel.

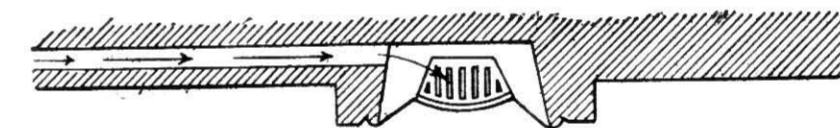

Fig. 450.—Plan of Fire-grate, with Special Air-duct.

The chief advantages of an open fire are its cheerful appearance, and the assistance it gives to ventilation. A good open fire-grate will conform to certain well-known principles. It must stand well forward. If a fireplace be set back from the room with a flue directly over the incandescent mass of fuel, a very large proportion of the radiant heat must pass directly up the chimney. The aim, therefore, of inventors is to throw the fire well forward into the room, to take away all parts of the structure of the fireplace which prevent direct radiation from the front of the fire, and to promote radiation from the back and sides of the structure.

In order to retain the heat and not allow it to be readily dissipated, the use of iron at the back of the fireplace should be altogether avoided. The next point is to avoid the use of heavy horizontal bars at the front of the grate, and to supersede them by vertical or curved bars, such as are shown in fig. 459, p. 75.



These bars, while effectually preventing the emission of cinders, allow a greater space for the free radiation of heat.

The **Nautilus Grate** is a kind of slow-combustion dog-grate, lined with fire-brick, and stands well forward into the room, but does not conform to all the principles just stated. A front view of it is given in fig. 451, and a section in

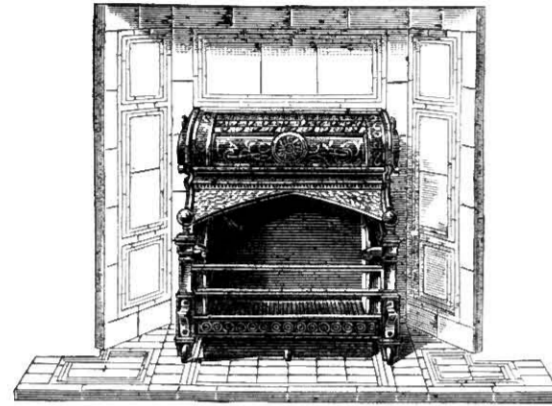

Fig. 451.—Front View of Nautilus Grate.

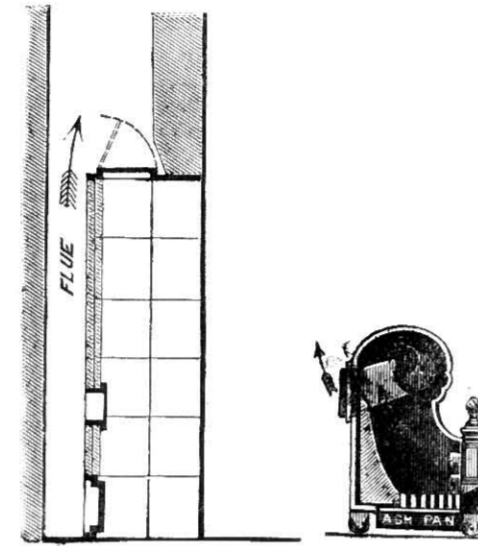

Fig. 452.—Section of Nautilus Grate.

fig. 452. One advantage of this grate is that it can be moved out in summer, allowing the space to be filled with plants. The products of combustion rise, and, after revolving within the central tube, pass off by the nozzles, which may be at the back or at the top; the ashes fall into the special ash-pan. It is usual to tile the sides of the fireplace and the hearth. It will be observed that heat is radiated from the whole exterior of the stove, which burns ordinary fuel, and is lighted in the same manner as any ordinary stove. The makers state that a fire 12 inches wide is sufficient

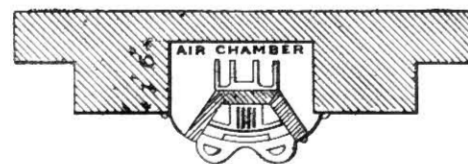

Fig. 453.—Plan of the Galton Grate.

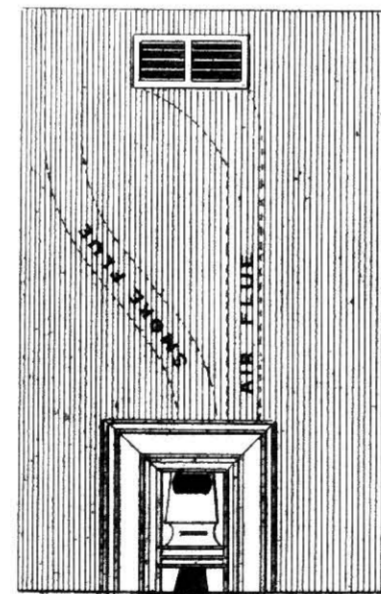

Fig. 454.—Elevation of Chimney-breast, showing Warm-air Flue, &c., from Galton Grate.

to heat a room of 2000 cubic feet capacity, and a fire 14 inches wide one containing 3500 cubic feet.

A special type of grate for warming incoming air was designed for the War Office by Capt. Douglas Galton (now Sir Douglas Galton), and has since become known as the **Galton Stove**. Fig. 453 is a plan of this grate; fig. 454 an eleva-

tion of the chimney-breast, &c., showing the warm-air flue, &c.; fig. 455 a section of the room; and fig. 456 an enlarged section of the grate itself. Fresh air is admitted to a chamber formed at the back of the grate, where it is moderately warmed by a large heating-surface; it is then carried by a flue, adjacent to the chimney flues, to the upper part of the

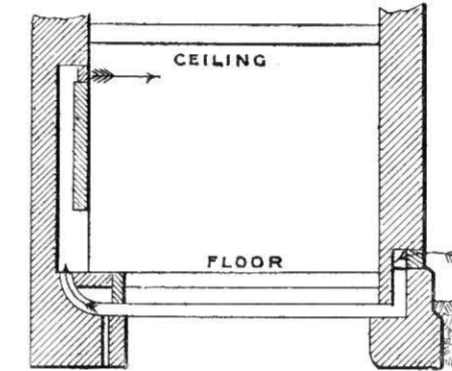

Fig. 455.—Section of Room showing Air-flues in connection with Galton Grate.

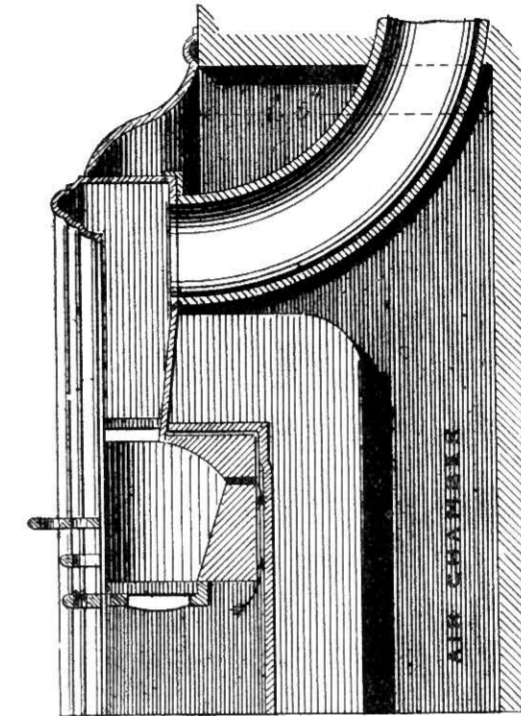

Fig. 456.—Section of Galton Grate.

room, where it flows with the currents which exist in the room. With this form of ventilating grate, the inventor states<sup>1</sup> that the temperature of a room has been found not to vary in any part to a greater extent than 1° or at most 2° F. The body of the stove is of iron, but the fire is placed in a fire-clay cradle; this prevents contact between the lighted fuel and the iron which communicates heat to the incoming air. The radiating surface obtained partly by the back of the grate and its flanges, and partly by the lower part of the smoke-flue, amounts to about 18 square feet.

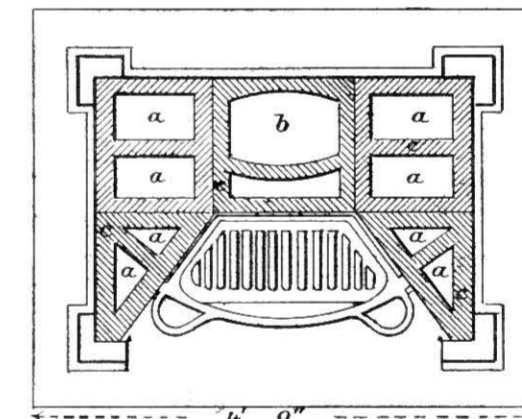

Fig. 457.—Plan of the Galton Independent Stove.

Another form of the **Galton Stove**, which is in use at the Herbert Hospital, Shooters' Hill, Greenwich, is shown in figs. 457 and 458, the former being a plan, and the latter a section. The chimney *b* passes under the floor, and is placed in the centre of the flue *a*, which brings the fresh air to be warmed by the stove. By utilizing the heat of the flue in this way, more than 36 superficial feet of heating-surface are obtained for warming the fresh air, beyond that afforded by the heating-surface in the air-flues, which is from 12 to 15 feet.

<sup>1</sup> See *Healthy Dwellings*, by Sir Douglas Galton.



The fire stands in an iron cradle, fitted to the fire-clay back and sides, and a current from the air of the room is brought through the fire-clay at the back of the cradle *c*,—where it becomes heated,—on to the top of the fire, to assist the combustion and thus prevent smoke. The top of the stove is coved inside, to lead the smoke easily to the chimney, which passes down into the horizontal flue *b* under the floor. The main body of the stove is a mass of fire-clay, with flues *a* cast in it, up which the fresh air passes from the horizontal air-flue already mentioned, in which the smoke-flue is laid. Thus all the parts of the stove which are employed to warm the fresh air and with which the fire has direct contact, are of fire-clay. The inventor considers that the use of fire-clay is distinctly preferable to the use of iron for such a purpose, as there is less danger of burning the air.<sup>1</sup>

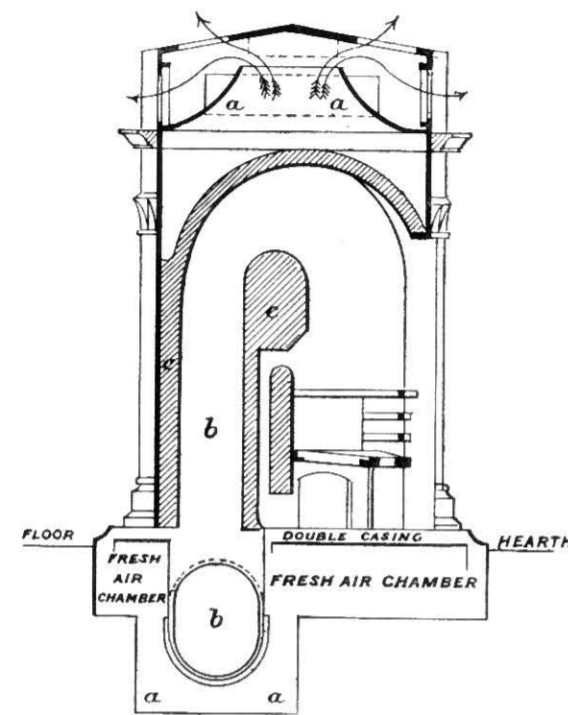

Fig. 458.—Section of the Galton Independent Stove.  
*aa*, fresh-air flues. *bb*, smoke-flue. *cc*, fire-clay.

The fresh-air opening through the outer wall is shown at *A*, or, if more convenient, it can be put lower down as at *B*, or carried as a channel along the skirting-board or below the floor-boards in either direction. The cold air, entering this flue, passes under the cast-iron base-plate *c*. If the inlet is at *B*, the air reaches the warm-air chamber *D* round the back of the fire-grate, and passes into the room through the warm-air duct *H*, which has a regulating valve *K*. The grating itself is lettered *F*, and the bars *G*, while the whole of the back of the fire consists of fire-brick, marked *E*. This grate is made in various sizes with various heating capacities.

The Grundy Grate is somewhat similar to the Galton grate, and is shown in Plate XVII.

It is obvious that the condition of the warm air entering the room will be, so far as purity is concerned, exactly the same as the external air, and if this is charged with soot, dust, or fog, these matters will be delivered into the room. In the grates described no arrangement is made to purify the incoming air, and while such fireplaces may be suitable for country-houses, they may not be satisfactory for town-houses. Another point is that, in order to obtain economy in the use of the fuel, it is desirable to block up the space between the grate and the hearth, but this point will be specially brought out in dealing with the following type of grate.

The Grundy Grate is somewhat similar to the Galton grate, and is shown in Plate XVII. It is obvious that the condition of the warm air entering the room will be, so far as purity is concerned, exactly the same as the external air, and if this is charged with soot, dust, or fog, these matters will be delivered into the room. In the grates described no arrangement is made to purify the incoming air, and while such fireplaces may be suitable for country-houses, they may not be satisfactory for town-houses. Another point is that, in order to obtain economy in the use of the fuel, it is desirable to block up the space between the grate and the hearth, but this point will be specially brought out in dealing with the following type of grate.

<sup>1</sup> The fire-clay, however, will more easily crack and so admit the smoke into the air-flues.—Ed.

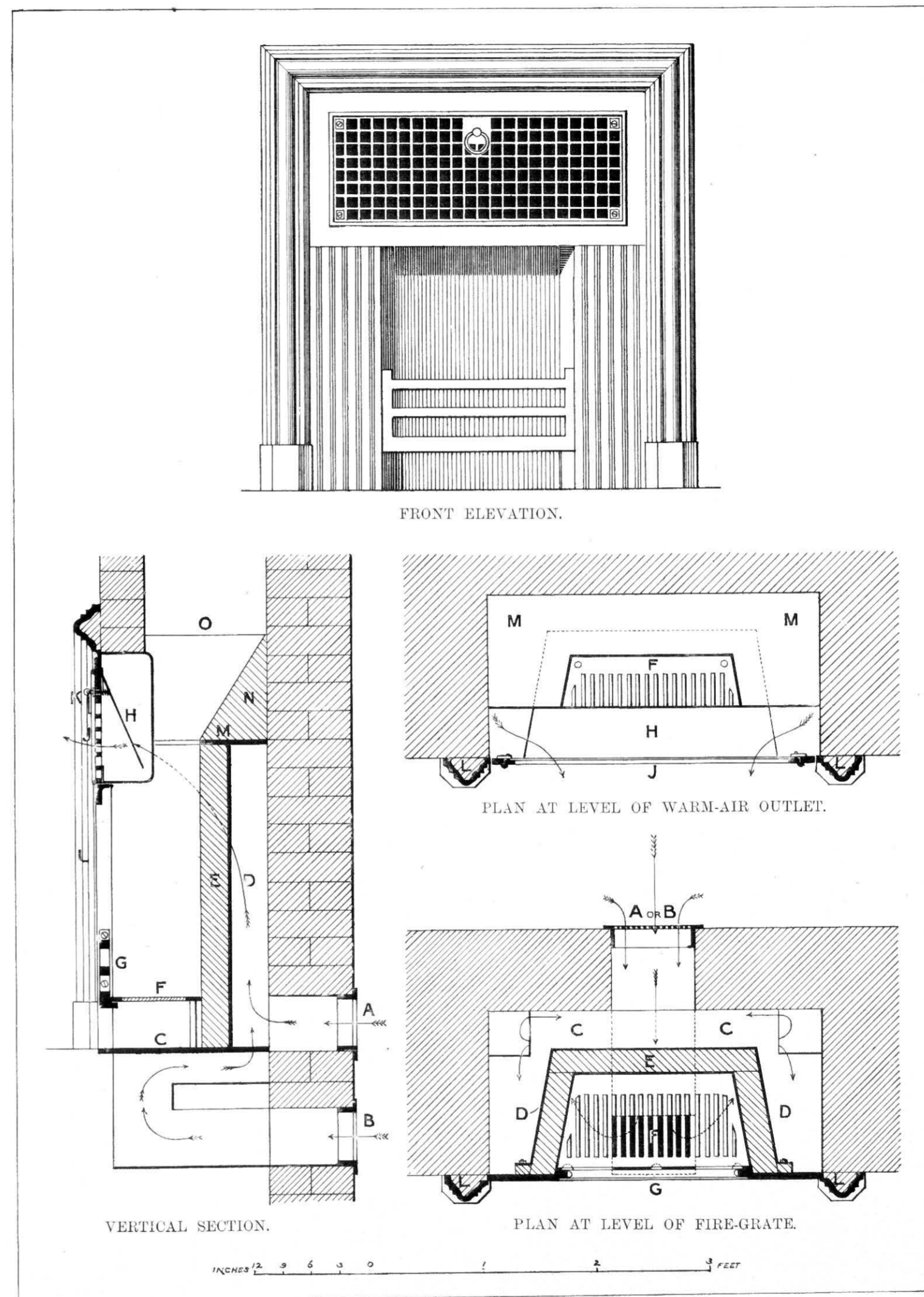

GRUNDY'S WARM-AIR VENTILATING FIRE-GRATE.

- |   |                             |                             |
|---|-----------------------------|-----------------------------|
| A. Fresh Cold-air Inlet Grating.                        | E. Firebrick Back.          | K. Regulating Valve.        |
| B. Fresh Cold-air Inlet Grating (alternative position). | F. Bottom Grate.            | L. Cast-iron Mantel.        |
| C. Cast-iron Base Plate.                                | G. Front Bars.              | M. Cast-iron Sealing Plate. |
| D. Warm-air Chamber.                                    | H. Warm air Duct.           | N. Brickwork Slope.         |
|   | J. Warm-air Outlet Grating. | O. Smoke Flue.              |



The Teale Grate owes its design, in the first instance, to Mr. Pridgin Teale, F.R.S., a well-known Leeds surgeon. He was convinced that the waste of fuel by incomplete combustion could be easily lessened, even in an ordinary fireplace, if due precautions were taken by means of simple and inexpensive additions.

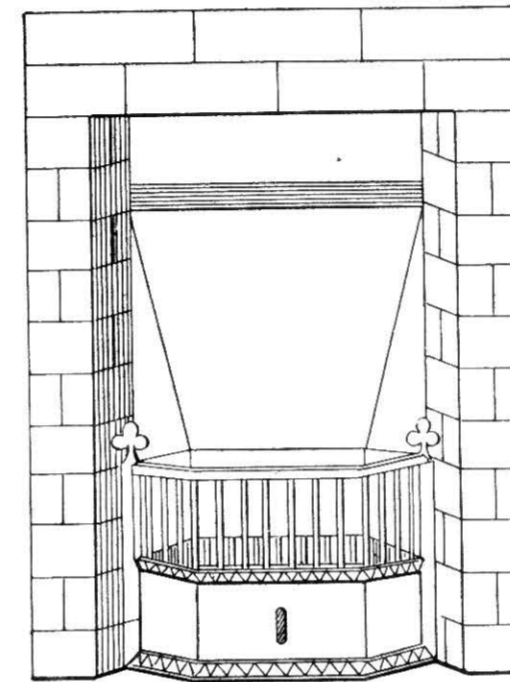

Fig. 459.—Front View of Teale Fire-grate.

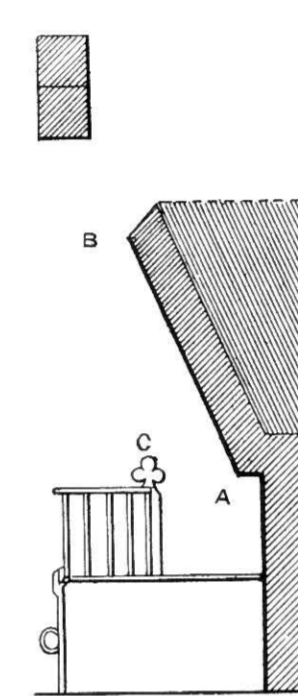

Fig. 460.—Vertical Section of Teale Fire-grate.

Fig. 459 is a front elevation of one of his grates, showing the thin vertical bars, and the economizer, consisting merely of a metal plate fitted in front. Fig. 460 is a sectional elevation, and fig. 461 a sectional plan. The points which Mr. Teale strongly insists upon are these: no air must be allowed to pass in below the grate at all; the space below the grate must be made into a closed hot chamber by means of the economizer; the slits in the grating itself should be made as narrow as possible, and the front bars should be as thin as possible. The whole of the air, therefore, which reaches the fire, arrives at or above the level of the fire, and he considers it desirable to have a solid band, about  $1\frac{1}{4}$  inches deep, at the bottom of the bars to hide from view the cinders and dust which are produced. The bottom of the grate should be deep from back to front, probably not less than 9 inches for a small room, or more than 11 inches for a large room. The inventor also lays stress upon the necessity for keeping all

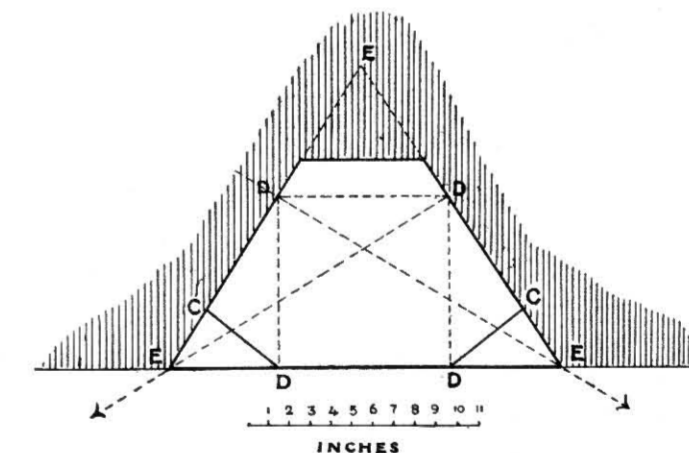

Fig. 461.—Plan of Teale Fire-grate.



iron away from the fireplace, and proceeds to describe the best form for the fire-brick walls and sides as follows:—

“The sides or ‘covings’ of the fireplace should be vertical, but inclined to one another as the sides of an equilateral triangle, the apex of which would be behind the fireplace, and the base would be in a line with the front. The working out of this rule has cost me much thought and experiment. It was worked out more or less empirically with a view to obtain certain objects, and having attained them I discovered that I had unwittingly selected the sides of an equilateral triangle. It is of some importance, and may be of interest, to tell how the question arose. In my earlier fireplaces, the sides or ‘covings’ were parallel to each other, and had the defect that they radiated most of their heat from one to the other, not into the room, with the probable result that much of such heat would eventually escape up the chimney. It was clear, then, that the sides must be set at an angle with the back, so as to face towards the room. But at what angle? My first experiments were determined by the shape of the corner bricks which were in the market. These determined the inclination of the sides to be such that, if prolonged backwards, they would meet at a right angle. This is the angle laid down by Rumford as the angle of selection, but as the largest angle admissible in a good fireplace. This angle, however, brought me into difficulties with my ‘lean-over’ back. The openness of the angle made the back, as it ascended and inclined forwards, spread out so rapidly, that what was gained in width was lost in height. Moreover, my critics objected to its appearance as ugly. What then should determine the inclination of the sides? The point was thus determined. Seeing that a heated brick throws off the greatest amount of radiant heat at a right angle with its surface, the ‘covings’ should be at such an inclination to each other, that the perpendicular line from the inner margin of one ‘coving’ should just miss the outer margin of the opposite ‘coving’. Where the ‘covings’, as in my earlier attempts and in Count Rumford’s fireplaces, are at a right angle to each other, this perpendicular line misses the opposite margin by several inches. It was clear, therefore, that the inclination might be made more acute. Guided by this idea, and having determined the principle on which the shape of the grate should depend, an inclination was arrived at which turned out to be an angle of  $60^\circ$ , *i.e.* the inclination of the sides of an equilateral triangle.

“Commencing at a level A, corresponding with the top of the front bars, and leaning forward at an angle of  $70^\circ$  with the horizontal line of the hearth, the back should rise to such a point, that the angle where it returns towards the chimney B should be vertically over the insertion C of the cheeks of the fire-

grate. This angle B will be about 28 inches from the hearth, or 16 inches from the top of the fire, and about  $3\frac{1}{2}$  to  $4\frac{1}{2}$  inches from the front line of the fireplace, according to the size of the grate.” These points will be obvious from the vertical section of the fireplace given in fig. 460, and from c in fig. 461.

“The shape of the grate or grid is arrived at in the following way:—Describe a square D—of which the sides shall be 8, 9, or 10 inches, according to the size of the room—within an equilateral triangle E, the two sides of which shall represent the ‘covings’ of the fireplace, and the base the front line of the fireplace. From each front angle of the square, carry a line from D to C to the ‘covings’ or sides of the triangle, at an angle of  $45^\circ$  with the front line of the fireplace. These two lines, with the side of the square from which they are drawn, form the front of the grid. The back line of the grid does not correspond with the corresponding side of the square, but is carried  $1\frac{1}{2}$  inches farther back, so as to give greater depth to the grate, and allow the fire-brick back to overhang the back of the grid to the extent of  $1\frac{1}{2}$  inches (see fig. 460), before it ascends as the ‘lean over’.”

The Teale grates are now made in a great number of designs; there are, however, only **two main types**. Fig. 462 illustrates the first type, and clearly

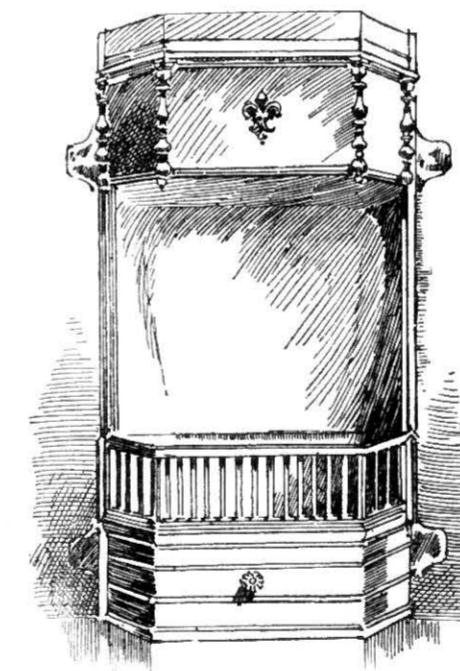

Fig. 462.—Front View of the Teale Fireplace.

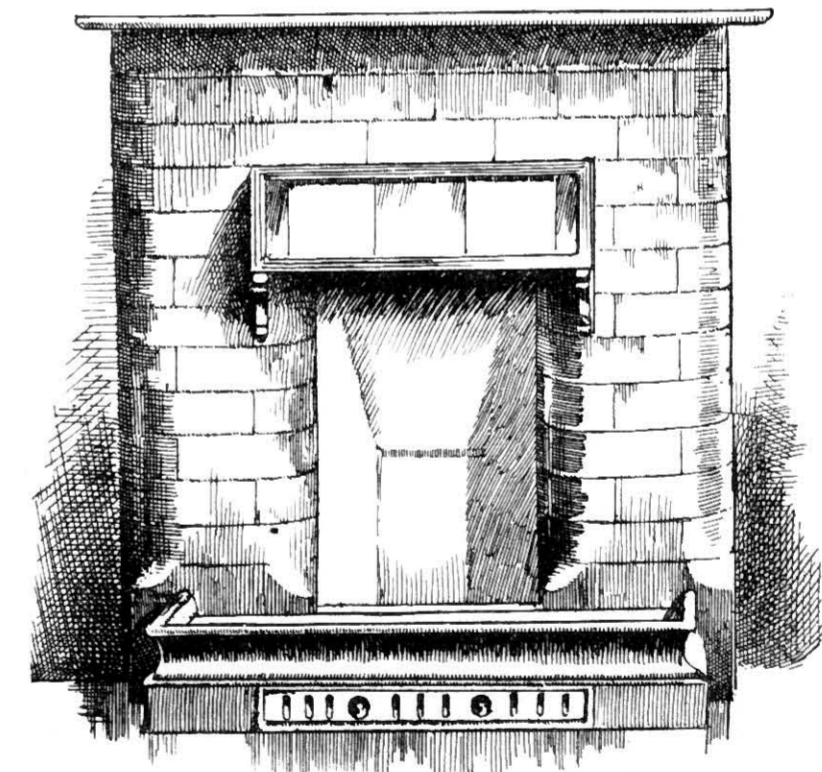

Fig. 463.—Front View of the Teale Front-hob Grate.

shows the economizer, the vertical bars, the solid fixed rim forming the base of the bars, the fire-brick back leaning forward and standing out at the bottom away from the back of the hearth proper, and the “covings”.

The second type, known as the **Front-hob Grate**, is illustrated in fig. 463.



This has no fire-bars whatever; the fire-clay back and sides are as already described, but the grate is only very slightly above the level of the floor of the room, and a special tiled hearth is built up. This becomes hot, and gives off heat to the room, and thus adds to the efficiency of the grate. Access is afforded to the ash-pit by means of the loose door shown in front, but as this door is provided with several air-inlets, the original Teale principle is departed from to some extent. This type of grate has been found extremely satisfactory.

The **Rational Grate** is another good fireplace, not unlike the last, but the ash-pit is sunk below the level of the hearth instead of being raised above it. A section of this fireplace will be found in fig. 71, p. 131, vol. I.

**Boyd's Grates**, while having the good points of the original Teale design, also possess several other features of interest. Figs. 464 and 465 show a grate with

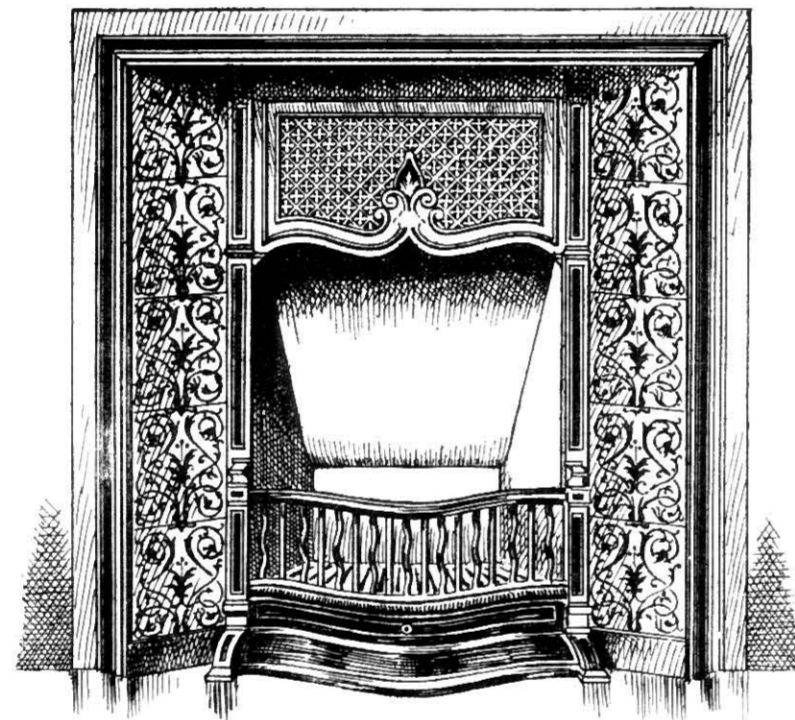

Fig. 464.—Front View of Boyd's Register Grate, with Adjustable Canopy and Regulating Ash-pit.

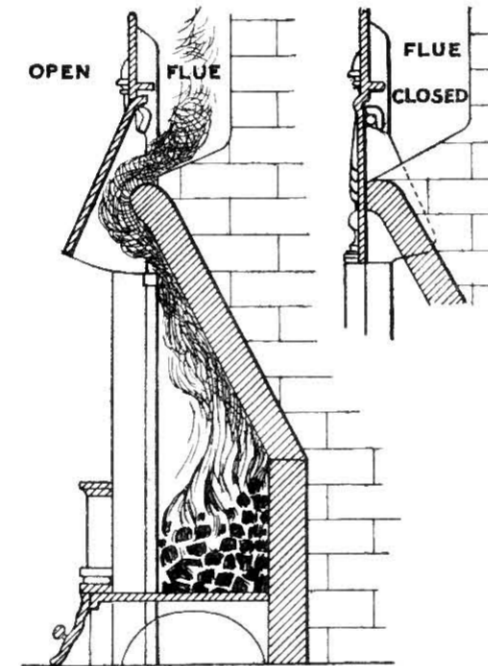

Fig. 465.—Vertical Section of Boyd's Register Grate, with Adjustable Canopy and Regulating Ash-pit.

an ash-pit which may be entirely closed for slow combustion, or opened to any extent desired by simply moving forward the economizer. It has the thin vertical bars and the fire-brick back, but the back slants even more forward than in some of our earlier illustrations, and the canopy register is of a good design, easily regulated to enlarge or diminish the mouth of the flue. The makers of these grates differ from Mr. Teale as to the most desirable angle between the sides and back, preferring an angle of  $135^\circ$ . It is extremely important to keep all the ironwork away from the fire, and this firm has even gone so far as to make the grating itself of fire-clay with slits, as shown in fig. 466. The special

stand for the fire-brick bottom is made of iron, and has an adjustable slide for closing the air-slits. The size of the fireplace can be diminished by the use of suitable blocks, which are specially made to fit the various grates.

The power of a given fireplace may be greatly increased by making it of such a form as to allow the air in the room to circulate round it. This is done in the case of the fireplace shown in fig. 467. In the plan, A is the fuel-basket, B the warming-chamber, and C the brick setting at the

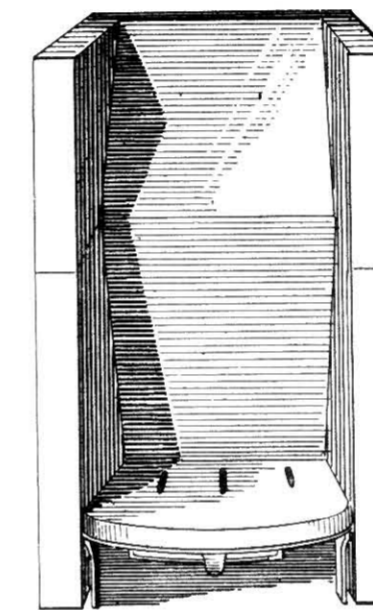

Fig. 466.—Boyd's Grate-body and Grating of Fire-brick.

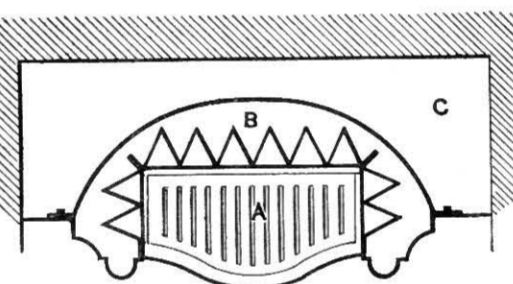
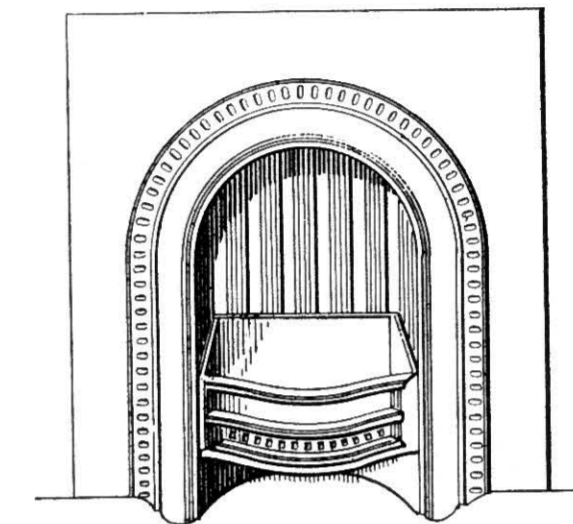

Fig. 467.—Plan and Front View of Boyd's Warm-air Grate.

back; the V-shaped projections are of iron, and afford a large heating-surface to the air, which passes in at the lower holes and out, in a warmed state, at the upper holes. Such a chamber should be occasionally cleaned out, otherwise it will become choked with dust, and will deteriorate the quality of the air passed through it. The iron just at the back of the fire is protected by fire-brick.

**Heim's "Helios" Smoke-consuming Grates** are really stoves, the fire being entirely inclosed. They are specially designed to consume their own smoke. The one objection to them, in the minds of many people, is that the fire itself is inclosed, and the flames can only be seen through a mica door. The design, however, is very ingenious, and well worth describing. The National Smoke Abatement Institution has reported as follows respecting these stoves:—"In the course of twenty minutes the smoke entirely ceased, and the chimney was entirely smokeless during the remainder of the trial. The performances of both



the grate and the stove stand, in point of economy of fuel and efficiency, in the front rank. The fires burned with perfect continuity and regularity, and they were practically automatic in action."

Two views of the Helios fireplace are shown in fig. 468. When the Helios Stove is used with a hopper, it consists of the fire-box A, which is lined with fire-bricks, the hopper B, and the pipe-system C. Under the grate R is

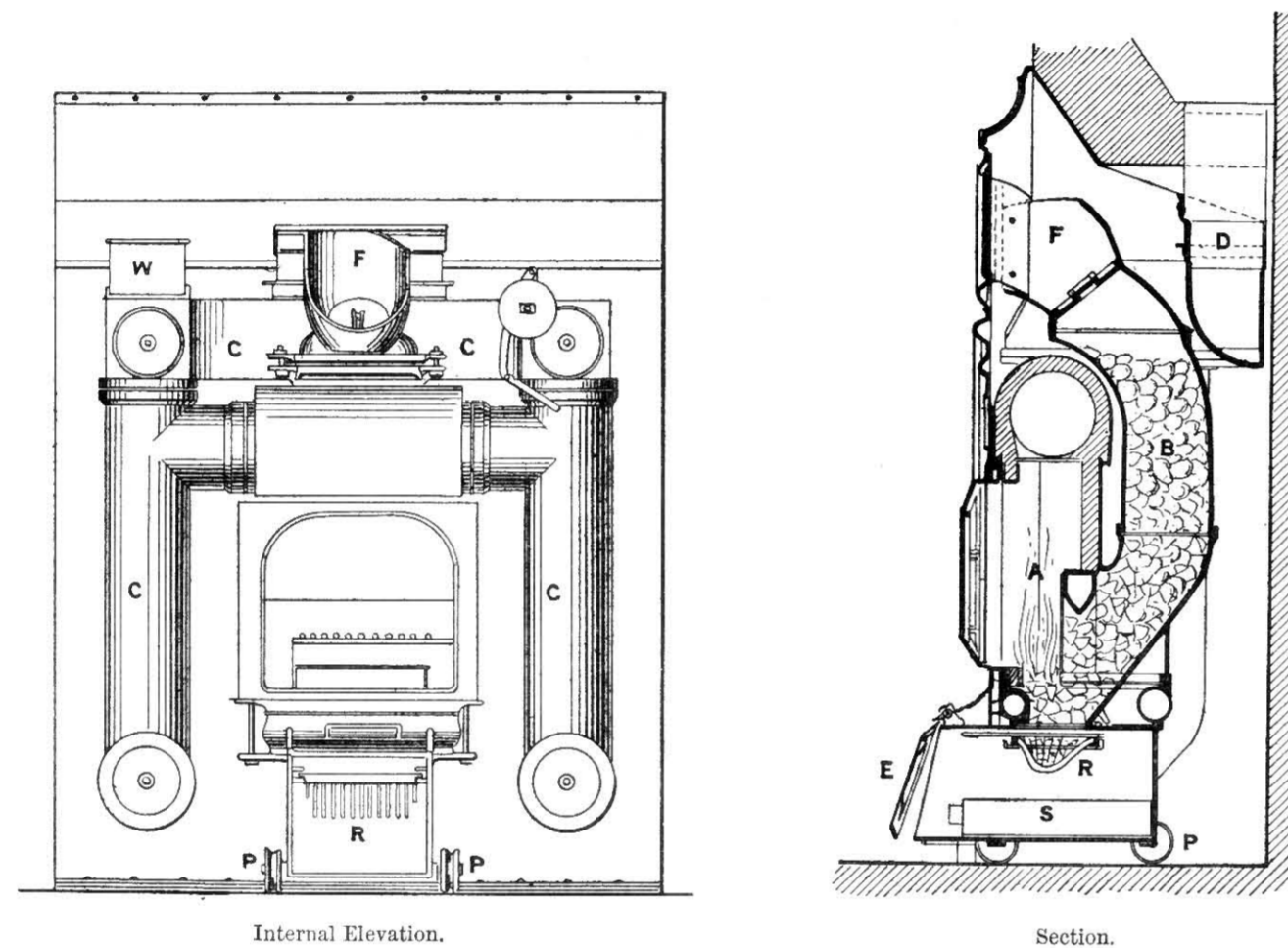

Fig. 468.—The "Helios" Smoke-consuming Stove.

arranged the ash-pan S and the regulating door E. The grate is fed by opening the filling door, and removing the cover in the filling neck F. In the Helios Grate without hopper, the hopper B, the pipe-system C, and the filling neck F are abandoned. The front of the combustion-chamber above the grate is covered by a hinged mica window, which allows the fire to be seen, and possesses the notable advantage of preventing soot, smoke, or burning coals from falling into the room. The whole apparatus is firmly screwed together, and stands on small wheels P, so that it is not a fixture. The heat is diffused partly by radiation and partly by warmed air. The fire heats by radiation through the mica window, and the pipe-system warms the air, which enters cold at the gratings at the bottom of the front, and is returned to the room in a

heated condition through the top perforations at the front. The perforations and mica windows are clearly shown in fig. 469.

By pushing the regulating door as far to the right as possible, the maximum combustion is obtained, while, by moving the door more or less to the left, combustion can be regulated so as to yield the exact degree of heat required. If the

regulating door is quite closed, the fire merely smoulders, and, according to the maker's catalogue, burns in that condition about 7 oz. of coal per hour. Economy of fuel is guaranteed by a large area of heating-surface, and perfect control of combustion; and consumption of smoke is attained by injection of pre-heated air on the smoke arising from the fuel. Perfect consumption of smoke is,

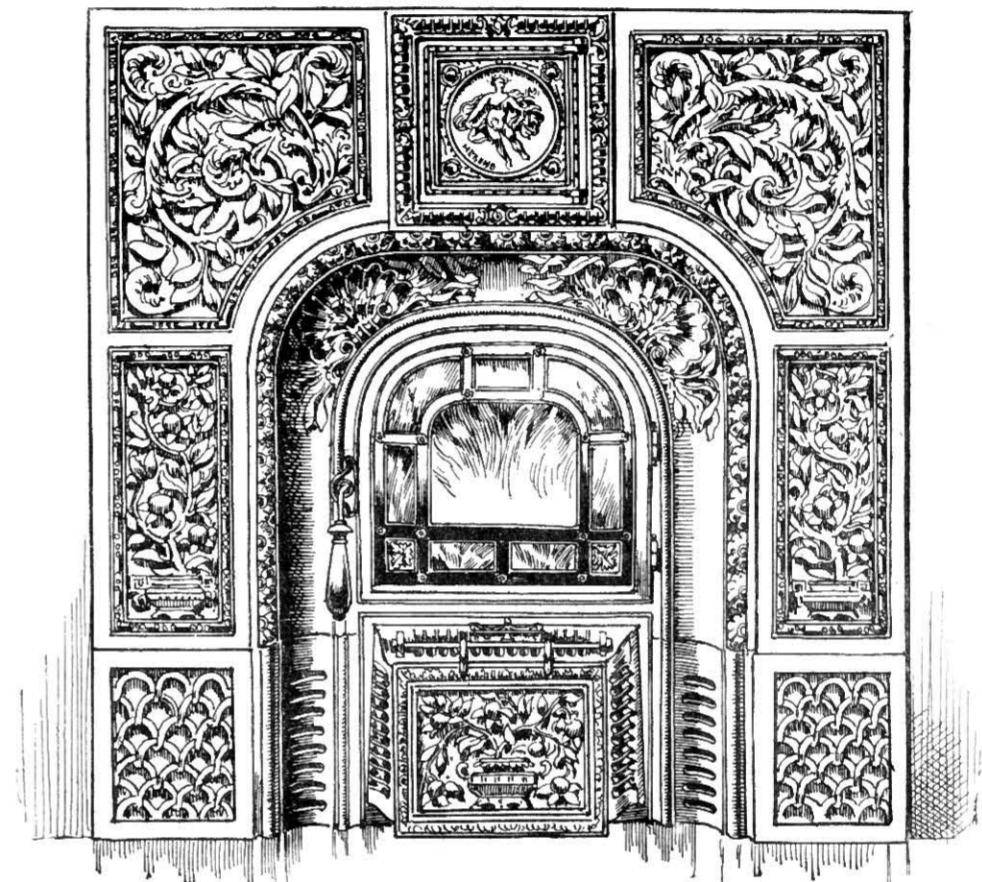

Fig. 469.—Front of the "Helios" Smoke-consuming Stove.

of course, most important from a hygienic point of view. In grates with hoppers, one charge, it is said, will last from four to twelve hours, according to the heat required. The fire will smoulder all night without attention. To revive it in the morning, it is only necessary to open the regulating door. The replenishing does not affect the burning fuel, so that the fire can be kept alight as long as required. Grates without hoppers hold fuel for 1½ to 4 hours, according to the heat required. Cleaning is necessary once a year. When the heating-chamber is to be cleaned, the grate should first be wheeled out.

In order to moisten the air, a vessel, which must be daily filled with water, is placed inside the chimney breast. Either the air in the room itself may be passed through the stove, or cold external air may be introduced, warmed, and sent out. Besides this, by an arrangement of suitable flues the warmed air produced in one room may be caused to heat one or two rooms directly over the first. The system then becomes one of heating by warmed air.



These grates, with or without fronts, can be easily inserted into existing mantel-pieces; they are not fixtures. The body of the apparatus surrounding the grate is divided into three parts by fire-bricks; the fire-grate itself forms the middle division. Above this there is an air-channel conducting heated air to the flame, in order to bring about smokeless combustion; above the air-channel there is a register, for the purpose of either allowing a direct draught into the chimney, as in an ordinary grate, or to send the products of combustion through the flues at each side of the grate. These flues can easily be cleaned by removing the cleaning covers, which can also be used as ventilators. In front of the grates there are two sliding mica doors, or one mica door on hinges. The grates are fitted with fronts entirely of cast-iron, or with tile panels, behind which the mica doors slide when opened sideways.

The process of warming can take place in three ways:

(1) If the mica doors and the register at the back are closed, the fire burns with a nice lambent flame according to the position of the lower sliding door, and the grate yields the greatest amount of heat.

(2) If the mica doors are closed, but the register at the back is left open, the grate still burns as described above, but as there is a direct draught into the chimney, only a small quantity of heat is given off into the room.

(3) If the mica doors are open as well as the register, the fire burns as it does in any ordinary grate, and gives hardly any heat into the room, but simply assists the ventilation.

Ventilation can be obtained by opening the valve in the cleaning covers at the bottom of the side flues; the air from the room will at once be drawn into these flues, giving ample ventilation for several persons. The draught for the fire will be slightly reduced thereby.

The "Hestia" Stove, also invented by Mr. Heim, is a true stove, standing away from the wall of the room,

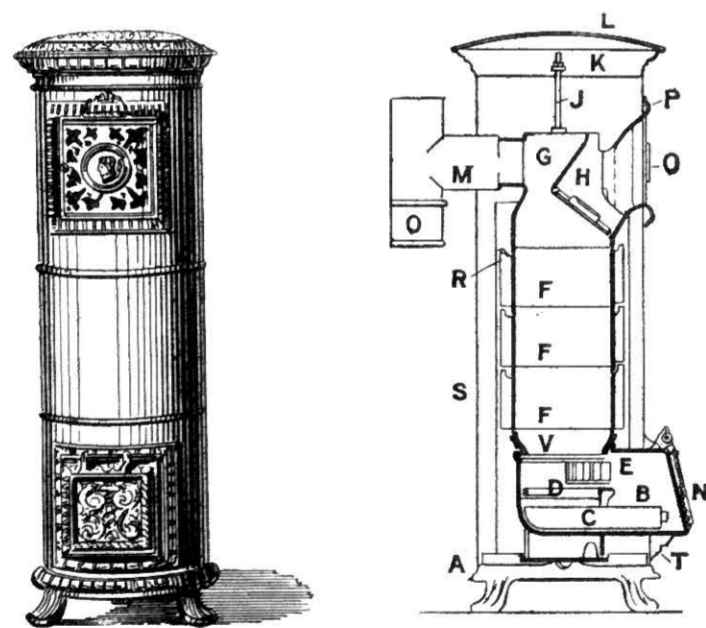

Fig. 470.—View and Section of the "Hestia" Stove.

and is shown in fig. 470. It stands on a plain or ornamental pedestal A, and consists of the regulating neck B, with regulating door N, movable grate D, fixed grate E, guard-ring V, one or two middle rings F, filling neck G, with smoke-nozzle and smoke-pipe M. The whole is held together and connected with the

pedestal by two iron rods J. This cast-iron heating-cylinder is surrounded by an inner sheet-iron casing R, and an outer one S, resting on the pedestal. The upper part contains the flat filling-door O, with frame P, and the top is surrounded by a cast-iron border K, carrying a perforated cover L. The smoke-pipe M is connected with the flue by ordinary smoke-pipes. In the regulating neck is the ash-pan C. The poker serves the double purpose of raking out the fire and lifting off the filling cover H. In many cases where iron stoves are used for heating purposes the dryness of the air is a source of complaint; in order to prevent this, the "Hestia" stove has a water reservoir suspended between the inner and outer casing, but free from both, so that the water may become very hot but cannot be made to boil. The reservoir is supplied by a tube opening upwards, projecting from the side of the casing, so that it can be easily filled without removing the cover of the casing. All the fuel is lighted from the top, and combustion proceeds downward, so that smoke and gases must pass through the fire, and are thus consumed before reaching the chimney. As the fire is drawn downward it goes out on the top, so that, in stoves with the several middle rings, black coke is visible on the top, sinking gradually down during the combustion. A further proof of the complete utilization of the fuel, is the fact of the smoke-pipe being almost cold.

In order to burn coal without smoke, it must be changed into coke. This cannot be done in an open grate, and the arrangement invented by Mr. Heim affords, in my opinion, a very satisfactory solution of the problem, as the thick heavy smoke, which is given off from the coal, is passed through the incandescent mass on its way to the chimney. There is no doubt whatever that the coal can be burnt without producing smoke, except during the first twenty minutes (say) after lighting, and a choice must be made between the cheerful appearance of an open fire, and the efficient consumption of the fuel in a closed stove.

The Falkirk Iron Company makes a stove, which is called a "Controlled-combustion Air-chamber Heating Apparatus". It consists of an internal stove and an ornamental perforated cast-iron external case, with an air-space between. The plan of the apparatus itself without case is shown in fig. 471, a vertical section in fig. 472, and a front elevation in fig. 473. The bottom and sides of

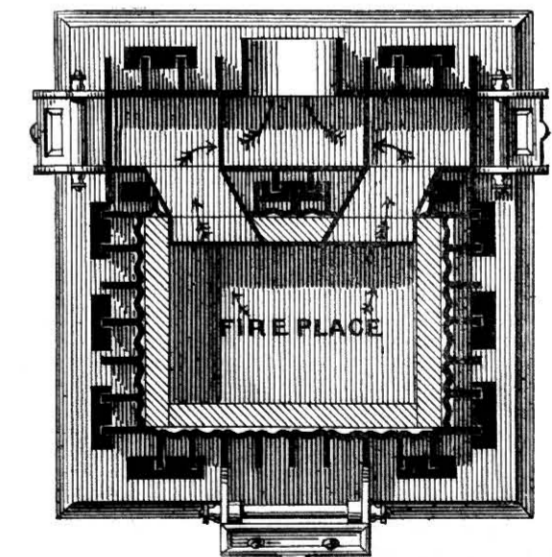

Fig. 471.—Plan of One-chambered Controlled-combustion Heating Apparatus.



the fire-grate are of fire-brick. Fuel is inserted at the top, and the smoke-flue descends at the back. The fire-chamber is provided with vertical ribs outside, which project into the air-chamber between the stove itself and the external case. The surrounding air enters at the base of the apparatus, through the holes shown, and passes vertically upwards, and then through the ornamental casing, thus acting as a means of heating by warmed air. If the stove be placed

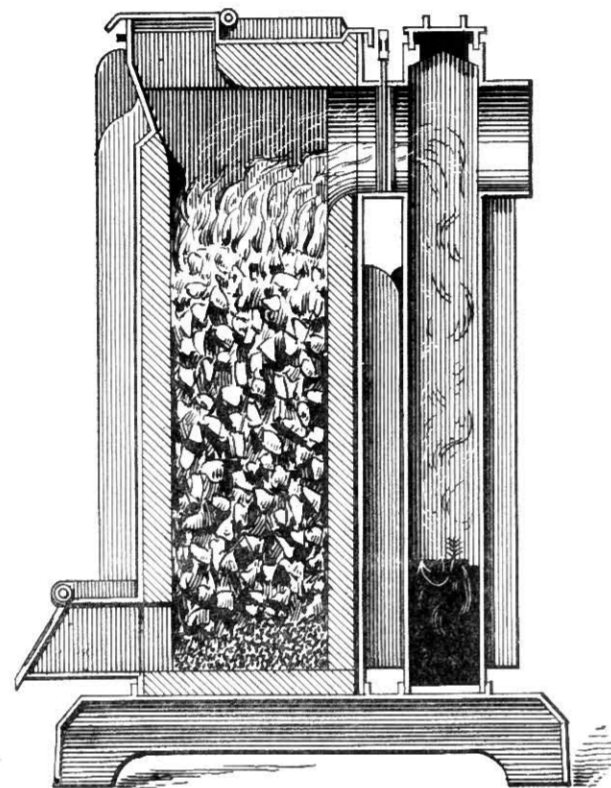

Fig. 472.—Vertical Section of One-chambered Controlled-combustion Heating Apparatus.

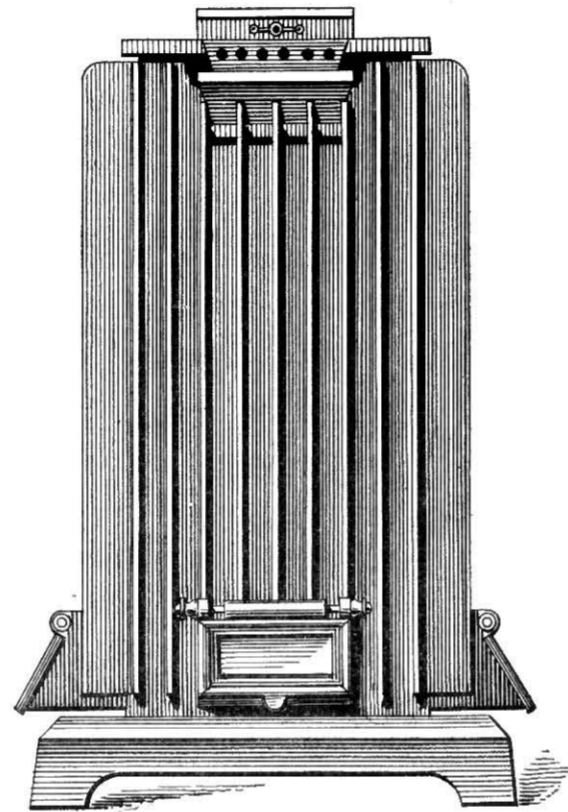

Fig. 473.—Front Elevation of One-chambered Controlled-combustion Heating Apparatus.

over a hole in the floor, connected with an air-duct from the external air, more efficient ventilation will be secured. The makers state that a one-chambered apparatus, as illustrated, with the draught-valve at slow-combustion (or open only  $\frac{1}{4}$  to  $\frac{2}{8}$  of an inch), will consume 2 lbs. per hour of gas-coke, and heat an apartment containing 40,000 cubic feet of air, at a cost of less than twopence for twelve hours. An evaporating pan placed under the base of the apparatus is found desirable to moisten the atmosphere. The heating-power of the stoves made by this firm vary from 10,000 to 140,000 cubic feet, according to the size of the apparatus. Such a stove is adapted for use in a large hall, and would warm the whole of the staircase and corridors with far less consumption of fuel than would be the case with an open grate.

The **Shorland Grate** is of the Galton type with a Teale hearth. A section is shown in fig. 474. The back of the grate is of fire-clay, and projects well forward above the fire. Behind it is the warm-air chamber, to which the cold external

air is admitted through a grid in the outside wall. From this chamber, it rises through two special warm-air flues, and is discharged into the room, at a height of about eight feet above the floor, through a hit-and-miss grating. It is of course easy to carry the pipe up through the floor, so as to deliver warm air into a room above. I have already drawn attention to the undesirability of drawing the external air into rooms in town-houses, without previously filtering it in some manner.

The makers say: "In preparing new buildings to receive the Patent Manchester Grates, the best and simplest plan is to build common

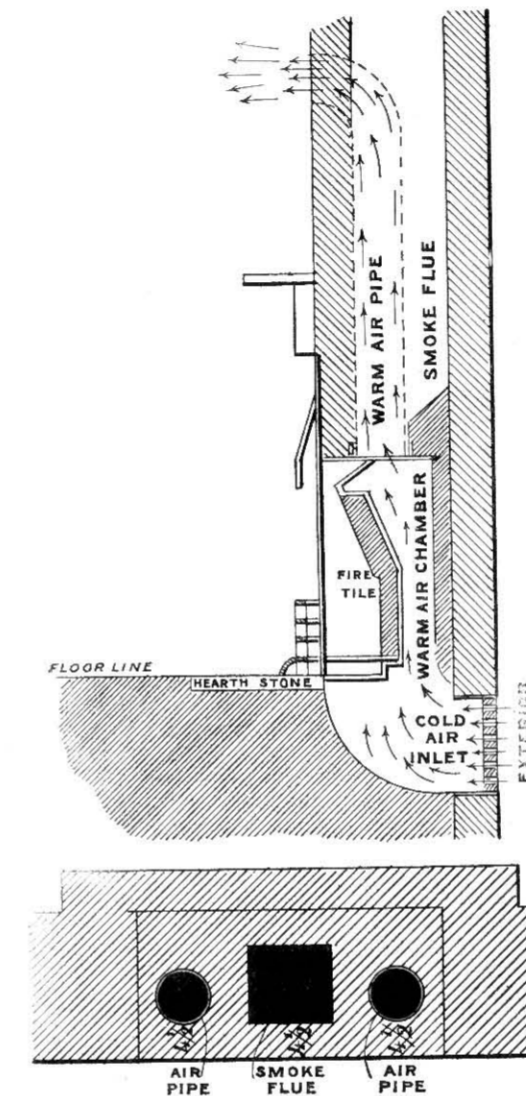

Fig. 474.—Vertical Section of the Shorland Grate and Plan of Flues.

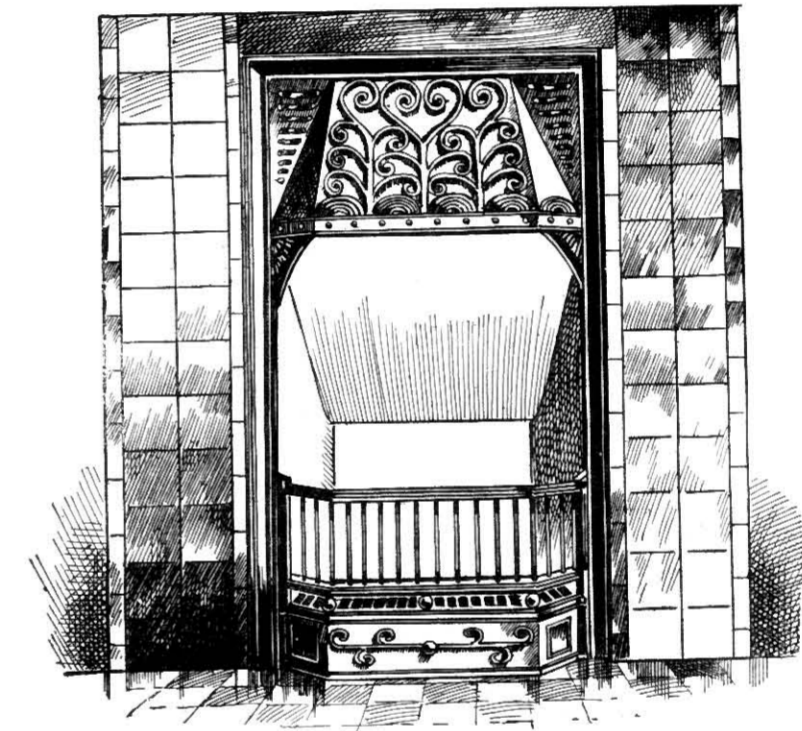

Fig. 475.—Front View of Shorland's Fireplace.

6-inch socketed clay drain-pipes in the solid brickwork of the chimney breast, as the building progresses, for the warm-air flues, keeping them 18 inches apart,  $4\frac{1}{2}$  inches from face of brickwork, and commencing 4 feet from floor (socket end upwards). Use square elbows to deliver the warm air into the room through the face of the breast, at about 8 feet from the floor. Then when the building is ready to receive the Manchester grates, they simply require connecting to the clay pipes by means of our own syphon pipes or other connecting pipes. The outside cold-air grids should also be built in as the building progresses." For size No. 1, the opening in the brickwork must be 48 inches high, 30 inches wide, and 14 inches from back to front, and the heating capacity is 3000 cubic feet of space, e.g. a room 20 feet long, 15 feet wide, and 10 feet high. Fig. 475 repre-



sents one of these fireplaces. It differs from Teale's in the form of the bars, as the space exactly above the grating is left open instead of having a solid piece to hide the ashes.

An arrangement, which, in my opinion, is of superior merit, is shown in fig 476. This is **Shorland's Calorigen**. It consists merely of an iron box con-

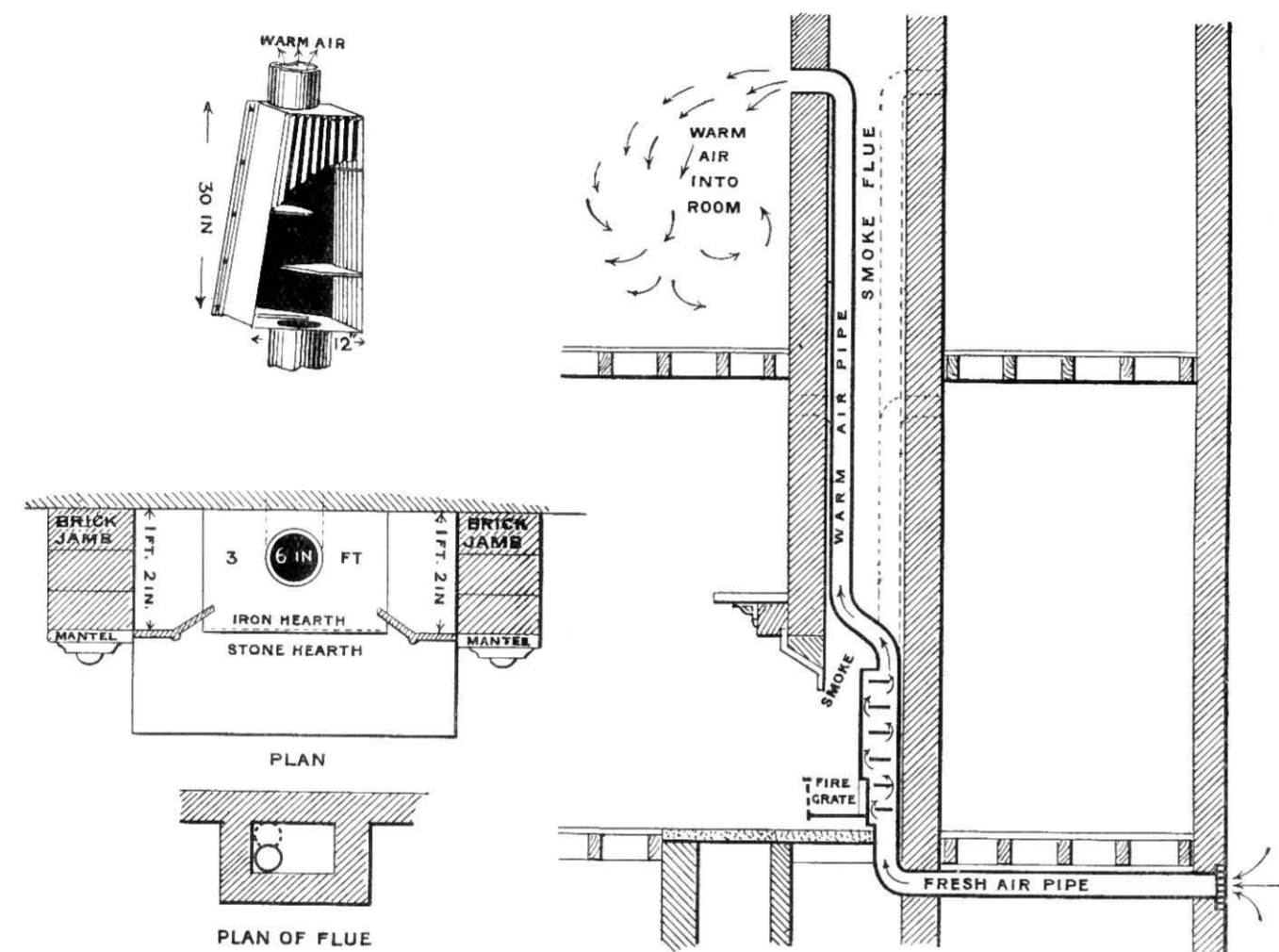

Fig. 476.—Shorland's Calorigen.

taining a series of baffle plates, which is fixed directly at the back of the fire, in a room on the floor below that of the room to be warmed. As the warm-air pipe is of metal, it readily receives heat from the smoke. I would suggest that, wherever it can be done, a case of some kind should be provided in front of the outside grid, in which muslin could be stretched to filter the air to some extent before it enters the room.<sup>1</sup>

The **smoke- nuisance** is undoubtedly due in a great measure to the imperfect combustion of fuel in household fires. Indeed, some authorities go so far as to say that houses are greater sinners in this respect than factories and workshops. Attention has already been drawn to certain grates in which the smoke is almost

<sup>1</sup> For some critical remarks on ventilating grates and stoves, see Chapter VIII., Section XII., Vol. II.—ED.

entirely consumed, and something will now be said concerning a process designed to prevent the emission of smoke. It may be assumed that, where open fires are used, it is quite impossible to prevent the production of smoke; the only question, then, is as to whether the emission of the smoke produced can be prevented. Colonel Dulier has succeeded in doing this to a very considerable extent. His apparatus has been in use for some time at the saw-mills belonging to the city of Glasgow, as well as in private houses. The apparatus is very simple. A jet of steam is inserted into the base of the smoke-flue, and the action of the steam upon the smoke facilitates the subsequent treatment, which consists of spraying water upon the smoke. The spray of water is emitted through very small holes in pipes placed inside the smoke-flue, and it has been proved by analyses, made by the City Analyst of Glasgow and by others, that about 94 per cent of the soot, and about half of the sulphurous acid, are in this way washed out of the smoke. This is, of course, a very satisfactory result, especially as the cost entailed in working the apparatus is little more than that of the water required for the purpose, and the action is practically automatic. A considerable part of the residue, obtained by drying the waste brought down by the water, is found to be unconsumed carbon, and this could of course be burnt, if it were found to be worth the trouble.<sup>1</sup>

<sup>1</sup> Nothing has yet been said about **kitchen-ranges**, and as these are rather appliances for cooking than for warming, the subject scarcely falls within the scope of this section. A few words may, however, be included concerning this important appliance. Kitchen-ranges fall into two broad classes, namely, *open* and *closed*. The two great disadvantages of open ranges are: (1) wastefulness of fuel, and (2) the large amount of radiant heat which renders the operation of cooking a very trying one; on the other hand, in houses where the kitchen-range is the only source of warmth to which the servants have access, the open fire has the merit of cheerfulness. Closed ranges are now made in an almost endless variety of sizes and patterns. Among the best is the well-known "Eagle" range, which has the great advantage of being complete in itself; ranges which depend for their successful working on the care and skill with which the flues are formed by the bricklayer, are not likely to be always successful. A new range possessing some important features has recently been designed; it is known as the "Fryston", and contains, in addition to the usual ovens, hot plates, pan-holes, &c., top and bottom flues to the ovens, with dampers so arranged that either the top or bottom heat, or both, can be shut off from either oven. This is rendered possible by the introduction of two fires, one above the other; by an ingenious arrangement one-half of the upper fire can be dropped to start the lower fire. The whole of the flues are of cast-iron, and form part of the range, as in the Eagle range already mentioned. One disadvantage of cast-iron flues must not be overlooked, namely, the liability of the iron to be burned through by the heat and smoke. The temperatures which can be obtained in the Fryston kitchener are extremely high; after exhaustive trials at the Exhibition held by the Sanitary Institute at Leeds in 1897, a medal was awarded to this range for its efficiency and economy.

A somewhat novel addition has recently been made to the kitchen-range in the shape of a chamber known as a **refuse-destroyer**, by means of which vegetable garbage can be burned without nuisance and without unduly interfering with the heat of the fire. It is shown in fig 476A, and is simply a chamber under the fire-grate in which the garbage is placed in order that it can be dried before being burned. In the words of the inventor, "A constant in-draught is ensured by means of holes in the door of the destructor, whereby the fumes are carried up through the fire, and thence into the chimney. This, with



the close and accurate fitting of the door, prevents the escape of any vapour or smell into the kitchen. . . . All greasy or fatty matter is effectually absorbed by the ash falling through the fire-bars, and when everything is reduced to a combustible condition, it is shovelled into the fire." This is undoubtedly a contrivance which merits favour, especially in large houses, where much vegetable refuse is produced. There

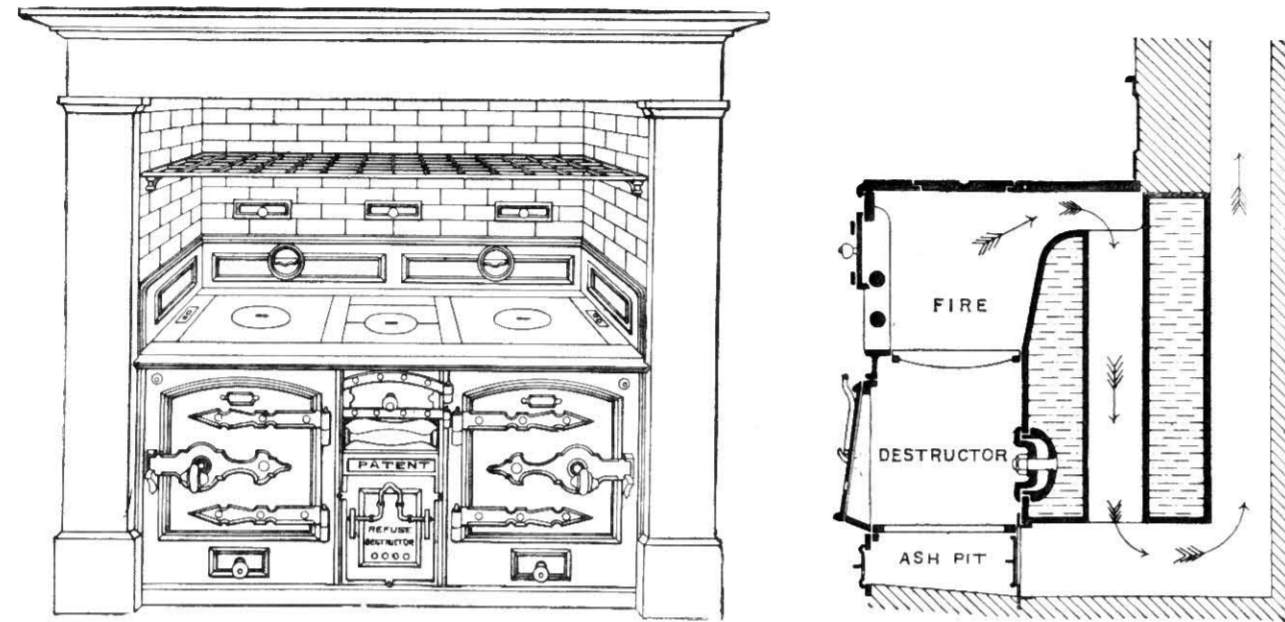

Fig. 476A. — View of Petter's Patent Refuse-destroyer, with enlarged Section through Destructor and Fire-grate.

is now no doubt that cremation is the most sanitary method of refuse-disposal, and if this apparatus were in use the contents of the ash-bin would never become objectionable.—Ed

### CHAPTER III.

#### GAS-STOVES AND OIL-STOVES.

##### 1. GAS-STOVES.

That the gas-stove is now so largely and so successfully used, is probably due more to Mr. Fletcher of Warrington than to anyone else. He made the subject of heating by gas a special study, and perfected the use of the atmospheric burner for this particular purpose. It seems a very simple matter to remove the coal from an ordinary fire-grate, attach a small casting provided with a number of holes and an atmospheric burner, and **fill the grate with asbestos balls**. This, however, is probably the most extravagant method of using gas for heating purposes. The grate is not designed for the purpose, and is much too deep to give the best results; it will probably require the addition of fire-brick inside at the back to diminish its area, and the register must be closed to a very considerable extent, or the chief part of the heat will be lost. If one of

the ordinary fittings is used, such as that shown in fig. 477, it will probably be found that, if the atmospheric burner be turned down, the gas will produce an unpleasant humming noise; this can only be obviated by either turning the gas partially off at the meter, and so throttling and reducing the pressure, or by using a special valve near the meter, such as Stott's Gas-regulator, set for the pressure most suitable for the stove. No atmospheric burner can be made absolutely silent, but if the stove is desired for use in the chamber of an invalid, special attention should be paid to the choice of the most silent burner possible.

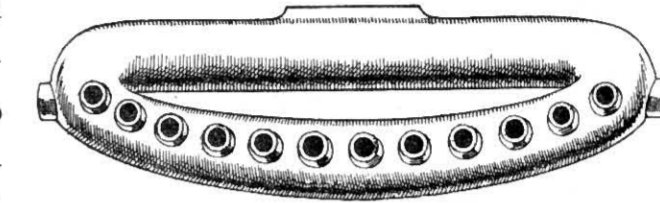

Fig. 477. — Burner for Asbestos-lump Fire in Ordinary Fire-grate.

Too much stress cannot be laid on **the necessity for a flue**. Wherever a gas-stove is used, the products of combustion must not be allowed to enter the room. A mere hole through the wall, with the flue of the stove put through it, is worse than useless, as the draught in such a case is always inwards.

**For economy in the consumption of gas** a special gas-stove must be used, and of these stoves there are a great number of patterns. If the greatest possible radiant heat be desired, with the appearance of an open fire, the iron fret front should be chosen; the flames of the burners play upon the thin iron, and speedily heat it to redness. The incandescent-ball fire comes next in radiating power. If, however, it be desired to turn the gas low, then a fibrous asbestos front should be used, as with this type the gas-supply may be lessened to a greater extent than with any other.

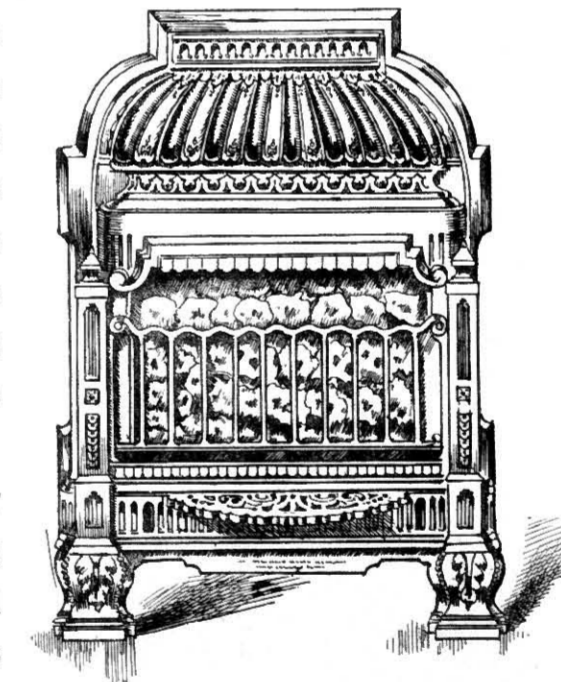

Fig. 478. — View of Gas-stove with Iron Fret Front.

Fig. 478 represents a stove suitable for placing in front of an ordinary register stove; it has **an iron fret front** 16 inches wide, and would be suitable for a bedroom about 20 feet square. The same kind of grate can be used with the ball-fuel, or with the fibrous asbestos.

**In order to get the greatest value from the heat** generated by the gas, it is desirable to pass the products of combustion around the inside of the grate before allowing them to escape to the flue. Such an arrangement is shown in fig. 479, which represents a gas-stove made by Messrs. Fletcher, Russell, & Co., Ltd. It will be seen that the waste gases pass up and down inside special



passages in the exterior casing before reaching the flue; the casing of the stove therefore gives off a great deal of heat. Such a stove requires a good flue, and a  $\frac{3}{8}$ -inch gas-pipe. It measures  $31\frac{1}{2}$  inches high,  $24\frac{1}{2}$  inches wide, and  $7\frac{1}{2}$  inches

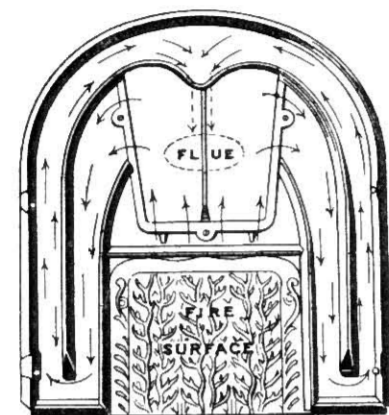

Fig. 479.—Section of Gas-stove with Flues for Utilizing the Waste Heat.

from back to front, and is calculated to warm rooms up to 20 feet square. Another form of stove by the same makers, of which a view and vertical section are given in fig. 480, is known as **Fletcher's Tubular Stove**, and gives both light and heat. The cold-air inlet may, if desired, be connected to a pipe carried through the external wall, or the stove may simply be placed in the room; in the latter case a circulation of the air in the room will be set up, the colder air passing in at the bottom, rising through the tubes, and coming out through the grating at the top. The flue must be connected to the chimney-flue, and it may be well to point out that in every case the inlet to the chimney-flue must be stopped by a plate, except where the stove-pipe passes through,

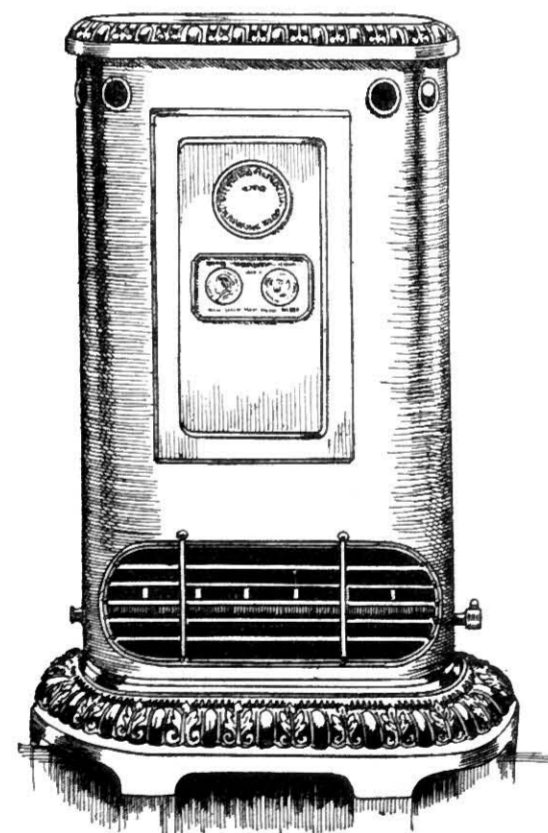

Fig. 480.—View and Vertical Section of Tubular Gas-stove.

otherwise the proper draught will not be obtained. My experience is that, with stoves of this type, it is essential to place a vessel of water on or near them, in order to moisten the air, otherwise it becomes unpleasantly dry. This type of stove is also made with the openings for the air in the front, the tubes being placed horizontally over the burners from front to back of the stove; the fresh air can be drawn from outside if desired.

The products of combustion of gas consist of water, carbonic acid gases (dioxide and monoxide), sulphur dioxide, and other gases, depending upon the impurities in the gas. Stoves are made which are called "**condensing stoves**", and which depend upon the cooling action of certain surfaces; the vapour of

water produced by the combustion is deposited in the form of drops upon these surfaces, and the water takes up the sulphur dioxide, forming sulphurous acid, and falls down into a special receptacle, which needs emptying frequently. The objectionable smell, usually emitted by a gas-stove unprovided with a flue, is done away with, but the invisible and injurious carbonic acid gases are unaffected and are therefore given off. For this reason, I consider that no gas-stove, whether of the condensing type or any other, should be used without a flue, if proper attention to health is given. The general public appear to believe that a "condensing stove" does away with *all* the products of combustion, but this is an entire delusion. It may, however, be considered that a condensing stove is of no greater detriment to the air of a room than the ordinary gas-burner, used without either special inlet-flue or outlet-flue for the air. This is of course true, but it must be remembered that a stove may consume a far larger quantity of gas than a number of burners; it is also upon the floor, and the heated carbonic acid gas rises easily to the breathing level, whereas, in the case of gas for illuminating purposes, the foul gases are often carried off through the ventilating outlets, which may be near the ceiling.

Another form of condensing stove, known as Clark's "**Syphon**" Hygienic Condensing Gas-stove, is illustrated in fig. 481. It consists of two Argand burners with the usual chimney tubes, and the particular type illustrated is stated to consume 16 feet of gas per hour, when turned full on, and to heat a room about 18 feet by 18 feet. Below the stove itself is the drip-tray, into which the water falls, as it is condensed. I cannot lay too much stress upon the fact that, although the greater part of the objectionable odour proceeding from the gas-stove without a flue is done away with, yet the large volume of carbonic acid gas is delivered into the room. This stove is intended to be used without a special flue, and some of the advantages claimed for it by the makers are that no flue is required, that no smoke, smell, or dirt, is produced. By the use of a water-vessel, the air can be rendered moist if desired. In passing, I may remark that it is especially desirable in a sick-room, where the patient is suffering from bronchitis, asthma, or other troubles of the respiratory organs, that the air should be moist, and it is usually better to make use of a wet blanket placed

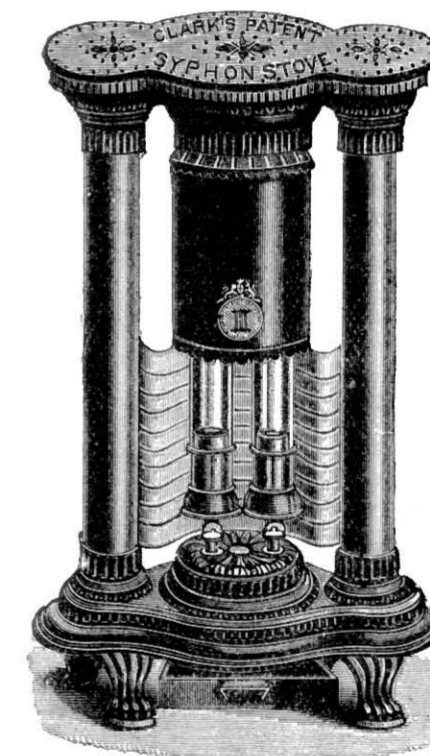

Fig. 481.—"Syphon" Condensing Gas-stove.



over a chair near the fire, than of a special kettle; the moisture will pass from the blanket readily in the form of vapour.

**Flat Stoves** have also been specially designed for use under floor-gratings,

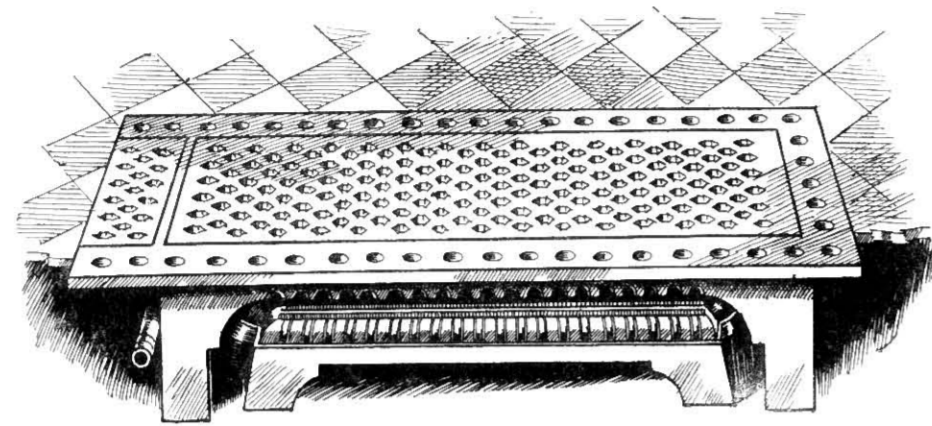

Fig. 482.—Flat Gas-stove for fixing under Floors.

and one of these is illustrated in fig. 482. The same remark applies to such stoves as to those already described, that, unless the products of combustion are carried away by a special flue, they will be found very objectionable.

## 2. OIL-STOVES.

Where gas cannot be had from a public supply, **oil-stoves are often useful**; but the price of oil has now risen so much higher than it was some years ago,



Fig. 483.—The "Emperor" Oil-stove.

that it will be found in most cases much more economical to use coal for permanent work, but where portability is an advantage, the oil-stove has many points in its favour. There are now several very satisfactory stoves upon the market, among which we may mention those known as Ripplingille's. The type of burner has recently been improved, and now the flat wick is used instead of the circular. In fig. 483 is shown a large type, known as the "Emperor". The oil-tank is of cast-iron in one piece, and is fitted with two 6-inch burners with patent extinguishers, in separate cylinders; the frames and radiators are of cast-iron, with large mica windows. The stoves are also made with very ornamental cast-iron cases. The same remarks apply to the use of oil-stoves as I

have already made with regard to gas-stoves, except that the sulphurous acid fumes are not present, but it is obvious that where so powerful a burner is used without a flue, the amount of carbonic acid gas given off must be very considerable.

A type of so-called **condensing-stove** is also made for burning oil, and, of course, the same method of adding moisture to the heated air can be adopted as was described in connection with the gas-stoves.

## CHAPTER IV.

### HEATING BY HOT OR WARMED AIR.

Before describing the various systems by which the dwelling-house may be heated by hot or warmed air, it may be well to say that to use this as the sole method of heating, to the exclusion of open fires, will not, in my opinion, commend itself to the average British householder. Rightly or wrongly, **we are so wedded to the system of open fires**, that their cheerful appearance would be greatly missed, and would hardly be compensated by even an equable warmth all over any given apartment. It would, moreover, be very difficult, and in some cases practically impossible, to apply such a system to an old house, although it could easily be arranged for in the design of a new one. There can be no doubt that the mere cost of fuel burnt would be less, if a system of heating by hot or warmed air were applied, instead of the usual system of open fires, but the difference in the cost of fuel on the two systems would not be sufficient in most cases to turn the scale in favour of the hot-air system.

In many parts of the continent of Europe, and in the United States and Canada, the winters are very much more severe, and the variations of temperature much greater, than in the British Isles, and in these cases it is found absolutely necessary to resort to means of heating more efficient than the ordinary open fire, and for this reason large close stoves, placed at some distance from the walls of the rooms, are frequently used; hot-air warming, however, has found wide acceptance in North America, though more, I believe, for public buildings, such as schools, than for private residences.

Before describing the various methods of heating buildings by means of warmed air, it will be well to allude to some of **the principal points which require attention**:—



(a) *Cleanliness of the air* is essential, and therefore, if the external air be loaded with soot and dust, it must be passed through some filtering material before being delivered into the living-rooms.

(b) *Freedom from disease-germs and noxious gases* is also essential; it is therefore necessary to choose the position of the inlet with careful attention to the position of gullies, ventilators to drains, and apparatus of a similar nature.

(c) *Humidity of the air* requires careful attention; the higher the temperature of the air, the more water-vapour it will hold in suspension. It is therefore obvious that, if relatively cold external air be heated and passed direct from the heating-apparatus into the living-rooms, it will be in the best condition for taking up moisture, and, while eminently fitted for use in the drying-closets of a laundry, it is very ill-adapted for breathing, and will necessarily cause the skin to feel parched, and the nose, mouth, and breathing-organs will be made dry and uncomfortable by the abstraction of their natural moisture. It is, therefore, very desirable that the air before delivery into the rooms should have imparted to it the proper humidity necessary to render it pleasant for breathing.

(d) *The requisite volume of air* must be passed in at such a velocity as to cause no perceptible draught, and it must then be extracted by a suitable flue of a height calculated to produce the requisite constant flow of air through the building.

(e) *The regulation of the temperature of the incoming air* must be provided for by a system of simple valves.

(f) *The air must not be heated too much*, otherwise the dust particles will be burnt, and a distinct and characteristic odour will be produced, which is very unpleasant.

In describing the Galton Stove and others of the same type, I have already stated that **dust and other matters** may be carried in with the incoming air. With a system in which the flow of air through the heating-apparatus, and thence through the house, is solely induced by the heated column of air in a flue, it is usually found impossible to obtain sufficient suction to permit of the use of a filtering-apparatus, and therefore recourse has to be had to some means of increasing the draught in the flue, either by the use of a fire at the bottom of it, by the use of a radiator in a similar position, or by mechanical means, such as a rotary-fan. In the Houses of Parliament, which are heated by carefully-humidified air, both fans and fires are used for causing the proper currents of air; but in the case of a house, it is desirable to avoid complication as much as possible, and I should deem the use of a rotary-fan to be undesirable except in a very large mansion.

If air be passed directly through the flue-tubes of an apparatus in which the products of combustion of the fuel play directly upon the tubes, there is always a risk that, by inattention on the part of the attendant, the surface of the tubes may become overheated; and then, instead of being warmed, **the incoming air will be burnt**. The results obtained depend entirely upon the temperature of the heating-surfaces, and upon the velocity of the air.

If the temperature in a living-room be examined at the floor-level, and at different heights above the floor, while artificial means of illumination are being used, it will

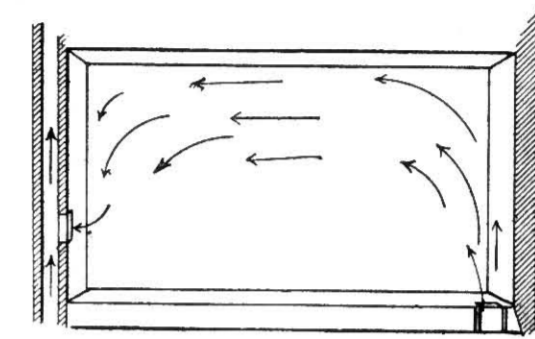

Fig. 486.

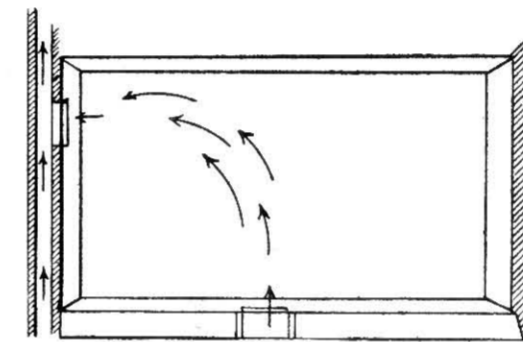

Fig. 484.

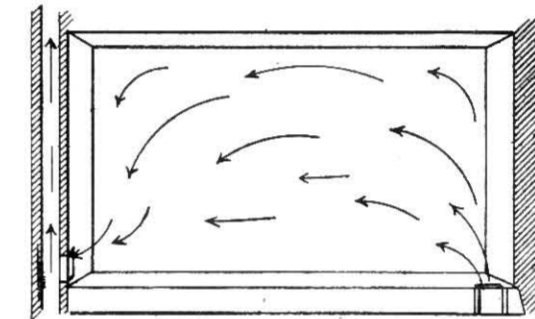

Fig. 487.

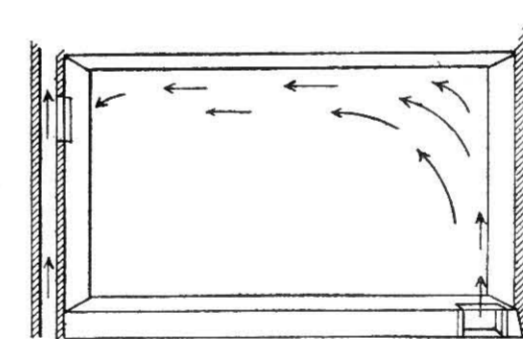

Fig. 485.

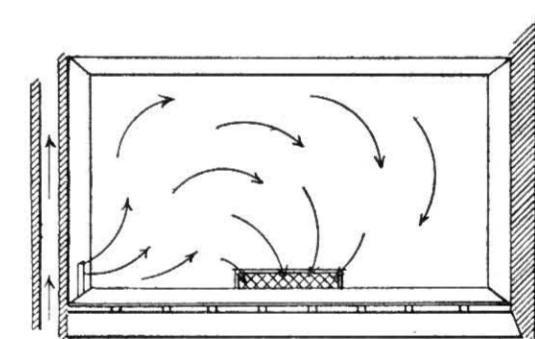

Fig. 488.

Figs. 484 to 488.—Various Arrangements for Entrance and Exit of Warmed Air.

be found that the air near the ceiling is extremely hot and much vitiated by the products of combustion of the gas, oil, or candles used for illumination, and also by the products of respiration. I am of course alluding to the usual arrangement where gas is burnt freely in the air, with no special flues for feeding the gas-jets with external air or getting rid of the products of combustion.

In the United States, **Smead's system of heating by hot air** has been very widely used in public schools and other buildings, and is stated to have given great satisfaction. Before describing this system, I shall borrow from Mr. Smead's work on the subject five illustrations (figs. 484 to 488), showing the results of various arrangements for the entrance and exit of the air. In fig. 484



the heated air enters through a grid, fixed in the middle of the floor, the result being that a column of heated air rises in the middle of the room and passes away near the ceiling, leaving a stagnant mass of cold foul air. The arrangement in fig. 485 is very similar. That in fig. 486 shows a slight improvement, while fig. 487 shows direct displacement of all the cold air by the warmed air,

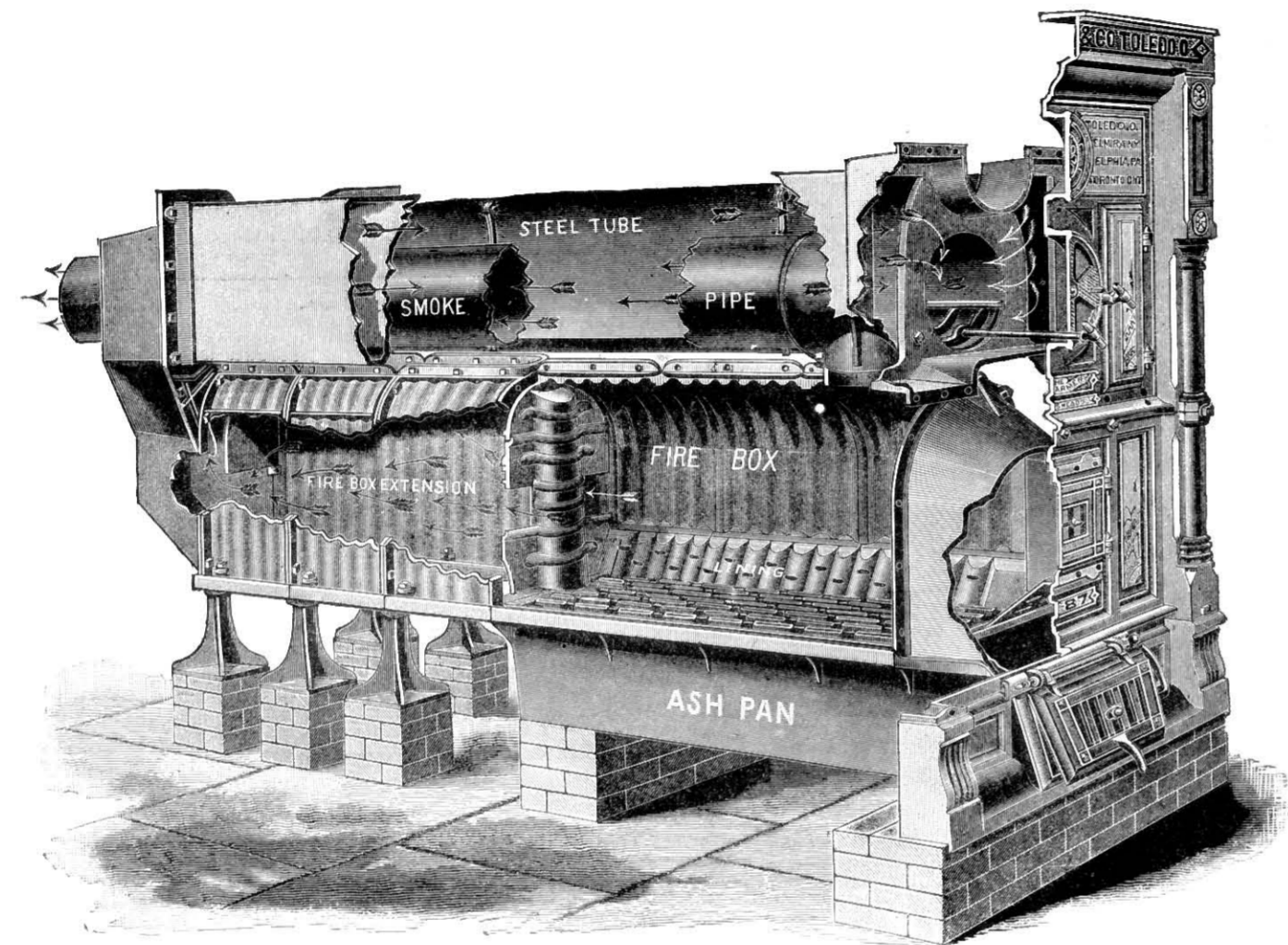

Fig. 489.—The "Smead" Furnace.

and fig. 488 shows an additional improvement by using a number of outlets at the floor-level, and then passing the foul air out between the floor of the room and the ceiling of the room below. It will be observed that no account is taken of the fact, that the products of combustion of the gas in the ordinary way would be taken down to the breathing-level.

In my opinion, there are several objections to the Smead system. One is that the products of respiration, and emanations from the body, which would naturally pass upwards (as they leave the body at a temperature of 98° Fahr.), are carried downwards in the current of air to the outlet near the floor, and the air thus vitiated must be breathed over again, which is undoubtedly a bad feature. The second objection is that, in order to keep a room warmed to

(say) 60° or 65° Fahr., the incoming air must necessarily be at a much higher temperature, probably about 120° Fahr. This current of heated air is most objectionable to any person standing or sitting near the inlet; but this latter objection is not confined to the Smead apparatus, but is common to all systems in which heated air is relied upon as the sole means of warming the rooms.

The Smead apparatus consists of a special type of air-heating furnace, and a system of inlet and outlet flues. The furnace is shown in fig. 489, which

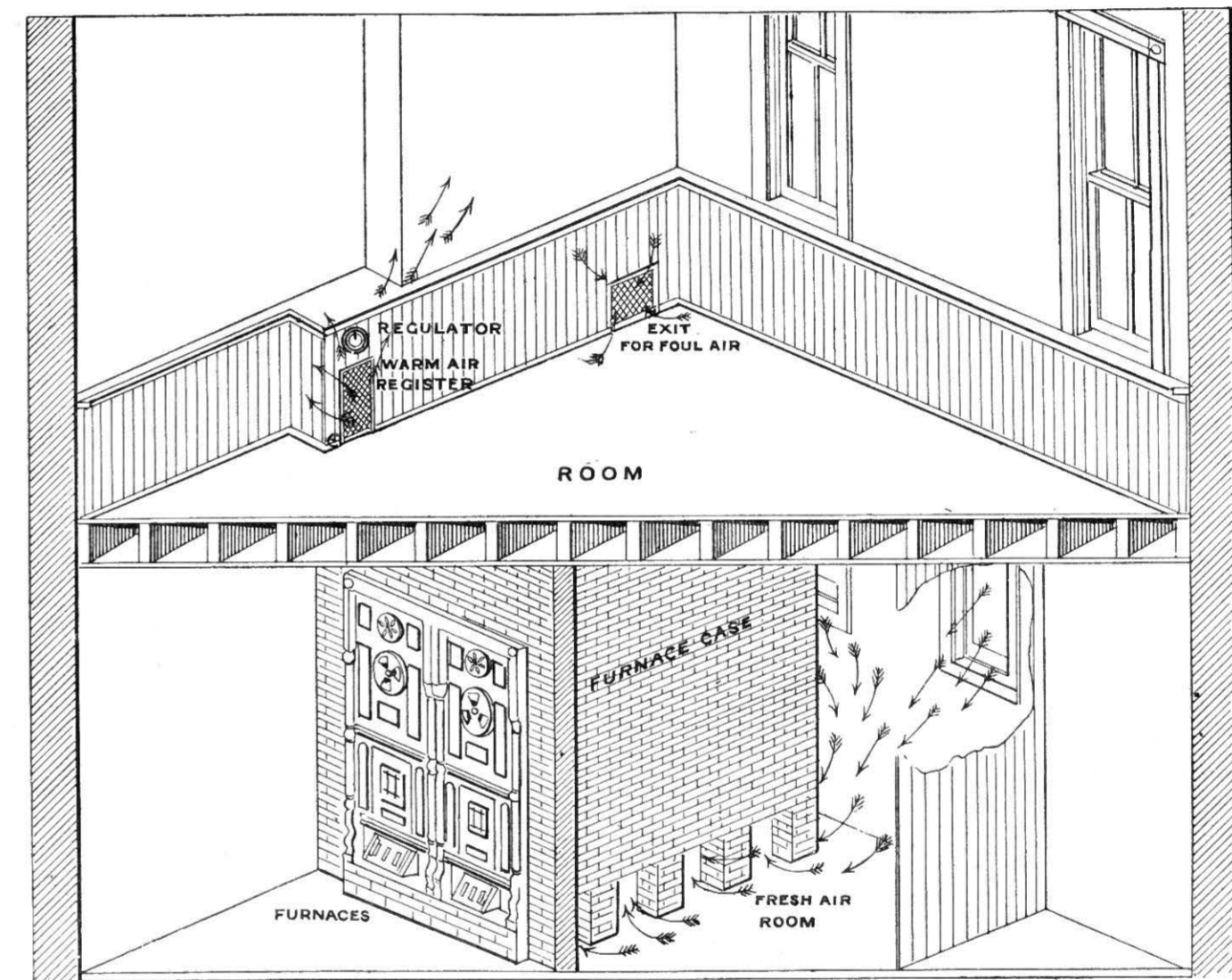

Fig. 490.—View of "Smead" Furnace set in Brickwork.

represents a type which has been gradually perfected from a much inferior form. The heater itself is inclosed in brick walls, which form a complete box round it, and it is placed as shown in the perspective view, fig. 490. The furnace is built in a special fresh-air room provided with large inlets from outside. The cold external air enters this room, and is drawn through the openings in the brickwork around the heater; it rises over the highly-heated iron surfaces of the heater, and then passes up the wall-flues to the different rooms. As a rule, one flue is arranged for each room, so that trouble may be avoided from baffling.



The system of inlets is very clearly shown in fig. 494, from which it will be observed that the inlet-flue is carried up a little above the floor-level, and is

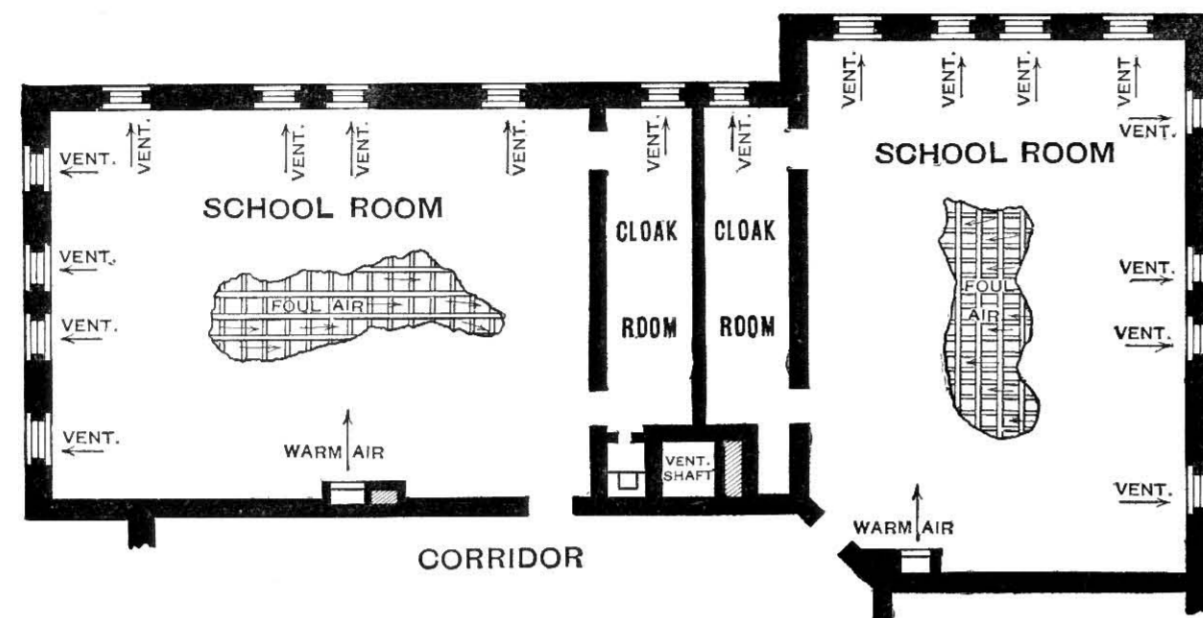

Fig. 491.—General Arrangement of Inlets and Outlets in the "Smead" System.

stopped there; the outlets are in each case close to the floor, in the wall opposite the inlet, as shown in fig. 491, and communicate with the upcast shaft. In

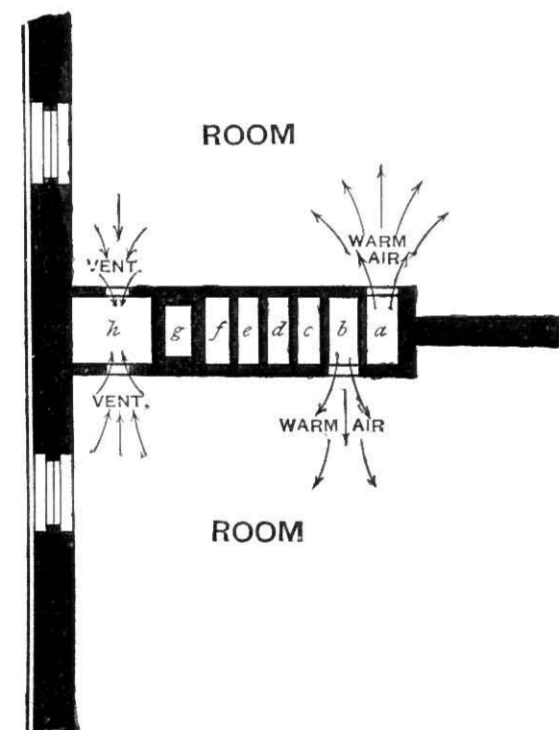

Fig. 492.—Plan showing Stack of Inlets and Outlets, "Smead" System.

*a, b*, warm air to first story; *c, d*, warm air to second story; *e, f*, warm air to third story; *g*, smoke flue; *h*, ventilating shaft.

plan the shafts are arranged as shown in fig. 492. The smoke-flue is next the ventilating shaft, so that the latter is kept constantly hot; they should be carried to a height above the roof of the building, sufficient to ensure freedom from the baffling caused by conflicting currents.

The arrangement for the regulation of heat is very ingenious. A view of the register and regulator, as seen from the interior of the room, is given in fig. 493. It will be seen that the register is designed to give the maximum amount of opening possible, and is of very ample size, so that the current of air entering may be of low velocity. Just above the register is placed the regulator, marked for warm air and cold air, and any desired mixture can be obtained by means of a very simple

and effective valve, which is shown in fig. 494.

It is quite obvious that if the Smead system of heating is to be applied

successfully to a building, that building must be originally designed for it. The system has been very largely used in the United States, and appears to have there given great satisfaction. A very elaborate work has been published by the Isaac D. Smead Company of Toledo, which is full of coloured plates. The book is well worthy of careful study. The system appears to be very economical in the consumption of fuel, and there can be no risk of explosion as is the case with the use of hot-water and steam plant. The incoming air is not, as a rule, washed or screened in any way, and is passed into the rooms at a temperature of about 120° Fahr. I am not aware that the air is humidified; no mention is made of this in the work alluded to. It is, however, obvious, that to heat air at even freezing-point up to 120° Fahr., without adding to it the requisite amount of moisture, must render the atmosphere in the rooms very dry, and in some cases this may be found objectionable. The mere heat of the incoming air will also probably be found uncomfortable to a person placed near the inlet, although it must always be borne in mind that air at such a temperature, or even higher, will rise in the vicinity of a close stove, and if the current of air passing over a hot-water or steam radiator be slow enough, the air may acquire a temperature considerably higher than that of the general body of air in the room.

The Heim System is the invention of Mr. H. Heim, an Austrian, and has been very largely adopted in Austria, Hungary, and other parts of Europe. The system consists of a central heating-apparatus, which is smoke-consuming, and is known as the Calorifer; this heats air brought from the exterior, and the heated air is delivered through specially-formed ducts or flues, prepared in the original design of the building. The same system may, however, be applied to portions of a building, or even to single rooms.

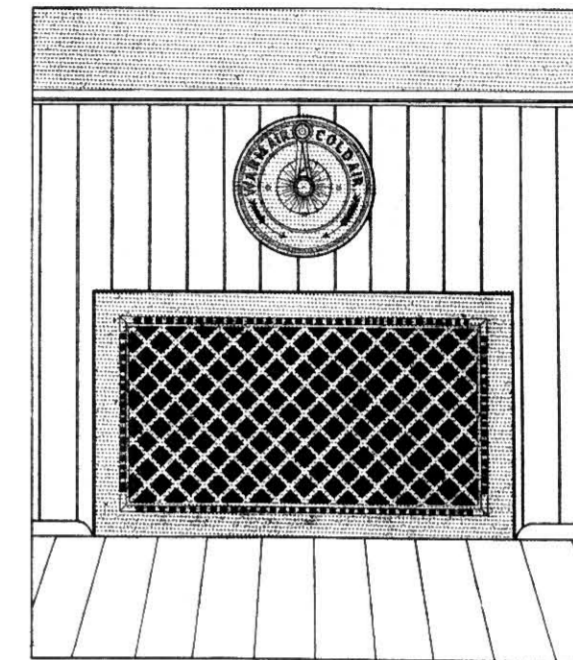

Fig. 493.—View of Register and Regulator.

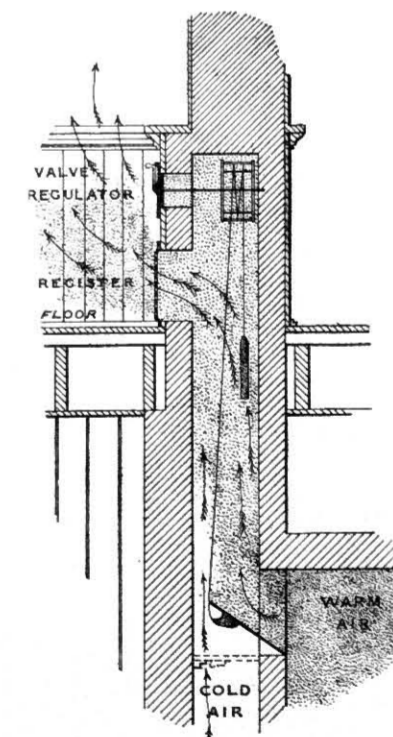

Fig. 494.—Section of Duct showing Valve for Incoming Air.



The arrangement of the Calorifer is shown in figs. 495 to 498. The channel D (figs. 495, 496, and 497) surrounds the grate, and is connected with the outer

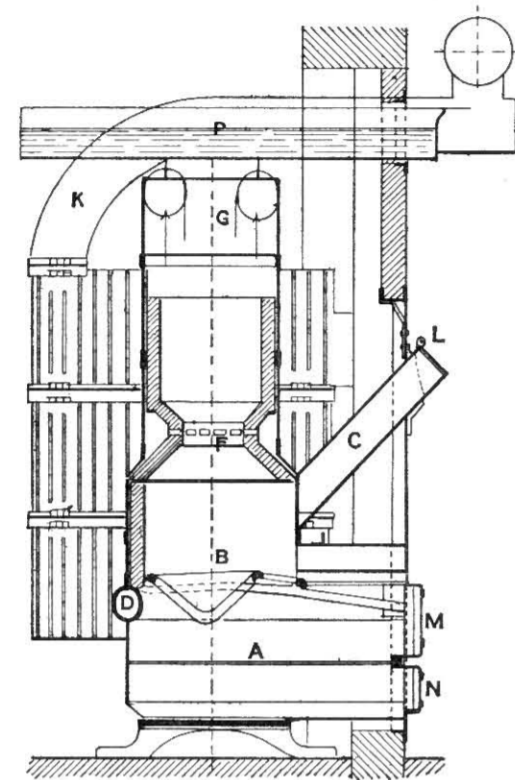

Fig. 495.—Vertical Section of Calorifer from Back to Front.

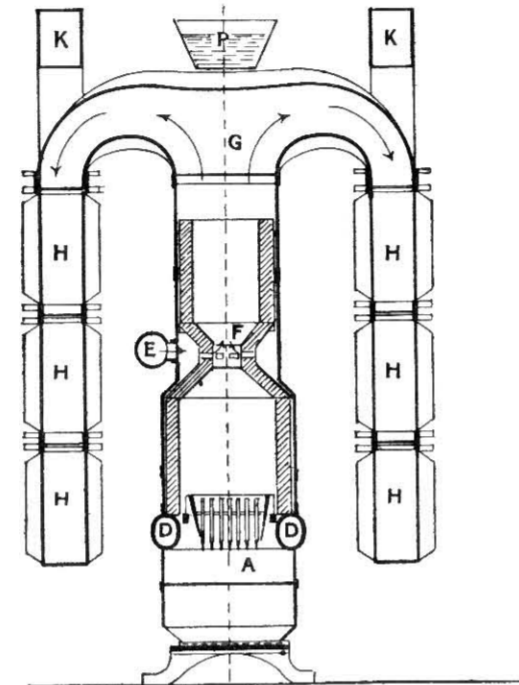

Fig. 496.—Vertical Section of Calorifer from Side to Side.

air, which is admitted and regulated by means of an adjustable valve. This channel introduces heated air under the grate, to ensure perfect combustion.

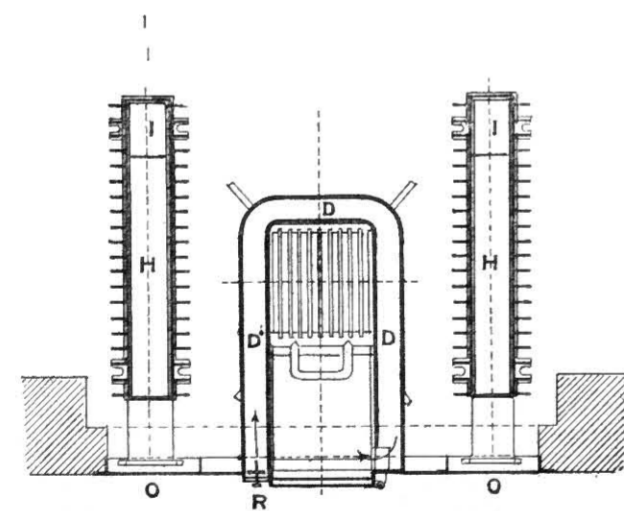

Fig. 497.—Plan of Calorifer.

The part of the filling and combustion chambers most exposed to the fire is lined with fire-bricks, which are cone-shaped towards the centre at F (figs. 495 and 496), so as to form, together with the cast-iron outer partitions, one channel, which is connected with the outer air similarly to the channel D. The action of this channel is likewise regulated by means of an adjustable valve. Through this channel highly-heated air is brought in contact with the products of combustion, ensuring a complete consumption of the smoke. Those parts of the combustion-chamber which are not lined with fire-bricks have smooth, ribbed, or fluted sides, according to the heating-surface required. On the uppermost casting of the combustion-chamber there are four nozzles, from

which the radiators H (fig. 496) are suspended freely, to allow for the expansion and contraction of all parts of the Calorifer, and so avoid the straining which causes loose joints and consequent leakage, so usual in other heating-apparatus. Through these radiators, which are also made smooth or ribbed according to the heating-surface required, the products of combustion are taken first downwards at H, and then upwards again through I (fig. 498), in such a way as to yield the greatest amount of warmth. The smoke-flues K (figs. 495, 496, and 498) are placed on the uppermost part of the radiators, and lead to the front of the heating-chamber, whence they are conducted to the chimney-flue. The doors L, M, and N serve for feeding the Calorifer, for cleaning out the grate, and for removing the ashes. They are made to be air-tight when closed, and remain closed whilst the apparatus is in action. The covers O (figs. 497 and 498) are for cleaning out the radiators. The warm air is kept sufficiently moist by an evaporating vessel P (figs. 495 and 496), which projects through the front partition above the Calorifer, and is provided with an indicator. The front of the apparatus is made of strong sheet-iron, and part of it can easily be removed for the purpose of cleaning the radiators, or for repairs. No brickwork has ever to be disturbed. The calorifers are made in various sizes, and their heating capacity is based upon the calculation of heating from 20° F. external temperature.

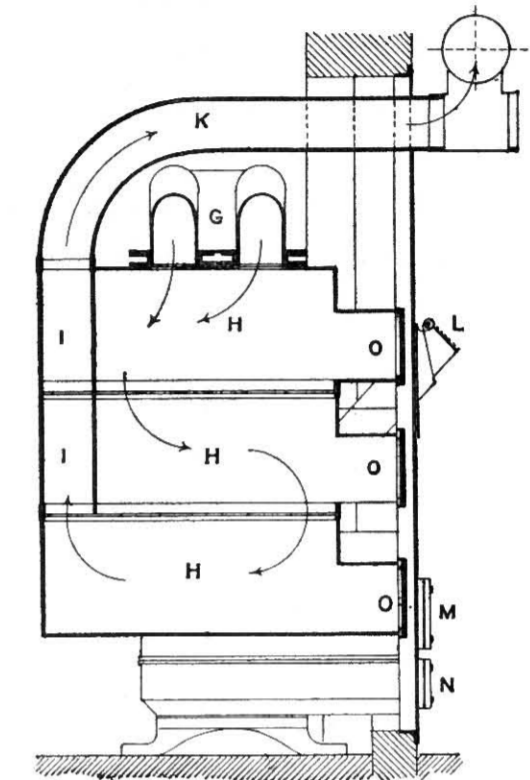

Fig. 498.—Vertical Section through Radiator of Calorifer.

This apparatus is intended to be set in a brick chamber, placed in direct communication with the external air. Some filtering material, such as muslin, can be stretched across the opening, and the heated air passes up the special flues, which must be provided in the building in the same way as for the Smead system. The Heim system differs, however, from that system in having the inlet at a height of about 6 feet above the floor, and in providing two outlet valves into a common flue, one valve being near the floor for winter use, and the other near the ceiling for summer use. A valve is provided in each inlet-flue, by means of which any desired mixture of cold and hot air can be obtained. It will be seen that here there is an attempt to humidify the air, which, I consider, should always be done. In the special pamphlet published by the



makers, reference is made to the fact that the Heim apparatus has been fitted in a number of Austrian royal castles. It is, in my opinion, very desirable (if the valves are only arranged to be either full open or quite shut) that some arrangement should be made for connecting the two outlet-valves together, so that one or other must always be open and the other shut; but if each valve can be regulated for partial or full opening, then that is obviously impossible, and the upper valve should be locked during the winter, and the lower one locked during the summer, otherwise both valves may be left open at the same time, when the ventilation will be imperfect and currents will be set up in various directions.

I have already described the Smead system, which is so well known in the United States, and also a characteristic continental system; it will now be of interest to see how **the same problem has been treated by a British engineer**, Mr. Key, and to note the radical differences between the systems. One of the objections raised to the Smead system by Drs. Drysdale and Hayward, and also by others, was that the direction of the currents of heated air in the rooms was such as to cause the vitiated air to be breathed over again. The objection has not perhaps much force when gas is not being burnt, for it is the practice of the Smead Company in the United States to change the air in school-rooms about six times per hour, and to provide from 1500 to 1800 cubic feet per head.

The Key system is what is known as **the plenum method of warming and ventilation**. The inventor early realized that the external air is so charged with soot, dust, and fog, that it is absolutely necessary to clean it thoroughly before it is admitted into a building; he also found that a dry cloth screen is of little use for the purpose, as it allows the particles to pass through it after a time, and becomes coated with dirt, which in itself may become a source of danger. He thus describes his system. "The air-supply for a building is drawn, by means of an air-propeller or fan, from a point where it is of undoubted purity, and furthest from any possibility of contamination. The entering air passes through an outer warming coil, and then through the air-filtering, air-washing, and humidifying screen. It is then warmed by coming into contact with coils, clustered in batteries within the air-warming chamber. The air passing through this chamber can be instantly reduced in temperature by admitting filtered cold air, through the by-pass doors provided for the purpose, the warm and cold air mixing while passing through the air-propeller. The air is then propelled into the main air-ducts, from which it passes into flues leading to each room. Secondary air-warming coils are placed at the base of each flue, so that the air

to each room may be warmed to any desired temperature while passing through them, and independently of the others.

"The volume of air admitted to each room is directed towards the ceiling, and can be regulated, or shut off altogether. It enters under a slight pressure, and is therefore continuously forcing out the air previously within the room. This may be done at a rate to renew the air of a room from 6 to 15 times per hour, and without experiencing [it is said] the slightest draught. The outgoing air passes off at the floor-level, and is led to roof ventilators, where the outlet air-valves are so constructed as to place the whole air within the building under a slight pressure of about four ounces per square foot in excess of the outside atmospheric pressure at the time. Whether there be no air movement outside, or whether it be blowing a gale, the outgoing air [we are told] flows in a continuous stream, unaffected by calms or gales."

**The apparatus for filtering and washing the air** consists of several thousand cords of suitable material, stretched from a beam near the ceiling to another near the floor of the air-chamber. When finished, the screen has the appearance of coarse cloth stretched across the apartment. The cords are placed so close that they touch each other; copper wires are laced through the vertical cords in horizontal rows, and being drawn tight, give the screen a flat surface. The rough fibrous nature of the material breaks up the entering air into very minute streams, which pass through equally all over its surface. These screens may, if desired, be formed double, in order to give an extra cleansing or scrubbing surface. The screen is kept moist by water trickling down each cord; and at regular intervals of more or less frequency, an automatic flushing-tank discharges a considerable volume of water down the screen, to remove loose matter which may have collected, and to thoroughly wet the whole surface.

Reference has already been made to the necessity for very careful attention to **the humidity of the air** used for warming, and it will be seen that the temperature of the incoming air, in this system, is first raised, then washed and humidified by the screen, and afterwards further heated by the local coils. It is warmed to a temperature of about 57° F. in passing through the primary air-warming chamber, and no portion of the air is raised above this temperature by contact with the heated coils. Either hot water or steam may be used in the pipes as the heating medium, but the inventor appears to prefer to use steam, as, of course, a somewhat smaller exposed surface will suffice, while at the same time none of the air is "burnt". One of the minor defects of the system appears to me to be the difficulty or impossibility of regulating the degree of humidity given to the air, as the quantity of water passing over the screen is practically constant.



With regard to the general system of **admitting the fresh air at the ceiling**, and discharging the foul air at the floor-level, it may be said that the wisdom of this course depends largely upon the method of illumination. If coal-gas is burnt for illumination in the ordinary way freely in the air, the heated products of combustion naturally rise to the ceiling, and should, in my opinion, be removed thence. Where the outlet-holes are at the floor-level, the products of combustion (including carbonic acid gas,  $\text{CO}_2$ ) must pass down and be breathed. For this reason, I am opposed to the downward system of warming and ventilation in such cases. Of course, if electric lighting be employed, no foul gases are produced by the lighting, and the objection would not hold; there is, however, a certain very small amount of heat produced by the lamps, which would have some little effect in producing or assisting upward currents of air.

Having now dealt with some of the methods adopted for passing warm air in large volumes into the rooms of buildings, as the sole means of warming and ventilation, I shall draw attention to a combined system, devised by Drs. Drysdale and Hayward, in which use is made of **warmed air in conjunction with open fires**. This system is described in their work entitled *Health and Comfort in House Building*. It is an axiom that change of air in a room is essential for health, and consequently that both an inlet and outlet for air must be provided; but no direct admission of cold external air into rooms should be tolerated. Moderately impure air, as pointed out by Dr. Inman, may not be so injurious as a draught of cold air. If the open fire is used, with a separate direct supply of fresh air from outside, this may, and in fact does, check the currents of cold air towards the fireplace, but rather diminishes the value of the ordinary chimney for ventilation. The fireplace should be studied with a view to economy of fuel, and not as a contrivance for the ventilation of rooms.

**Drs. Drysdale and Hayward** point out that no system of single-room ventilation and warming can be satisfactory, and that a general system is needed; they recommend the use of the kitchen fire as the means of causing the requisite suction, unless a special fire be set apart for the purpose. They also point out that the system of general diffusion of warmth throughout the house does not conduce to effeminate habits, or tend to induce a habit of avoiding exercise in the fresh air, but, on the contrary, is likely to diminish the tendency to bronchitis and quinsy. Supposing, say the authors, that we have provided for the ingress of a sufficient supply of moderately-warmed fresh air for all the wants of the house, and for a sufficient suction to draw off the vitiated air, the next point is to see that this heat is not wasted, and unless special care be taken in the original plan of the house, this waste will occur. As soon as the front door is

opened, the cold air from outside rushes in, and enters the hall, which, as a rule, passes between two sets of rooms direct to the main staircase, and the cold blast rushes through the whole house, tending to reduce it to the temperature of the outer air; the usual plan of an inner door is not always effective, as the outer door is often left open. The back door should open into the scullery or kitchen, or some other room where it is the interest of the servants to keep the door shut; the front door should open into a lobby or vestibule, to which the servants have separate access without going through the central hall of the house; and the windows, they say, should be made fast. The authors are no advocates of warming the house by heated air; all they recommend is the warming of the incoming air needed for ventilation, and this, unless the velocity is great, need not be heated above  $65^\circ$  F. for the comfortable supply of rooms otherwise warmed. It appears that Dr. Gordon Hogg had a house built at Chiswick, in which the authors' plans were carried out, except that no fires were used; within a year or two, however, fireplaces were added, and the windows made to open.<sup>1</sup>

Drs. Drysdale and Hayward consider that the best way of warming is by passing air over hot-water pipes, as this plan avoids burning the air. Two different houses are described. In house No. 1, there are no passages, and the incoming air is warmed by being passed over pipes heated by hot water at low pressure; in the case of the house No. 2, the same result is obtained by the use of small pipes with high-pressure hot water. The authors lay no stress upon the particular means adopted for warming the air, except that they consider that it should be done by surfaces at comparatively low temperature, and not by highly-heated surfaces as in a stove. The humidity of the air is a most important question, and it will not be satisfactory to merely heat the incoming air without paying any attention to its hygrometric condition. Air at  $66^\circ$  F. will hold about 6 grains of water suspended in each cubic foot, while air at  $30^\circ$  F. will only hold 2 grains of water in suspension. I have already pointed out the great objection to passing the air over highly-heated surfaces, as the contact burns and decomposes the particles of dust and organic matter, which are constantly present in the air, thus rendering it unpleasant for breathing.

The authors state that **the primary inlet for the air-supply** to the whole house should be in the basement, or perhaps it would be better to have such an inlet on each side of the building in order to be able to take advantage of the winds; or, to avoid dust and dirt, the inlet might consist of a flue carried up to a point above the roof, where it would be provided with an opening on each of

<sup>1</sup> Drawings of this house appear in Plates XX. and XXI., and a drawing of a somewhat similar house in Plate XXII. Further remarks on the system will be found at the end of Section XII.—Ed.



four sides. The incoming air may be screened, washed, cooled, or perfumed according to taste, but it must always be borne in mind that the screening and cleaning operations afford great obstruction to the passage of the air, and it is doubtful, in my opinion, whether the suction of the kitchen-flue would have been so successfully used by the authors, if they had resorted to any of these methods.

They say the best place for the furnace of the warming apparatus is the basement of the stairs lobby, and proceed to describe **the system as applied to the two houses** before alluded to, the kitchen fire alone being used as a means for creating the necessary suction. House No. 2 had a central corridor upon

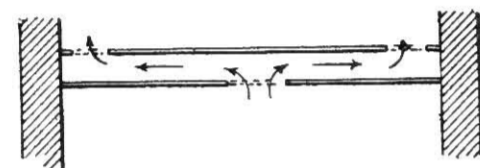

Fig. 499.—Section through Floor of Corridor, showing Passage of Heated Air.

each floor, and these were warmed in the following manner:—The warm air was first led into the ground-floor corridor, from which it passed up through a wide grating fixed in the middle of the ceiling; the air passed through between the ceiling and the floor above, and into the corridor above by a grating at each side running near the wall, as in fig. 499, thence it passed similarly to the corridor above. These corridors thus became sources of warmed

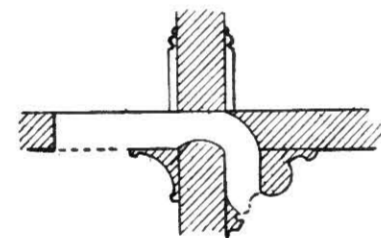

Fig. 500.—Section showing Air-inlet from Corridor to Room.

air, and the rooms on each side were fed from them by a series of holes, 7 inches long and 5 inches wide, formed in the cornice at the ceiling-level; the shape of the inlets is shown in section in fig. 500, and as many were used as could be got in the length of the rooms. The vitiated air was taken off by similar orifices in the cornice at the opposite side of the room, and it was found desirable to avoid the resistance entailed by causing the current to pass at right angles to its previous direction; to obtain the desired result, the orifices were formed with

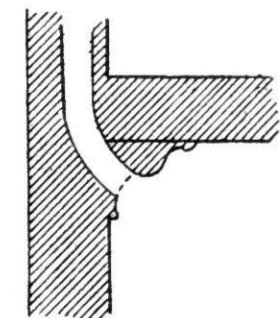

Fig. 501.—Section showing Air-outlet from Room.

an easy curve, as shown in fig. 501, the form approximating as nearly as possible to the Schiele curve. The fireplace should if possible be at the side of the room opposite to the inlet of air, and, if convenient, the lower member of the cornice should be hollow for its entire length, and the opening into the room be protected with an ornamental grating. The air is let into the rooms at about 65° F., and the authors remark that, when there are living beings in the room, their bodies are at 98° F., and the vitiated air ascends and the incoming warm air descends. Though carbonic acid gas is heavier than air at the same temperature, they consider that there is no danger of its settling near the floor, because

of its small proportion, and the speedy diffusion which takes place between gases.

The flues must of course be as smooth as possible inside, in order to afford the least obstruction to the passage of the air. Each room must be provided with a **separate outlet-flue**, and this must lead direct into a foul-air chamber at the top of the house; all the foul-air flues must come into this chamber at the same level. The foul-air chamber itself was in this case constructed of zinc, and was perfectly air-tight; from the base of this chamber descends the main foul-air flue, and this should go direct to the base of the kitchen-flues. All the passages should be so designed that the velocity of the air travelling along them should not exceed 150 to 200 feet per minute. The authors discuss various methods of creating the necessary suction to get rid of the foul air, but conclude that the kitchen-chimney is the best. The upcast foul-air flue must be separated from the back of the kitchen-fire by a sufficient thickness of fire-brick, and the smoke-flue should preferably be of iron, so that as much heat as possible should be given off to the foul-air flue. They propose that the kitchen smoke-flue should be fixed in the centre of the square foul-air upcast shaft, and that the top of the opening of the smoke-flue should be restricted to 9 inches diameter, which they consider ample, after carefully experimenting upon the subject. If, after trial, the heat evolved by the kitchen-fire is found inadequate, then a few coils of Perkins's hot-water pipes, or some jets of gas, might be added. They have, however, found that in houses of moderate size, the kitchen-fire suffices. The cross areas of the upcast shafts taken together should exceed the cross area of the downcast shaft, and there should be a special valve for regulating the size of the outlet for each room separately. From experiment upon the two houses already alluded to, the authors found that the velocity of air in the upcast shaft was about 400 feet per minute.

**In cases where the houses are already built**, it may be impossible to use the kitchen-flue as an upcast shaft; it would then be advisable to use gas-jets close to the outlets of each of the rooms, and probably a ring of gas-jets at the top in the foul-air chamber. While the problem of warming and ventilation may have been satisfactorily dealt with by the authors for special cases, it must always be remembered that the two houses referred to were specially designed for the system described, and such a system is not easily applicable to houses already built, with the front and back doors both possibly opening into the main hall or corridor, and both in direct communication with the central staircase.

In the country, the air is usually sufficiently clean to be admitted without filtration, but in towns it is so **loaded with soot and dust**, that some method of



cleansing it is eminently desirable. As soon, however, as filtration is resorted to, considerable resistance will have to be overcome, and I consider that in many cases it will be necessary to resort to the use of a ventilating fan, if certainty of action is to be secured, but such a fan is quite out of the question in a house of small or moderate size, unless an electric motor be used. The employment of electricity for the purpose would simplify the problem considerably, and would render unnecessary the use of the downcast and upcast flues. It is not desirable, however, to be dependent upon the action of such a fan for the warming and ventilation of an entire house.

---

## CHAPTER V.

### HEATING BY HOT WATER.

The subject of heating by hot water may be conveniently divided into two parts—*low-pressure heating* and *high-pressure heating*, which will be dealt with separately, as the arrangements of the various parts of the systems differ considerably. The low-pressure system has found by far the greatest favour in Great Britain, by reason of its greater safety and efficiency. The pipes are, however, larger than in the high-pressure system, and therefore the latter may sometimes be preferable. If the apparatus has been once properly installed, it should require very little attention, and an ordinary domestic servant, without any special training, can easily attend to the small amount of stoking required. The apparatus in either case will consist of a hot-water boiler, heated by a fire, gas, or oil, according to the magnitude of the work to be done, and a system of water-circulation pipes, either themselves giving off the heat, or connected with special groups of heating-surfaces known as radiators. Besides this, in the case of a low-pressure apparatus, a special feeding-cistern and pipe will be required, in order that the whole of the system may be kept full of water. In the high-pressure system, such an arrangement is not necessary.

In comparison with heating by open grates or stoves, the systems of heating by water possess the following advantages:—There is only one central fire to be attended to, and this is usually placed in the basement, entirely out of sight, at a point close to the fuel-store. In this way all dirt and dust from the use of coal and the removal of ashes are kept out of the house proper, or relegated to a place where their presence is not so objectionable. As the fuel

can be usually delivered close to the point where it is to be used, the annoyance and trouble caused by the filling of coal-scuttles, and the transport of coal through the living-rooms, are entirely avoided. The temperature of each room can be regulated to any desired degree, and ventilation can be effected quite as easily as by means of open fires. The radiating surfaces can be placed in the best possible position for giving the desired result, and can at the same time be made to counteract the evil effects of draughts produced by badly-fitting windows, &c. Equable warmth over a whole apartment can be obtained without difficulty. With the low-pressure system there is no danger to children, as they cannot possibly be seriously injured, even if they touch the radiating media, although, of course, it is preferable to protect these where very young children are constantly present. If the radiating surfaces are kept at a relatively low temperature, the passage of the incoming air over them will not deteriorate it, as may be the case where the air is passed over highly-heated surfaces, in contact with gases produced by burning fuel.

The position of radiators is a matter of some importance; they are usually placed in front of the windows, so that an upward current of warmed air may be produced, in the very place whence a cold draught usually proceeds. It is, however, preferable to form a special opening through the wall, directly under the window, and to place the radiator in a special case, through which the incoming air is taken. In this way, only warmed fresh air can enter the apartment, and the vitiated air must then be allowed to pass out by some specially-prepared openings. One of the objections to the use of radiators is that the current of warm air, ascending from the heating-surfaces, carries up with it particles of dust from the atmosphere, and from the floor of the room. After a time, this will cause a large black stain upon the wall. This is an additional reason for placing the radiators in front of the windows. In corridors and places of that kind, where such an arrangement is impossible, a shelf with a bracket at each end should be so arranged as to deflect the currents of heated air out from the wall.

One of the chief objections to hot-water warming-apparatus, is that the appearance of the radiators and pipes is not cheerful; and, in Great Britain at any rate, the cheerfulness of an open fire, though accompanied with inequalities of warming, is preferred before the more equable temperature obtained by the use of radiators.

There is no reason, however, why a combined system of open fires and hot-water heating should not be used. The flue of the fireplace might then be used as an outlet for the vitiated air, unless gas or oil is being burnt for the



illumination of the room, in which case I consider it desirable to form the outlets close to the ceiling. There are many instances where a hot-water system of comparatively small size and little cost, might be installed in a house, for the purpose of heating the bedrooms, hall, and corridors, while open fires might be retained as a means of heating the sitting-rooms on the ground-floor. With a very small expenditure of fuel, the sleeping apartments might then be kept at a temperature of 55 degrees during the night; and the labour of stoking would be very little, as special boilers are now made which will burn for twelve hours without attention.

### 1. THE LOW-PRESSURE SYSTEM.

The boiler is perhaps the most important feature in any installation, as upon it depends principally whether the system will be economical in the use of fuel, or very expensive.

The number of types and forms of hot-water boilers is very large, and almost every maker has some special design which he naturally considers superior to all others. In Great Britain, boilers are almost entirely made of wrought-iron or mild steel plates, welded into a solid vessel, but in the United States they are very frequently made of cast-iron. This material, however, is not by any means equal to the others, as it is liable to crack when heated, and thus perhaps let loose a flood of boiling water in the basement of the building.

In boilers which are to be used solely for purposes of heating, it is not so necessary to provide ample facilities for removing incrustation as in boilers for the supply of hot-water for domestic purposes. A system of hot-water heating consumes practically no water, it being only requisite to allow a supply of a few pints per week to replace the losses produced by evaporation in the expansion tank. The same water circulates constantly, and, having once deposited its impurities, can cause no further trouble with incrustation, while, in the case of a boiler used for hot-water service, the deposit goes on gradually accumulating in the whole of the interior of the apparatus.

It is always desirable, on the score of economy of fuel, to set the boiler in brickwork, as the loss of heat by radiation is far less than when the metal exterior of the boiler is exposed to the air. Of course it costs more to build a brick setting than to merely place the boiler on the floor, and for small installations, where first cost is the most important item, it may be advisable to employ a boiler without setting.

Boilers heated by gas are made for use in connection with low-pressure hot-

water apparatus, and will prove useful for small installations. A good boiler of this kind is shown in fig. 502. It has the disadvantage of being made of cast-iron. The cross tubes are cast with the inner body. This boiler is made in two sizes, the smaller being 19½ inches high and 13½ inches from back to front, while the larger is 31 inches high and 17 inches from back to front. The former is said to heat, as a maximum, 40 feet of 4-inch pipe, and the latter 100 feet. The connections are 1 inch and 1½ inches respectively.

Where the amount of pipe to be heated is small, an independent boiler of the form

illustrated in fig. 503 may be used; this is specially designed so that a large amount of fuel may be fed into it at one time, and the inner part is made conical to prevent the fuel from sticking. Such a boiler would have one 2-inch flow-pipe and one 2-inch return, and would be made of wrought-iron plates welded together. If 4 feet high and 15 inches in diameter, a boiler of this kind will heat about 130 square feet of radiating surface,<sup>1</sup> while one 6 feet high and 24 inches in diameter is estimated to heat about 450 square feet. For a larger installation, such a boiler as the "Marlor", shown in fig. 504, may be used; it

<sup>1</sup> By "radiating surface" is meant the uncovered external surface of the pipes, radiators, coils, &c., connected with the boiler. Those parts of the system which are not required to radiate heat should be carefully protected with some non-conducting covering.

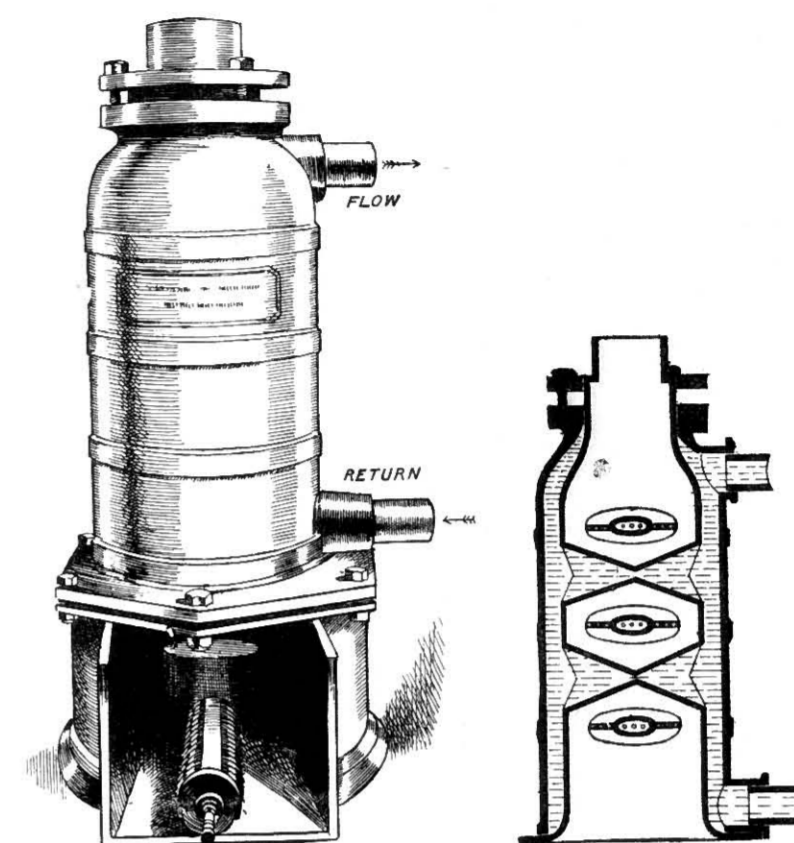

Fig. 502.—View and Section of Fletcher, Russell, & Co.'s Cross-tube Gas Boiler.

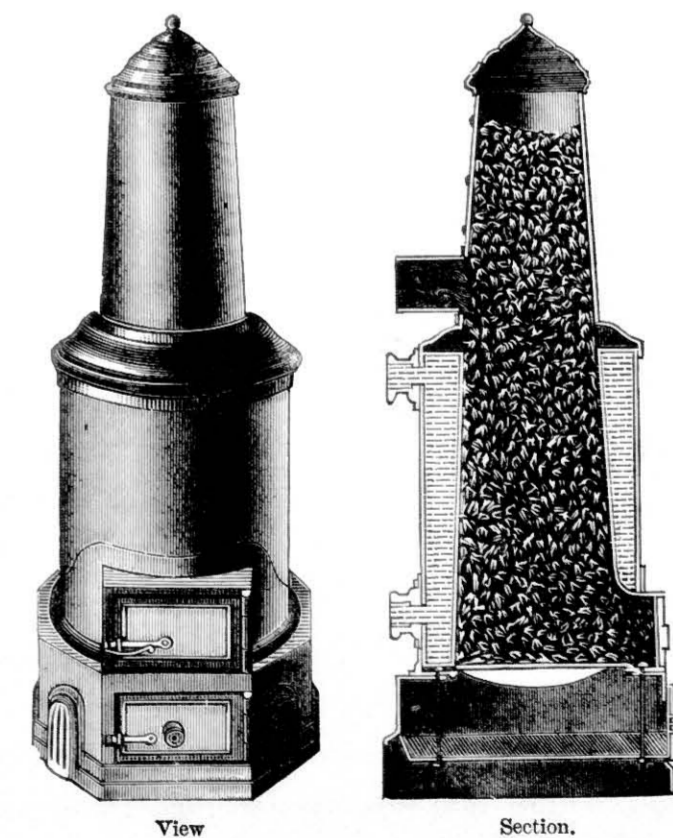

Fig. 503.—View and Section of Independent Conical Boiler.



is made of  $\frac{3}{8}$ -inch mild steel plates, in various sizes up to 6 feet high and 4 feet in diameter, this size being supposed to heat 2500 square feet of pipe-surface.

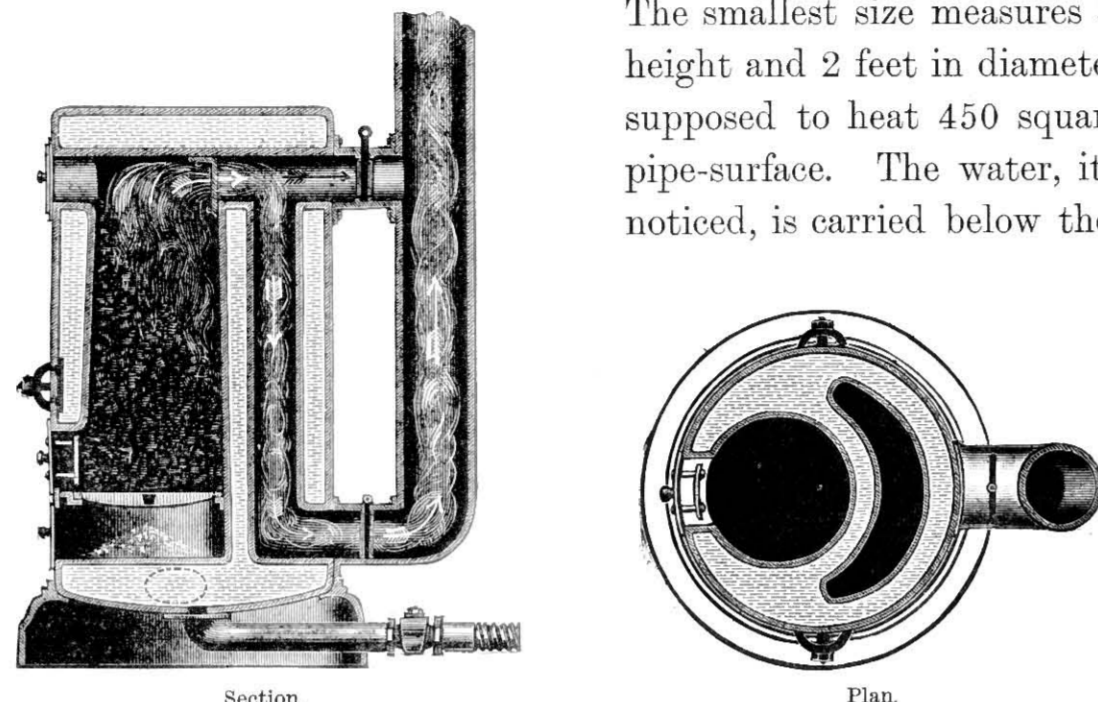

Fig. 504.—Plan and Section of the "Marlor" Boiler.

The smallest size measures 3 feet in height and 2 feet in diameter, and is supposed to heat 450 square feet of pipe-surface. The water, it will be noticed, is carried below the level of

the ash-pan, so that there is a quiet place in which sediment may easily collect, and this can be flushed out at intervals. Such a boiler is, however, somewhat

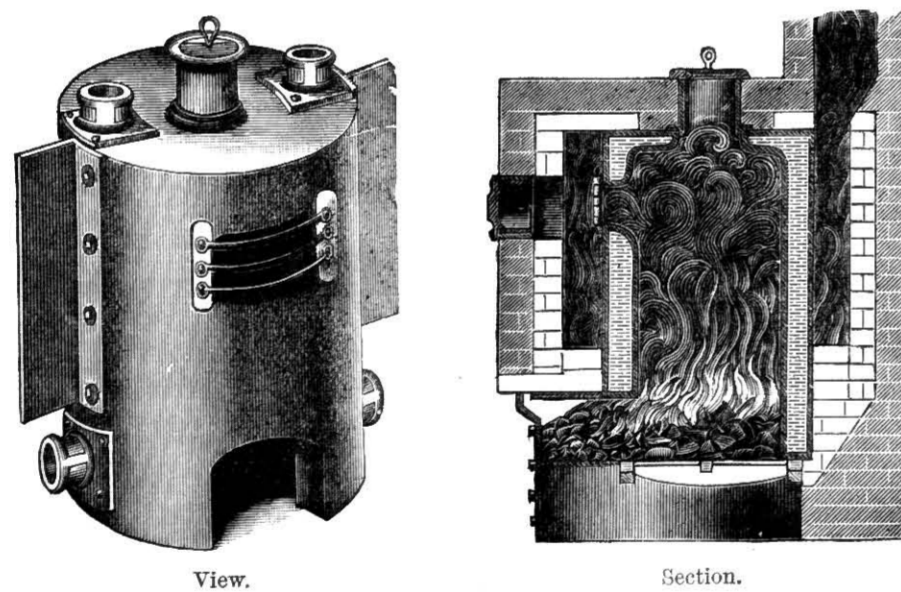

Fig. 505.—View and Section of the "Excelsior" Boiler.

expensive when compared with the types already referred to.

For larger works, it is best to use a type of boiler in brick setting, as much greater economy can thus be obtained. The boiler illustrated in fig. 505 is known as the "Excelsior" Boiler, and consists of an external cylinder of wrought iron,

into which is welded an inner cylinder of Siemens mild-steel plate. The metal is  $\frac{5}{16}$  inch thick, or, for better work,  $\frac{3}{8}$ -inch. The water-space is brought down to the level of the grate-bar, and the fuel is filled-in through the top hole, and falls on to the grate-bars; the products of combustion rise and fill the inner chamber, then pass out at the front opening (which is protected by cross bars) into the space between the boiler and the brickwork, travel half-way round in

each direction until they strike the baffle-plates, under which they pass, and then proceed round the back of the boiler to the flue. It will thus be seen that the products of combustion surround the water-chamber on all sides. In the illustrations, two connections are shown at the top for the flow-pipes, and two inlets at the bottom for the returns. Such a boiler, measuring 24 inches in height by 18 inches in diameter outside, is capable of heating about 350 square

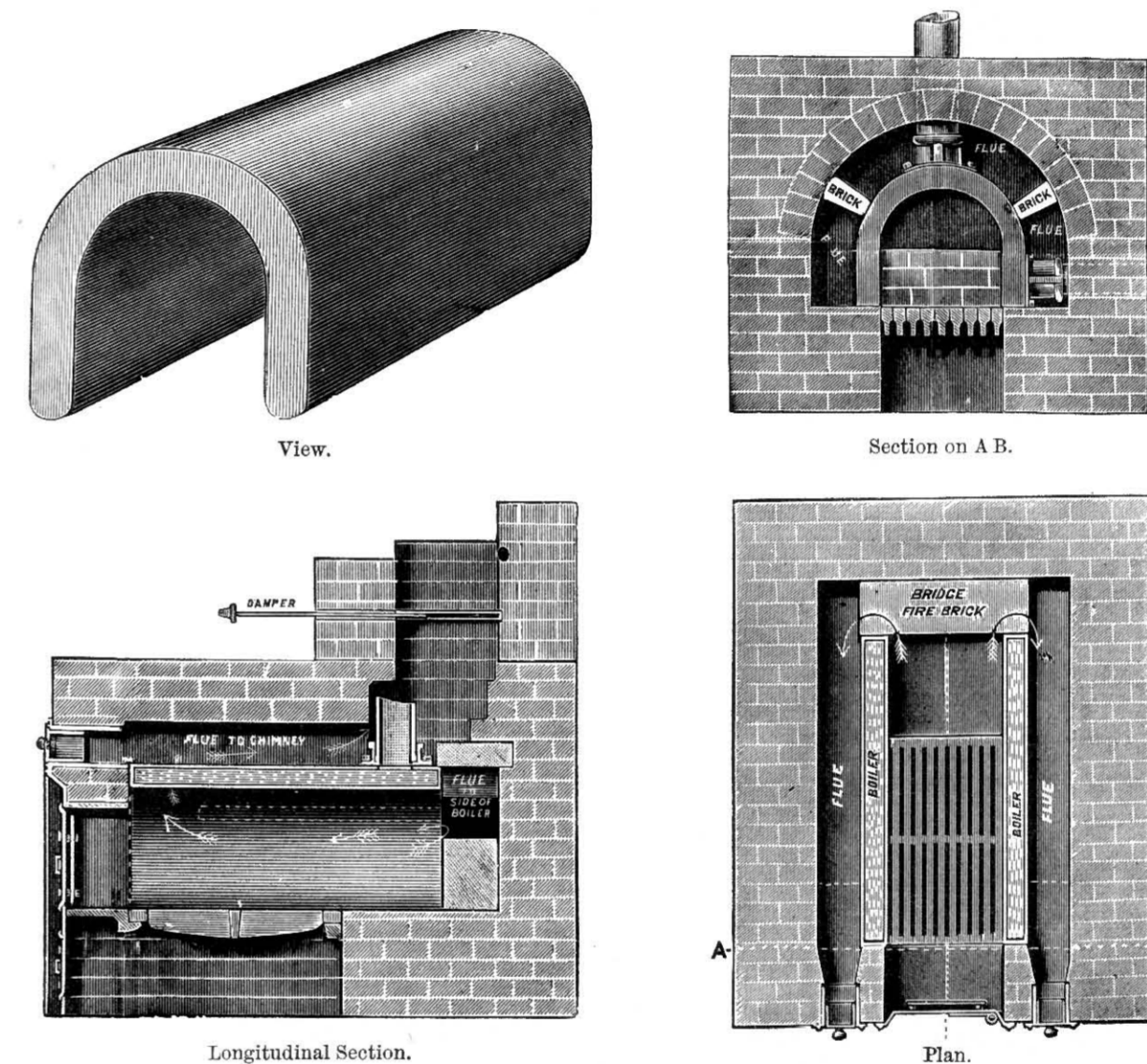

Fig. 506.—Plan, View, and Sections of Simple Saddle Boiler.

feet of radiating surface, while a boiler 36 inches high by 26 inches in diameter will heat about 825 square feet of radiating surface.

The boiler which has found the greatest favour—owing to its very simple form—is the plain saddle boiler, shown in fig. 506. This is made of welded wrought-iron plate,  $\frac{5}{16}$  or  $\frac{3}{8}$  inch thick, and is so set that the products of combustion play all over its inner and outer surfaces. The plan and sections of the setting show very clearly how this is accomplished. The flames play upon the inner part of the boiler, and the gases then pass to the back, return by the sides



to the front, and pass over the top of the boiler to the flue. The flues on the top of the boiler are not of much use as heating-surfaces, but the heat is radiated

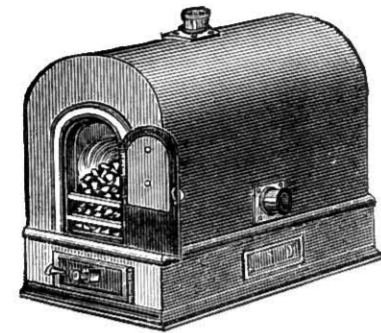

View.  
Fig. 507.—View and Section of Independent Saddle Boiler.

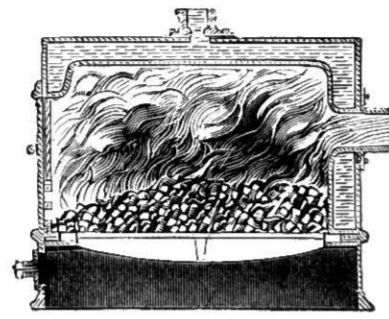

Section.

off the brick arch; the side flues are of much the greatest efficiency. If coal be burnt in a boiler of this class, the flues should be constantly swept out to maintain the boiler in its highest efficiency. Such a boiler, 48 inches long, by

22 inches by 19 inches over all, is expected to heat about 640 square feet of radiating surface. Saddle boilers can be obtained of smaller size, made in the independent form, that is, to be used without brick setting, as shown in fig. 507. This cannot, of course, be so economical as the others, as the whole of the exterior of the boiler is exposed to the air, and the flames pass direct to the flue. The loss of heat from the exterior could be diminished by coating the boiler with non-conducting composition. The saddle boiler may be made as

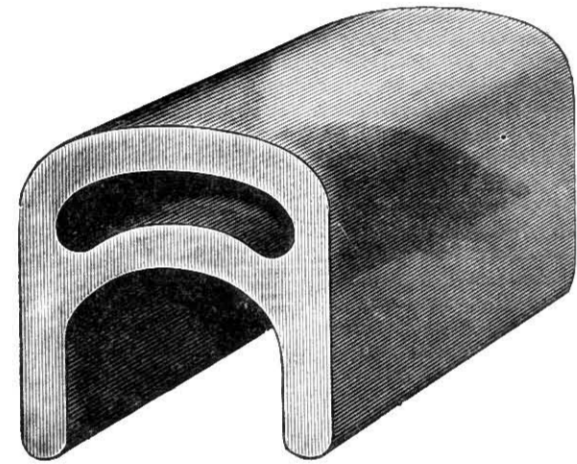
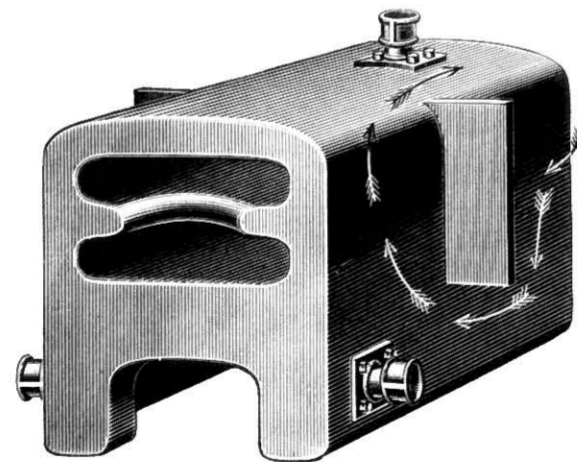
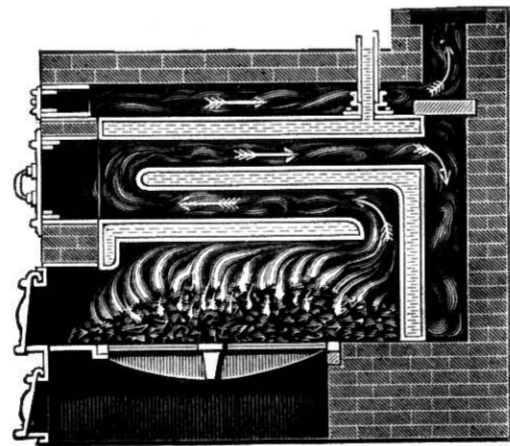

Fig. 508.—View of the "Devona" Saddle Boiler.

shown in fig. 508; the return-flue then passes back inside the boiler, and there-



View.



Section.

Fig. 509.—View and Section of the "Edina" Boiler.

fore more use is made of the waste gases. The cost of such a boiler is, however, higher.

The boiler illustrated in fig. 509 is a comparatively new design, in which the

products of combustion are passed round a great many times before finally reaching the flue. Economy in fuel is obtained, but the first cost of the apparatus is considerably greater than that of a boiler of the plain saddle form.

Although wrought-iron boilers are more largely used in this country than cast-iron boilers, it will not do to overlook the latter. The Gurney Foundry

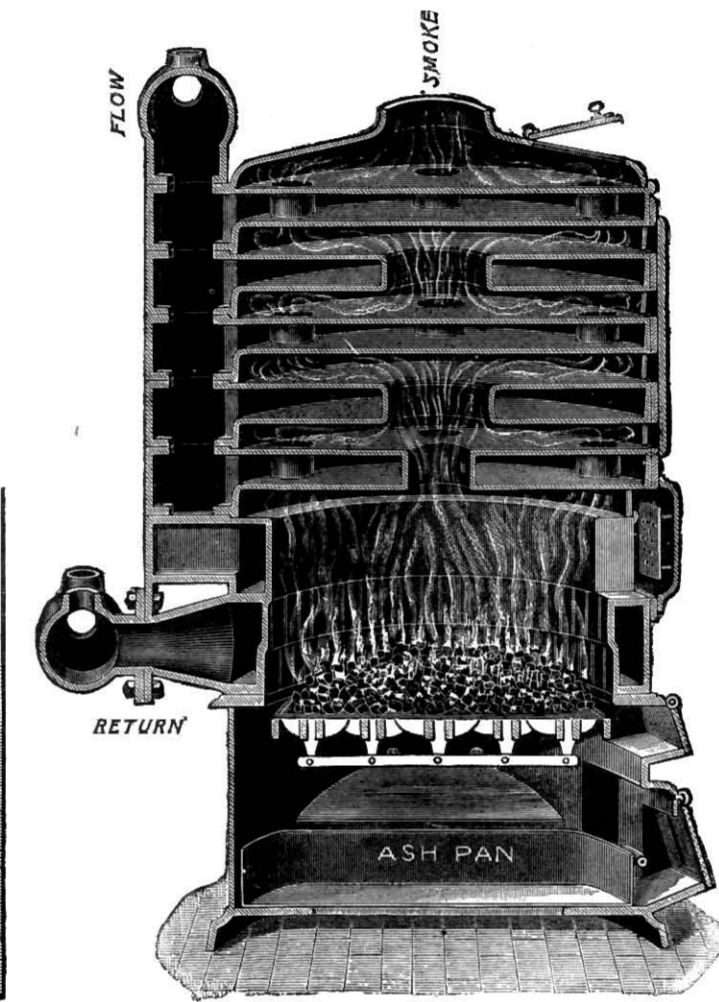
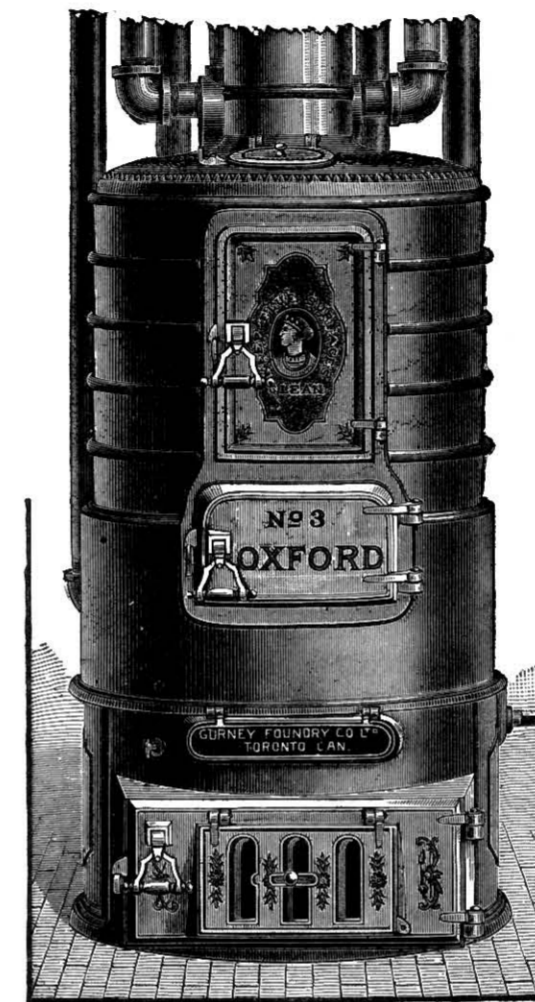

Fig. 510.—View and Vertical Section of the "Oxford" Cast-iron Boiler.

Co., Ltd., of Toronto, Canada, make two types of boiler, which have found acceptance in Canada, the United States, and even in this country. The larger type is known as the "Oxford". A view and section of it are given in fig. 510, and the separate portions of which the apparatus is built in figs. 511 and 512. This "heater" is built upon the theory of directed circulation: thus, the water entering at the return heater (which is on the level of the fire-pot instead of in the ash-base) is passed to the front of the fire-pot at the bottom, and over a diaphragm which runs through the water-chamber of the fire-pot, and then back to a point above the point of entry. It is there conducted into the first section above the fire, through two openings, which run continuously from the fire-pot to the top section of the heater. These two side openings deliver



the water on the respective sides of each section of the heater to a chamber which runs to the centre, to a directing diaphragm, and the two streams are thence thrown back again to a central opening, which is open to the top of the heater, and upon which the flow-heater is placed. The circulation in each of



Fig. 511.—View of two Rings of the "Oxford" Boiler, showing circulation of water and back connection.

these sections is independent of the other. The theory of this circulation is, that, while there is no doubt that a directed current over a warm plate is only heated on its outer edges, the agitation and interior circulation in the liquid itself present many surfaces during the time the liquid is passing over the heated surface. In Canada and in the United States a number of heaters are dependent upon this circulation, and its success is now beyond question.

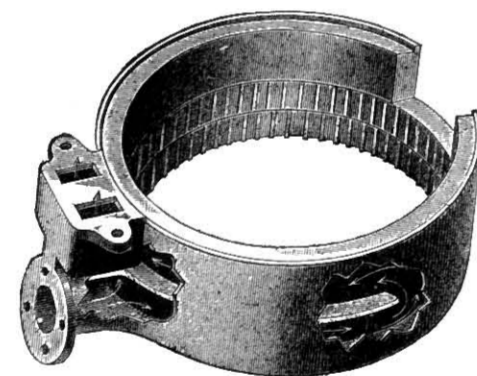

Fig. 512.—View of Fire-pot of the "Oxford" Boiler, showing circulation of water.

The ash-base of this heater is provided with an ash-pan, the convenience of which will at once appear. In connection with the fire-pot, the makers draw attention to "a very ingenious contrivance, by which a most perfect combustion is secured, without the use of non-conducting material between the fire and water-surfaces.

This is by the use of broken lines, both horizontal and vertical. The horizontal lines are secured by the surface being larger at the grate than just above, there being three distinct steps. These several steps are crossed by broken vertical ribs, which secure the most perfect results. . . . The products of combustion are passed through oval holes 'staggered', until the final delivery to a warm chamber at the top of the heater, and so finally to the exit-flue."

At first sight the heater seems somewhat complicated, but it appears to give extremely good results. There will, of course, be loss of heat from the exterior,

and this cannot well be counteracted by the application of non-conducting composition, as it would interfere with the joints. A boiler of this kind, measuring  $42\frac{1}{2}$  inches in height and 22 inches in diameter, is rated to be capable of heating about 170 square feet of radiating surface, and as this is the rating used in Canada, it is considered well within the mark for the much more temperate climate of the British Isles.

The **Defiance Boiler**, by the same makers, is intended for small powers, and is shown in fig. 513.

The boilers made by Mr. James Keith are also of cast-iron. The type known as the "**Viaduct**" Boiler is illustrated in fig. 514. These require no brick-setting whatever, the cast-iron exterior has a fire-brick lining, which is, in my opinion, a distinct advantage over the Canadian form, as the heat will be radiated from the glowing surface, and it is practically impossible for the exterior of the heater to become red-hot, as may easily happen in the case of the Canadian type. The shell is made in two pieces, which are held together by bolts. The stoking-door is immediately under the crown of the arched water-way, and consequently a large amount of fuel can be inserted, and the fire will burn for a long time without attention. A clinker-door is provided immediately over the grate-bars, and an ash-door below. There are in the figure two outlets for the flow-pipes, and two inlets for the returns. This type is made in sizes with heating capacities up to 1500 square feet of radiating surface.

The surface required in an ordinary house will not usually exceed this figure, but if it does, another more powerful boiler by the same maker may be used; it is known as the "**Challenge**" Boiler, and is illustrated in fig. 515. This boiler has horizontal or nearly horizontal sections, somewhat similar to the Gurney boiler, but, instead of horizontal baffle-plates, cross tubes run from back to front. It does not appear to me to be designed so as to baffle the upward currents of heated gases as effectually as the Canadian type, but the deposition of soot upon horizontal surfaces must always be very considerable, even when the boiler is

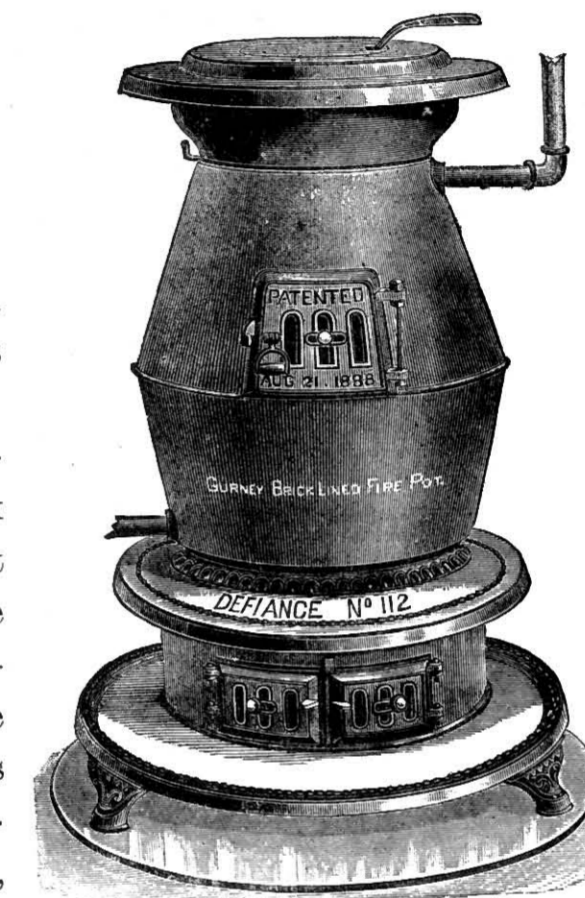

Fig. 513.—View of the "Defiance" Cast-iron Boiler.



cleaned out frequently, and this would detract from the value of the Gurney Boiler.

An interesting type of boiler, resembling the boilers used for high-pressure hot-water heating, is made by Messrs. Renton Gibbs & Co., Ltd., and is

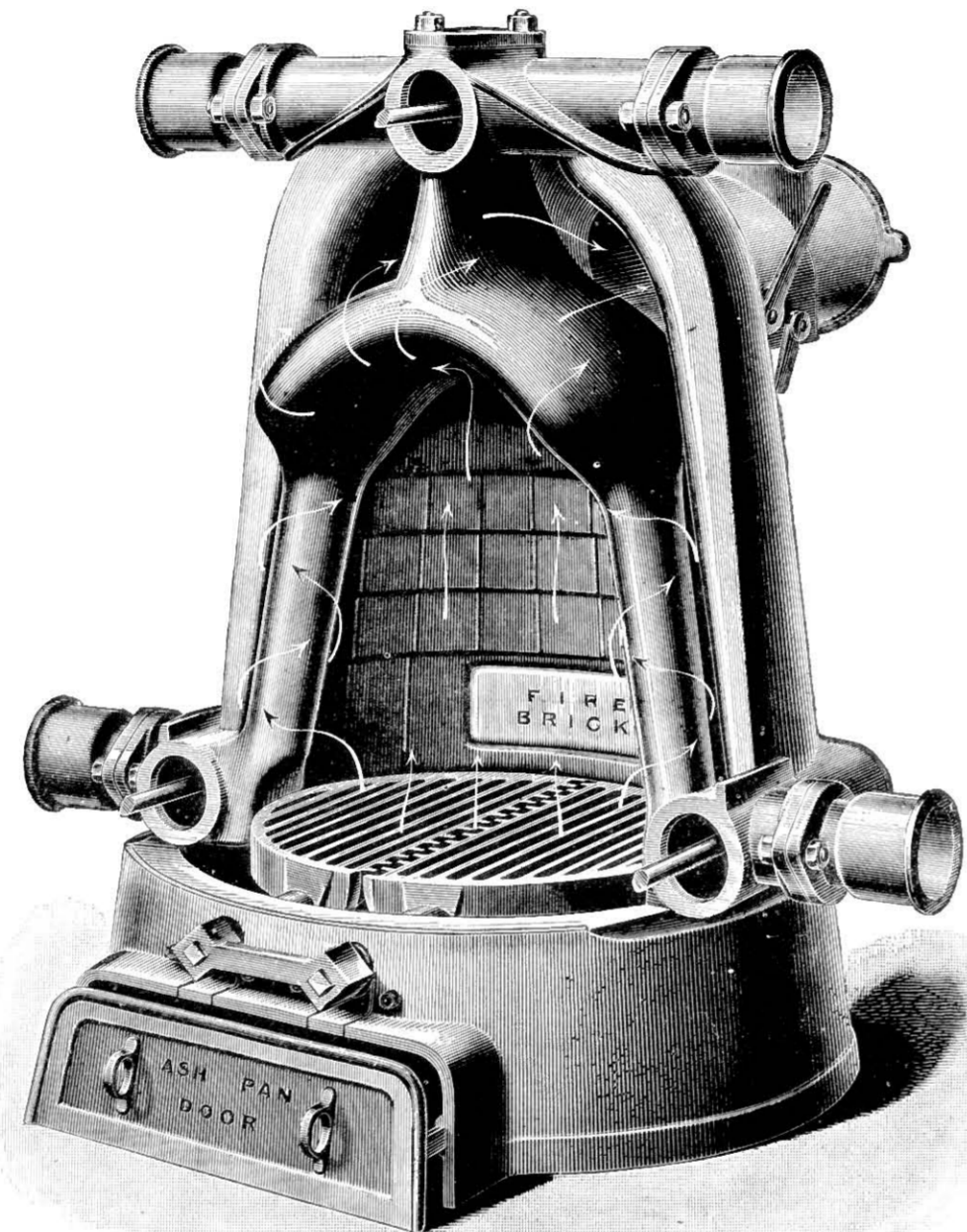

Fig. 514.—View of "Viaduct" Cast-iron Boiler, with the Front Half of the Outer Case Removed.

illustrated in fig. 516. It will be observed that the boiler really consists of a series of coils of pipe, placed in a fire-brick chamber; part of the tubes form the grate-bars, and the flame plays directly on to the upper tubes. The flow of water produced in the tubes is, of course, extremely rapid.

**Körting's Boiler** is shown in figs. 517 and 518. It is designed for low-pressure steam heating, but we describe it here, as a very similar type is also used for hot-water heating. The following description is taken from the maker's list.

"As the boiler is provided with an open stand-pipe ST, there is absolutely no risk of explosion,<sup>1</sup> and the position occupied by the boiler may be decided without reference to the question of safety. As furnace, which serves at the same time as hopper and as fire-grate, we have adopted our patent cast-iron ring tubes (see D, fig. 518), which are filled with water, and are connected at the bottom and top to the water space of the boiler. By removing the cover F on the top of the boiler, the hopper and furnace may be filled with fuel. It is preferable that, where possible, coke or anthracite coal should be used. The air for combustion passes through the draught-regulator, and a flue in the setting of the boiler, to the front of the furnace. As the furnace-door is kept closed, except when the ash is removed, and with closed door the connection between the front of the furnace and the ash-pit is hermetically sealed, the air on its way to the boiler must pass between the water-tubes of the grate, and through the fuel inside the grate. When the furnace-door is opened for the removal of ash, cold air passes direct through the ash-pit to the boiler, checking the draught, and diminishing rather than increasing the combustion in the furnace during the time the door is open.

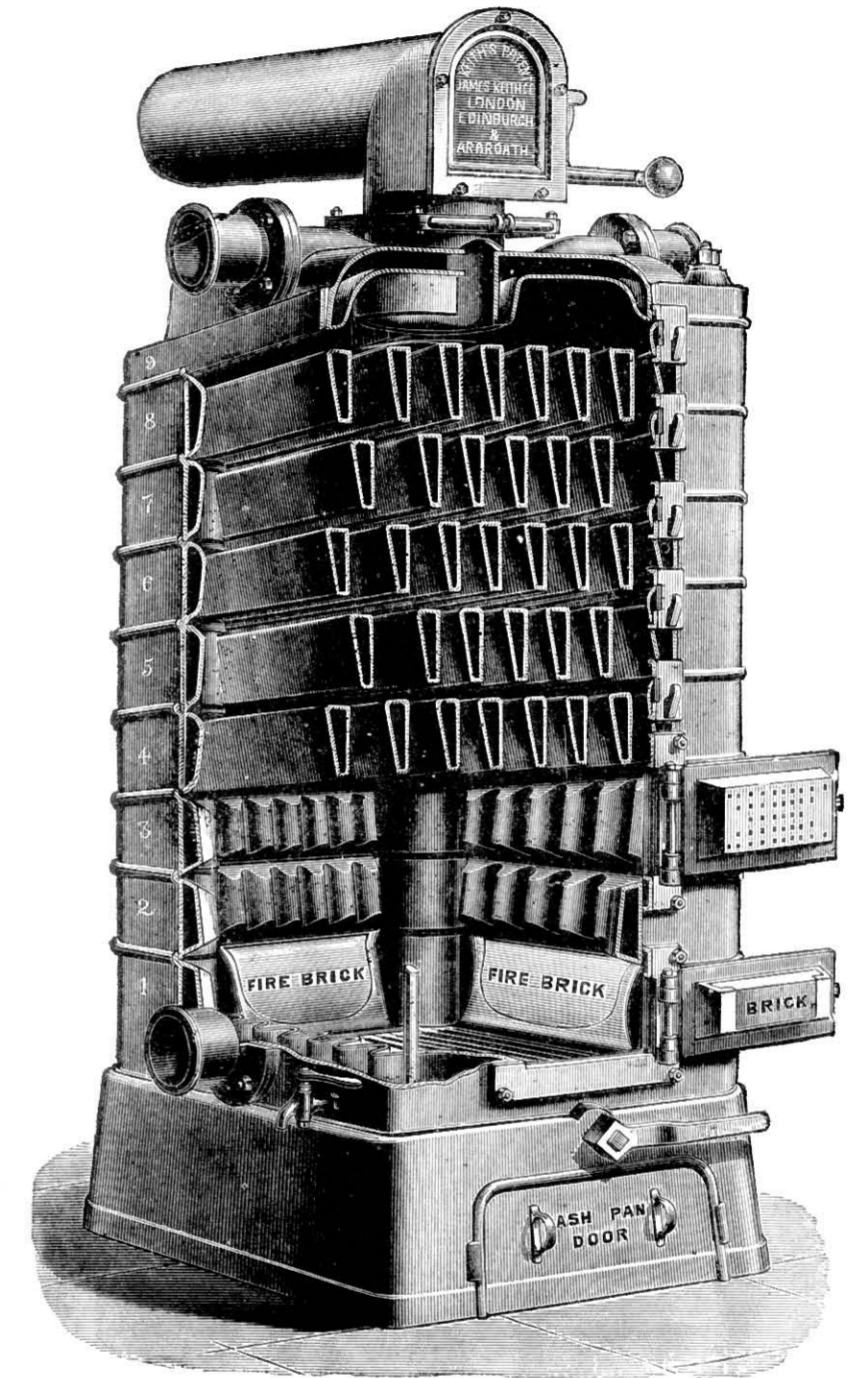

Fig. 515.—Sectional View of the "Challenge" Cast-iron Boiler.

<sup>1</sup> But suppose that the water in this is frozen (as may readily happen if the apparatus is only used on certain days of the week), and the water in the circulation-pipes is also frozen, so that relief cannot be obtained through the air-pipes, then an explosion will be almost a matter of certainty if the fire is lit.—ED.



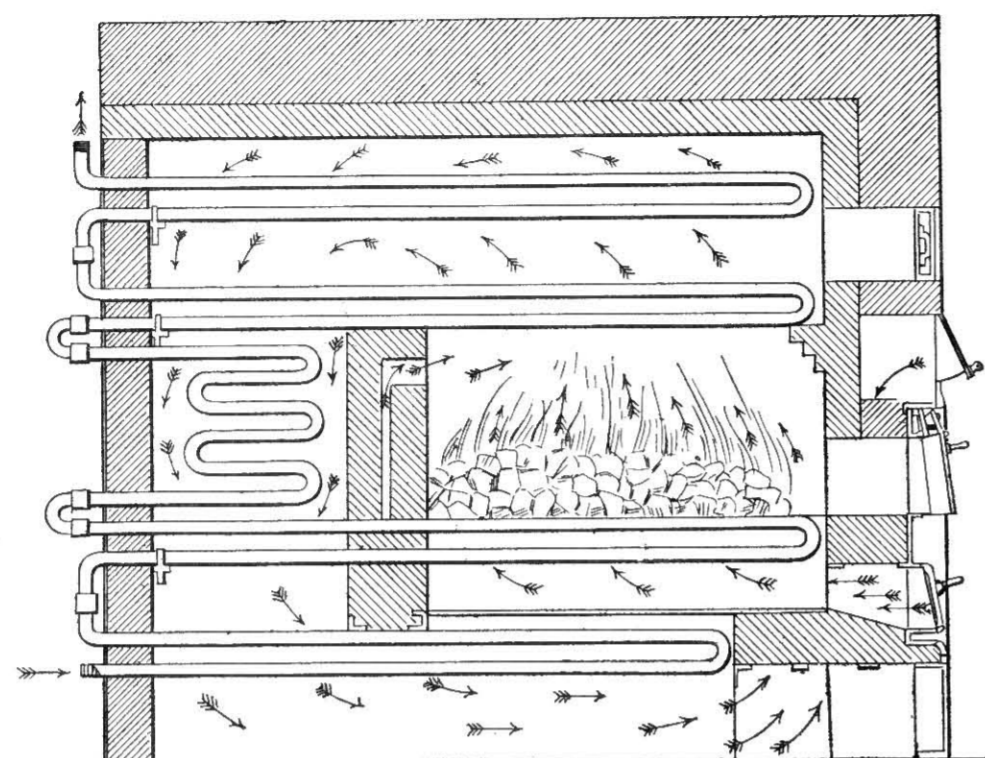

Fig. 516.—Section of the "Renton Gibbs" Tubular Boiler.

The danger is thus obviated that the combustion should be too intense if the furnace-door is inadvertently left open.

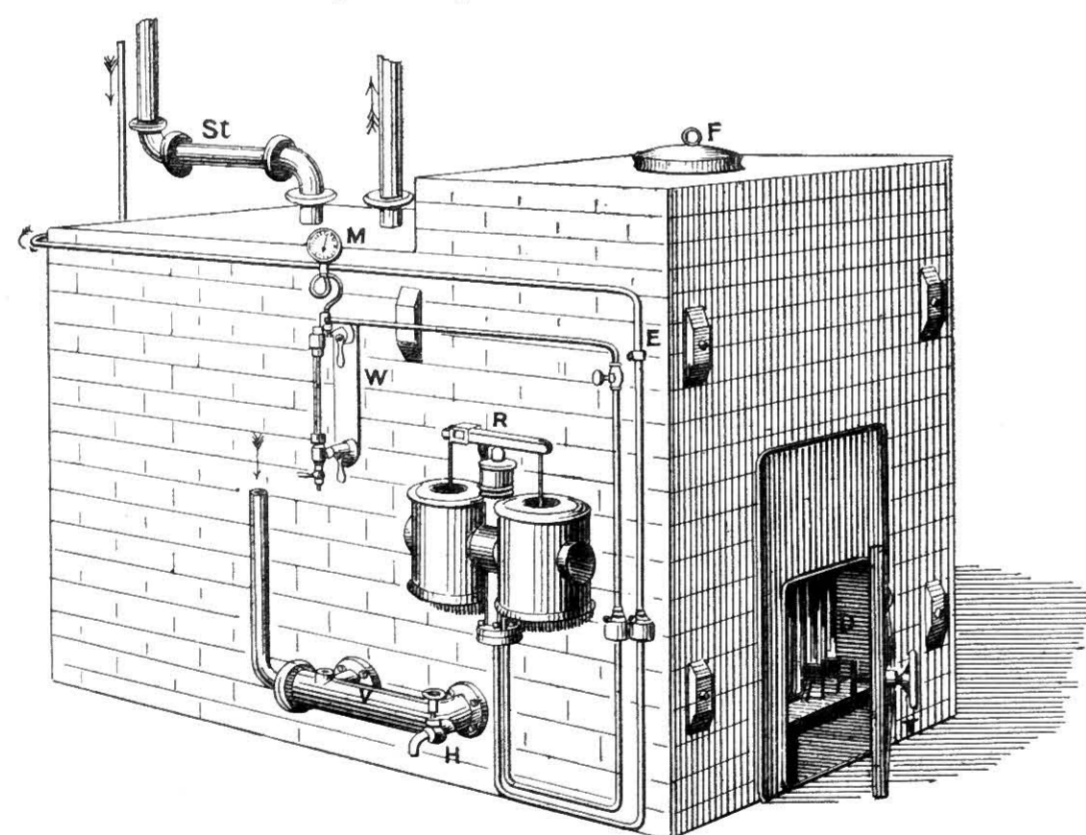

Fig. 517.—View of Exterior of Körting's Boiler.

T, furnace-door; D, patent grate; F, fuel-hopper; R, draught-regulator; M, pressure-gauge; W, water-gauge; H, draw-off cock; V, connection of boiler with water-tube grate, and condensed-water return-pipe; ST, stand-pipe, 16 feet high; E, valve for clearing safety-pipe of water.

"The advantages of the arrangements for firing, as roughly sketched, are

that the combustion of the fuel is exceedingly perfect, and the generation of smoke so small that the problem of smoke-prevention is fully solved; the fuel, which is contained inside the water-tubes, has no direct contact with the brick-work, and repairing or renewal of the boiler-setting is rendered almost unnecessary; and lastly, accumulation of clinker does not form, as the hot clinker suddenly contracts on coming in contact with the comparatively cool surface of

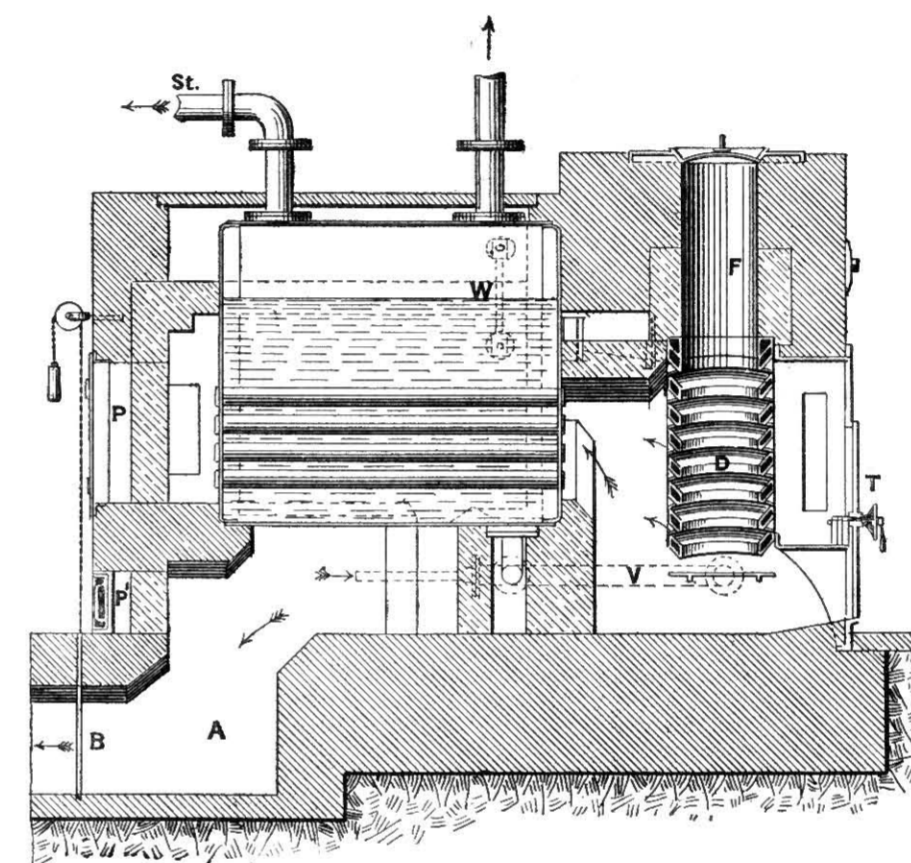

Fig. 518.—Section of Körting's Boiler.

the water-tubes, breaking into small pieces, which readily find their way into the ash-pit.

"The filling-hopper F can be made of any size to suit the kind of fuel in use, and may be sufficiently large to contain two days' supply of fuel. We are making these boilers in ten sizes of from 40 to 400 square feet of heating-surface, and are prepared to make larger ones if required. The attendance required for one of these large boilers is naturally much less than is needed in other systems of heating, where several smaller boilers are used. The work of the attendant is confined to re-filling the hopper F with fuel, which is only necessary at long intervals, and to removing clinker and ash two or three times a day, so that we may claim to have reduced the attendance to a minimum.

"The maintenance of a constant pressure is of special importance with low-pressure steam heating, and we have designed an **Automatic Draught-regulator**



(shown in section in fig. 519) by which this is perfectly secured." This apparatus will be more particularly described in the chapter on heating by steam.

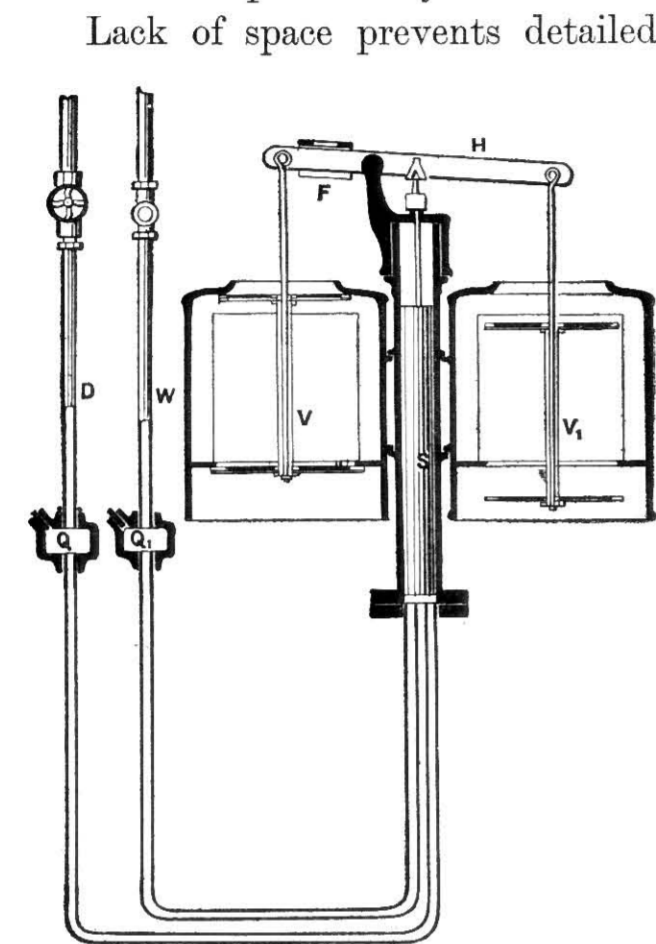

Fig. 519.—Section of Körting's Automatic Draught-regulator.

Q Q<sub>1</sub>, vessels containing mercury; D, steam-connection to boiler; W, water-connection to stand-pipe; S, float; H, lever-arm; F, movable weight; v v<sub>1</sub>, valves for regulating the admission of air.

and made with plain socketed joints, or with special joints as shown in fig. 521. The latter is known as Richardson's expansion-joint, and possesses several distinct advantages. The joint is held together by bolts, and an india-rubber

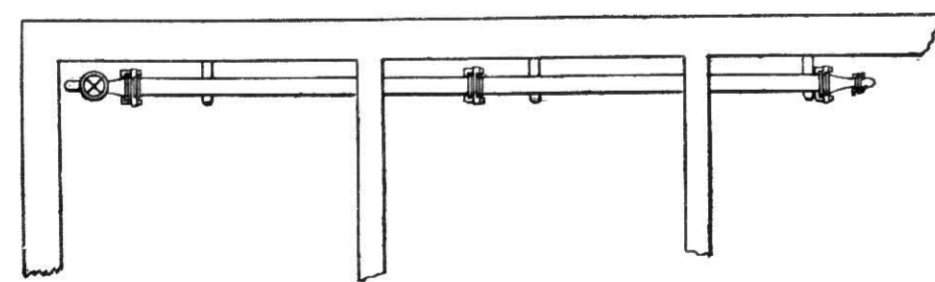

Fig. 520.—Plan of Hot-water Pipe

gland, which grips the pipe and prevents slipping. This type of pipe is somewhat more expensive in first cost than the ordinary socketed variety, but the great facility with which joints can be made renders it little more expensive

Lack of space prevents detailed description of every kind of boiler, but probably sufficient has been said to give the reader some idea of the principal types now in use. We must now pass to the consideration of another and most important part of a hot-water apparatus, namely, the radiator.

Radiators can generally be used either with low-pressure hot water or low-pressure steam; the subject will be best treated here, and need not be referred to in subsequent chapters.

The simplest form of radiating-surface consists of a straight length of pipe, which may be, of course, either wrought-iron or cast-iron. Where appearance is no object—as possibly in the basements of buildings and servants' bedrooms—cast-iron pipes are perfectly suitable, and the method of arranging them is shown in plan in fig. 520. The pipes may be two, three, or four inches in diameter,

is put between the two ends of the pipe. If a length of pipe requires to be shortened, the socket end is cut off, and its place taken by a loose flange, held securely in position by a toothed

when fixed. Straight pipes require to be held either above the floor on small stools, which should be provided with rollers (to allow of expansion) of the form

shown in fig. 522, or they should be supported on wall-brackets as shown in fig. 523, or hung by slings from wall-

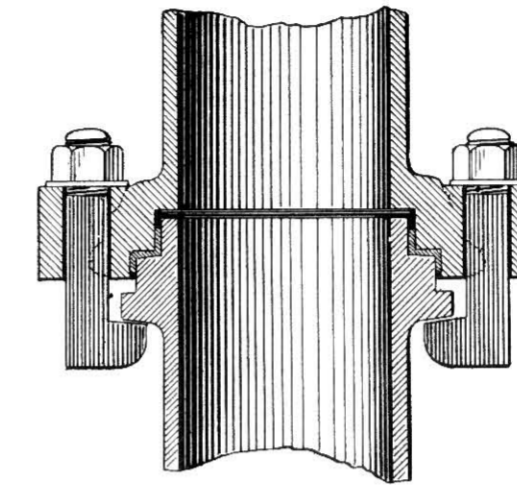

Fig. 521.—Section of Richardson's India-rubber Expansion-joint.

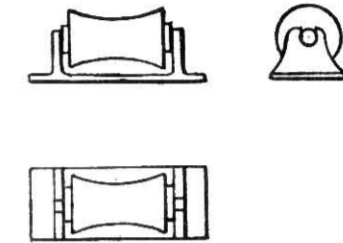

Fig. 522.—Front and End Elevations and Plan of Roller Stool for Pipes.

brackets as shown in fig. 524. They may, however, be supported on simple brackets of T-iron, bent into the form of a hook, and let into the wall, as

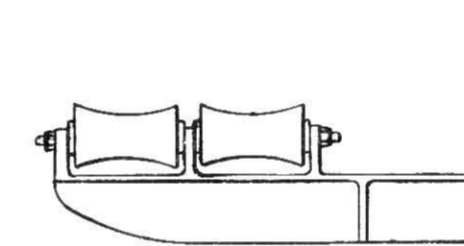

Fig. 523.—Elevation and Plan of Roller Bracket for Pipes.

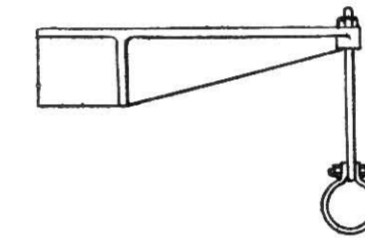

Fig. 524.—Elevation and Plan of Bracket and Sling for Pipes.

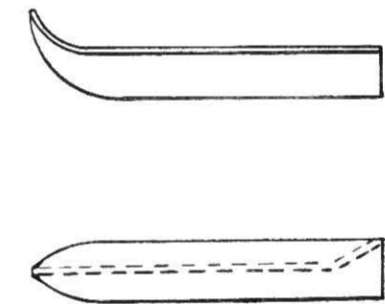

Fig. 525.—Elevation and Plan of T-iron Bracket for Pipes.

shown in fig. 525, and this arrangement is quite sufficient where the lengths of pipe are not very considerable.

There are many cases where pipes of this character would be an eyesore if carried above the floor, but there is a system of placing the pipes in a specially-formed trench covered with a metal grating. There are great objections to this system, as the trench forms a most convenient receptacle for dirt and dust and the sweepings of the floors, and, while harbouring vermin, may be the source of infection. This system is shown in the right-hand part of the ground-floor in fig. 526.

If the pipes are carried round the rooms in a channel formed behind the skirting-board, and protected by a metal grating, there is not so great an objection; this method is shown in the left-hand part of the ground-floor in



fig. 526 and also in 527. The channel above the floor, however, entails certain difficulties, as the pipes cannot well be carried below the doors, as in that case a dip would be formed, which might interfere with the circulation. In order to avoid the difficulties specified, it is found usually more convenient to place the main pipes between the floor of the room to be heated and the ceiling of the room below.

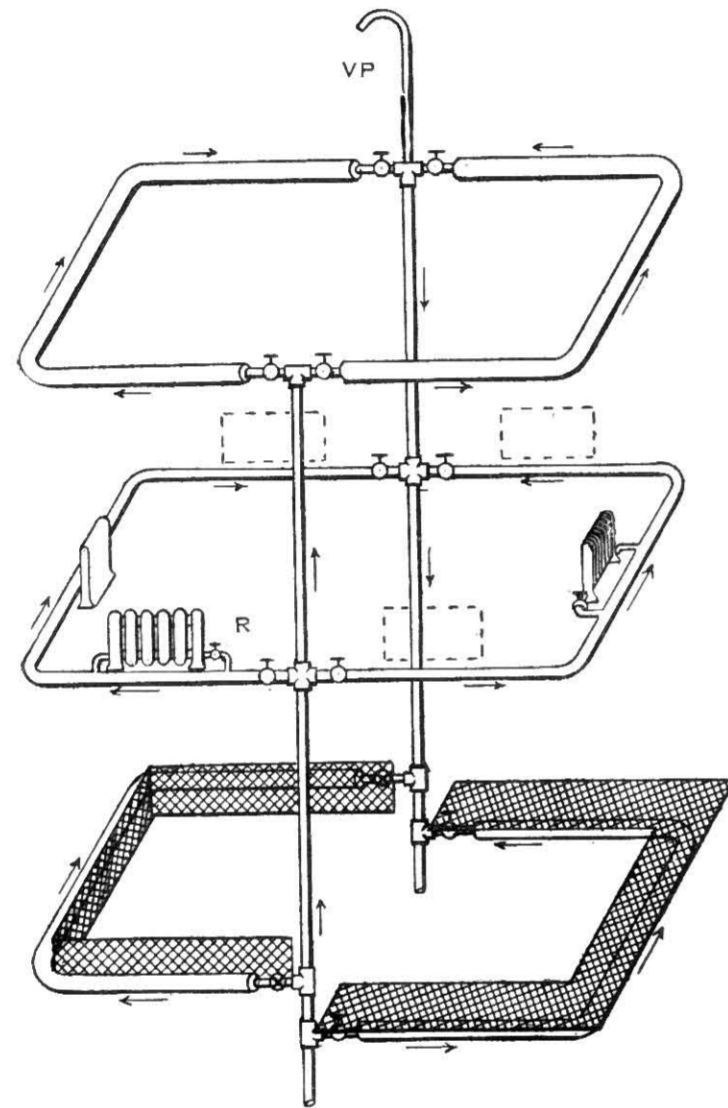

Fig. 526.—Diagrammatic View of Low-pressure Hot-water Pipes  
R, radiator; VP, vent-pipe.

These pipes are preferably carried in a special trench covered with a screwed board, so that access may be obtained to them. If the pipes are thus carried below the floor, it is merely necessary to bring from the main loop short branches to form the inlet and outlet of any particular radiator.

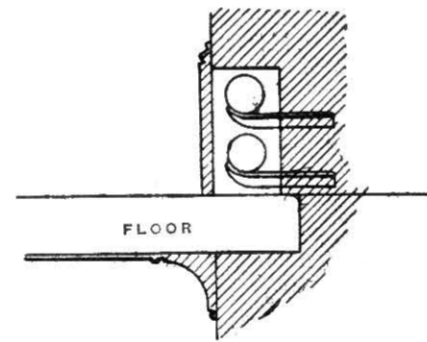

Fig. 527.—Pipes in Channel formed in Wall.

It is preferable to clothe the whole of the pipes where they are not needed for radiating heat, with some **non-conducting material**, such as slag wool, asbestos, magnesia, &c.

Formerly a **very common type of radiator** consisted of two vertical "ends", connected together by a number of horizontal tubes. These coils were usually set close against the wall, but in certain cases were fixed in the middle of entrance-halls, landings, and places of that nature.

These coils have now been practically superseded by a **type having vertical loops**, fastened together in groups of convenient size. The loops are made of different sizes, double, treble, quadruple, &c., and of different lengths. The end

loops are usually provided with feet, and the several parts are shown in fig. 528, which represents a type of radiator known as the Safford; it is manufactured in Canada. A similar radiator is made by Mr. Keith, who has previously been alluded to. In this, each intermediate loop is an exact duplicate of the other, one side of each boss being tapped with a right-hand thread, and the other with a left-hand thread. The loops are then connected together by means of left and right nipples. In some cases the faces of the bosses are carefully machined, so that no packing other than red-lead cement is needed in order to make a tight joint, and in others a washer of paper soaked in boiled oil is employed.

There are some radiators which are **held together by long bolts**. In my opinion these are distinctly inferior to the kind just described, as the bolts expand and contract, and allow of leakage.

The **Coil Radiator**, represented in fig. 529, is made by Messrs. W. G. Cannon & Sons, and has been specially designed to afford a large heating-surface in small compass. There is a main bottom pipe, and connected to this are spiral coils of copper. Each coil is free to expand vertically without reference to any other coil, and although such a radiator is more expensive than the ordinary cast-iron type, it is very efficient in working.

The coil is shown with a connecting tube at the top, as well as at the bottom,

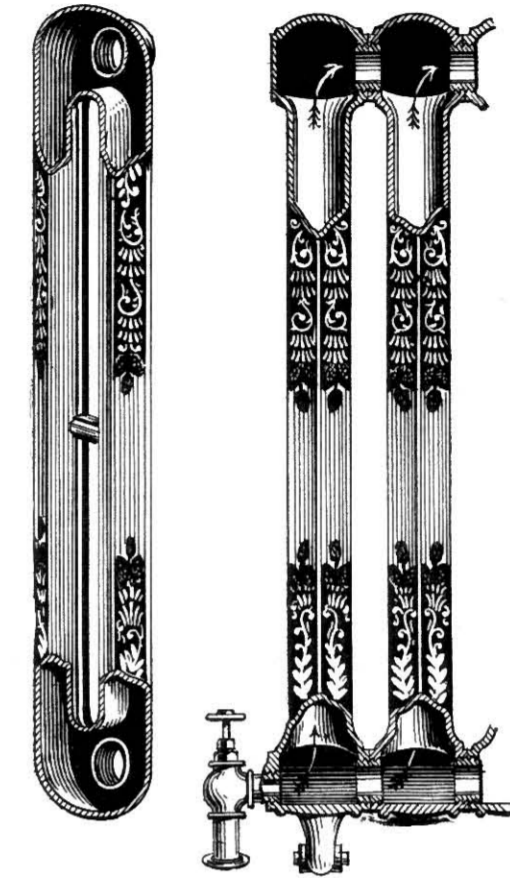

Fig. 528.—Section and View of parts of the "Safford" Radiator for Hot Water.

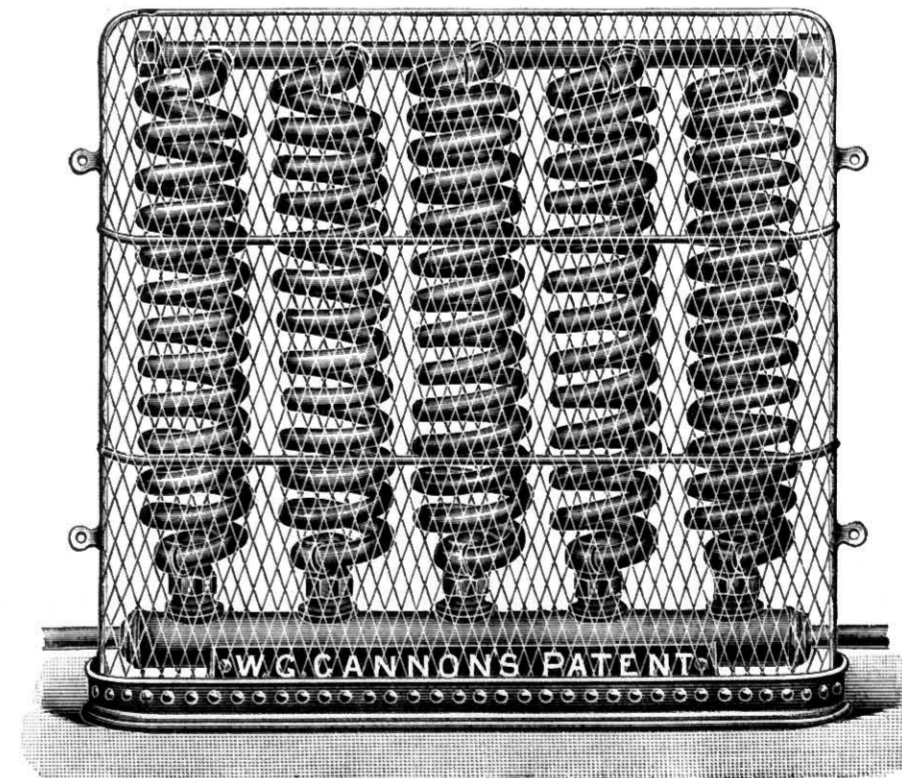

Fig. 529.—Coil Radiator, with Wire Guard.



and the whole is protected by a wire guard, to prevent children from burning their fingers. The same type is also made inclosed in a cast-iron case with a door for access, and hit-and-miss gratings on the top and in front, as shown in fig. 530. There is also a hit-and-miss grating behind, affording access for the external air, which passes out through the upper grating into the room.

I have already drawn attention to the desirability of **warming the incoming air** which is used for heating and ventilation, and the present is a fitting

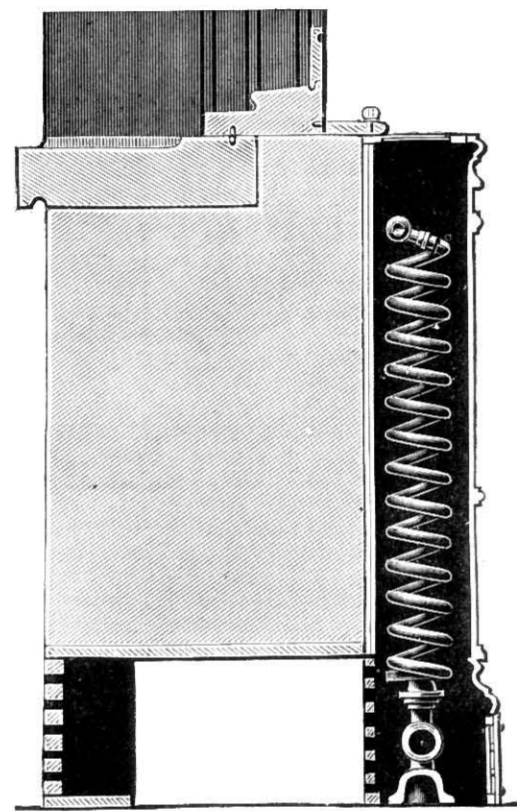

Fig. 530.—Section showing Coil Radiator in Cast-iron Case, with Air-inlet, &c.

opportunity for pointing out several methods by which this result may be obtained. As shown in fig. 530, a special air-inlet must first be provided in the external wall, and the inside of this opening should be carefully rendered with Keene's or other hard cement. The exterior face of the opening should be protected with a cast-iron grid, which is so fixed in its frame as to be capable of easy removal, when the inside of the opening is to be cleaned. The inner face of the inlet should be provided with a suitable hit-and-miss grating, and the inlet itself should be as near the floor-level as possible; this hit-and-miss grating must be capable of adjustment by means of a handle, which comes to the outside of the case either at the side or at the top. The case itself, which is usually of cast-iron, may be made as ornamental as may be desired, but it should have a hit-and-miss grating of ample size on the top, and also at the front close to the floor. The action of the radiator and case is as follows. In mild weather the inlet-grating is opened to its full extent, the front grating in the case closed, and that in the top of the case opened wide. The heat of the radiator causes an upward current of air through the upper grating, and the external air passes in to take its place. The warmed air passing into the room will have a temperature dependent upon the temperature of the radiator, and upon the velocity of the air passing through the external wall. If now it be found that the volume of air entering the apartment is too large, the grating at the inlet may be entirely closed, and the grating in the front of the case opened. Air from the floor-level of the room will then be drawn into the case, and will pass upwards among the coils of the radiator, and out into the room through the top grating.

There will, in that case, be a circulation of the air in the room only, and the outlet-ventilator, at the ceiling or the floor-level as the case may be, must be kept closed. As no fresh air is allowed to enter from outside, the atmosphere of the room will rapidly become "stuffy", and therefore judgment is needed in opening and closing the external grating.

Such radiator-cases are not considered suitable in all circumstances, but there are other means of arriving at the same end: for instance, fig. 531 represents a **ventilating radiator** quite different from those just described; each separate loop is screwed into the base, and no india-rubber is used in making the joints. In the non-ventilating type the fitting ends with the hollow base into which the pipes are screwed, but in the ventilating type this is fixed upon a special box provided with a large number of small holes in the front of the case near the floor. The usual inlet is provided in the external wall, and protected by a grid. In the base casting a special valve is fixed, consisting of two hinged plates, coupled together by bolts. When this compound valve is pulled forward the holes in the case are closed, and the

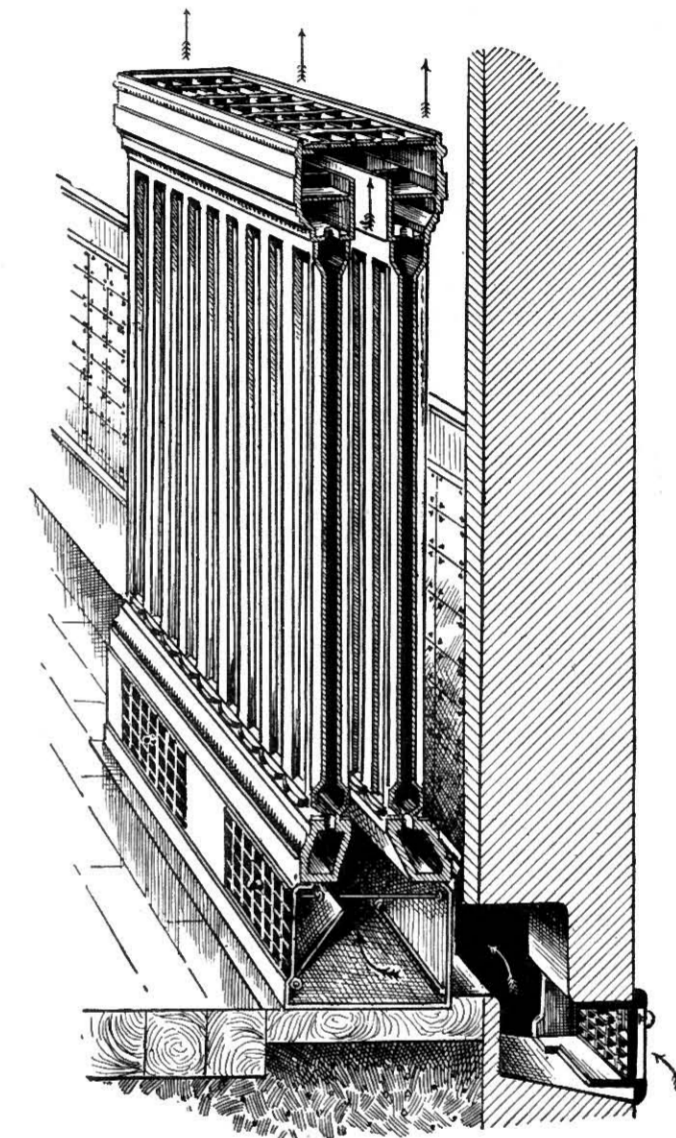

Fig. 531.—Sectional View of Rosser & Russell's Ventilating Radiator.

external air has a free course up between the two rows of tubes, and out through the holes in the top grating; when the valve is pushed in, the external air cannot enter, but the air in the room is free to circulate through the inside of the radiator, as in the case of the radiator previously described. In rare cases cotton cloth or muslin is fitted in the inlet passage, in order to partially clean the air entering the room, but in the great majority of instances this is not done. All arrangements of this kind require attention at regular intervals for cleaning, otherwise they become mere receptacles for dirt, and the air passing into the room may be rendered more impure than the external air.

It is always desirable to have the connections of the pipes to the radiators



made in such a manner as to permit of the **removal of the radiator for cleaning**, as in the last instance it is by no means easy to render the lower box perfectly clean. The dark stain, which will appear above the radiators if they are placed against a wall will clearly prove what a quantity of dust is carried up with the current of heated air.

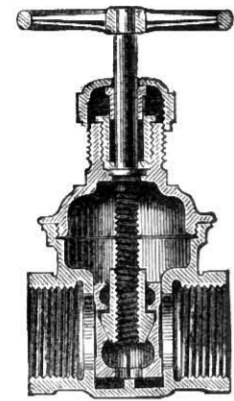

Fig. 532.—Section of Full-way "Peet" Valve.

**Stop-valves** are very important items in a heating-installation, and it is very poor policy to buy cheap valves, as these are a never-ending source of annoyance. For hot-water work there can be nothing better than a full-way cock, either of the "Peet" type, shown in section in fig. 532, or one of the other types described later. The "Peet" valve consists of two separate disc faces, separated by a wedge-shaped part controlled by a screw. When closed, the two discs shut tightly upon their seatings, and are held there by the pressure of the hand-screw. Such valves are not so suitable for steam, but are well adapted for hot water; the great point which requires attention in a hot-water heating-installation, is that no resistance which can possibly be avoided be offered to the passage of the current.

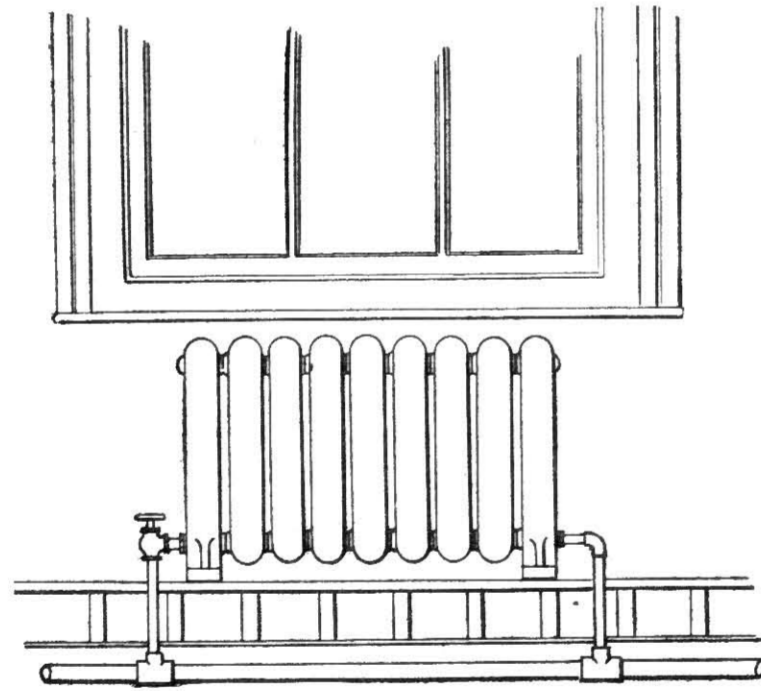

Fig. 533.—Radiator with Elbow Stop-valve.

I shall now consider the various ways in which the apparatus may be arranged. The heat, whether obtained from the combustion of coal or coke, gas or oil,

<sup>1</sup> **Safety-valves** are important adjuncts of hot-water apparatus. Numerous explosions, many of which have been attended with loss of life, have occurred in consequence of the omission of these safeguards. The principal cause of explosions is the blocking of the pipes with ice in frosty weather, but stoppage by incrustation may also occur. The simple dead-weight safety-valve is among the best, but as the subject of safety-valves has already been treated in Section IV., pages 253 to 257, nothing further need be said here.—Ed.

Another type of stop-valve is shown in fig. 533, and is specially adapted to form an elbow for a radiator connection. These valves should be of gun-metal of good quality, and the plug may consist merely of a conical plug, fitting into a hole turned accurately to receive it; the plug is entirely withdrawn when the valve is fully open, and therefore leaves a full water-way.<sup>1</sup>

Having described in some detail the various pieces of apparatus used in hot-water heating,

must be applied to the lowest part of the system, for the simple reason that heated water will naturally be forced upward by colder water. From the usual tables we learn that, when water is heated from 32° to 212° Fahr., it will expand about one-twentieth of its original volume; such an amount of expansion must obviously be allowed for in any form of apparatus, and if this is not done, the containing parts will be liable to burst. In a low-pressure system the pipes must be open to the air at one or more points. Fig. 534 shows the simplest possible system for heating pipes by low-pressure hot water. T represents an open metal tank filled with water, with a pipe connected to it as shown. So long as the tank and pipe are full of water at the same temperature, there is no tendency to circulate, but let a lighted lamp

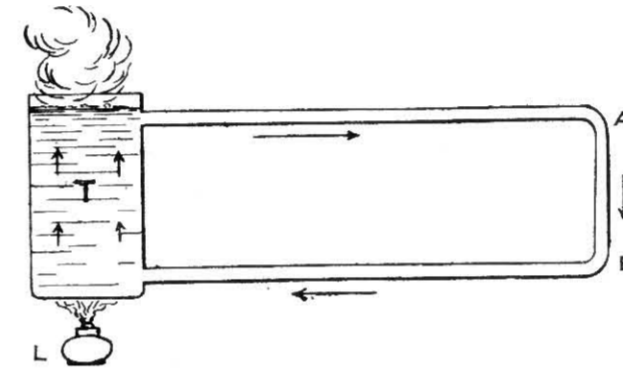

Fig. 534.—Simplest System of Low-pressure Heating.

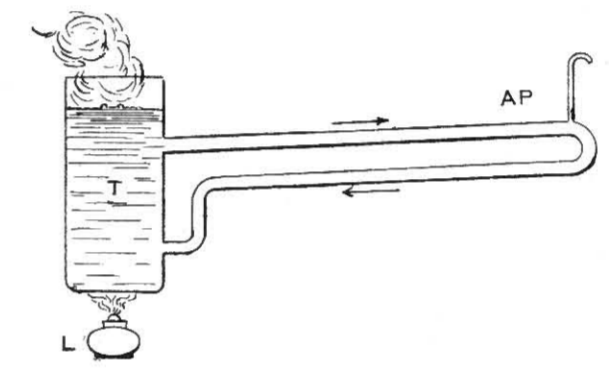

Fig. 535.—Simple Low-pressure Hot-water Apparatus with Air-pipe.

L be applied to the bottom of the tank and heat the water contained therein, then the water in the portion A B will be colder, and therefore heavier, than the corresponding column in the tank, and the action of gravity starts a circulation in the direction shown by the arrows. Now, such an apparatus is obviously too crude to be of practical use. A large amount of heat is lost from the exposed surface of the water, and if the water is lowered by only a slight amount, the upper connection of the pipe will be uncovered and the circulation stopped; but by far the most serious objection is, that it is impossible to carry any part of the pipe above the surface of the water. Air is always present in water, and in such an apparatus bubbles of air might easily collect at A, and impede the circulation. The latter difficulty could be overcome by arranging the pipe as in fig. 535, with a rise to the point A, and there providing an outlet by means of the air-pipe A P.

In the application of the system to practical cases **several points must be carefully observed:**—

- (a) The heater must be below the lowest part of the circulation-pipes.
- (b) Means must be provided for the expansion of the water produced by the application of heat.



- (c) Means must be provided for keeping the apparatus full of water.  
 (d) The circulation-pipes must rise continuously to the highest point and then return gradually to the heater.  
 (e) Means must be provided for ridding the apparatus of air.

Fig. 536 represents diagrammatically **an apparatus for heating two floors**

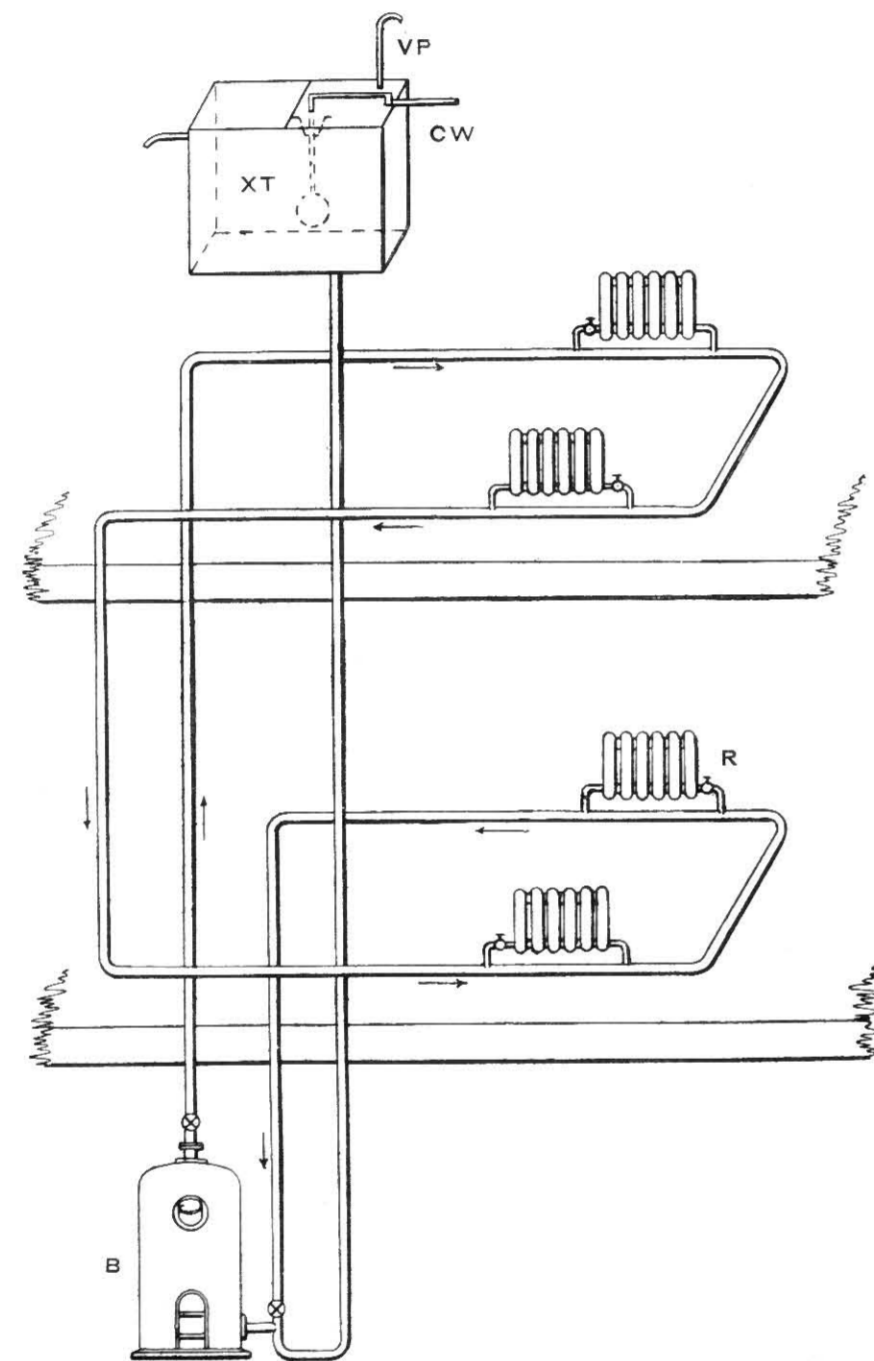

Fig. 536.—Diagrammatic View of Low-pressure Hot-water Apparatus for Heating two Floors with one Circuit.

one above the other. The heater is placed in the basement, and of course cannot be left open as those shown in figs. 534 and 535. At a point somewhere above the highest part of the heating-apparatus, will be placed the expansion-tank, which also acts as a feed-cistern for the apparatus; this is marked XT, and is fed with cold water from any convenient source by the pipe CW. The water in this tank never rises more than (say) 4 inches above the bottom of the tank, and actuates a float, which controls the inlet-valve just as an ordinary ball-cock does, but in this case the valve itself is preferably put outside the tank, and the tank covered over and provided with a vapour-pipe VP, which is carried into the open air over the roof. From the top of the heater is carried the rising

main, which goes direct to the highest part of the building, and thence round the two floors in the manner indicated. This pipe itself, if of adequate size, would effect the heating of the rooms, but there are several reasons why it is generally inadvisable to use such pipes in houses. In order to obtain the

requisite surface in the length disposable, it would be necessary to use pipe from 3 inches to 4 inches in diameter, and this would seldom be convenient in a private house, as there are doorways to be passed, and a large pipe is very unsightly. A small pipe can be run behind a skirting-board, or under the floor-boards; branches are then taken off to each radiator as shown, and the only parts of the apparatus above the floor are the radiators and their connections. These connections are all taken off the return-pipe, which descends to the heater and is connected to it at or near the bottom; a pipe is carried down from the expansion-tank, and has a U-shaped bend at the bottom, connected to the return-pipe close to the heater. The action of the apparatus will be as follows. With the system full of cold water, the height of the water in the expansion-tank will be (say) 4 inches; as soon as heat is applied, the water will expand up the vertical pipe into the tank XT, and will close the ball-cock, and if it should expand sufficiently, it will pass away by the overflow; hot water will then pass round the system in the direction of the arrows. The valves are marked by an X within a circle. It will be seen that, while the whole of the system can be shut off from the boiler, it is impossible for high pressure to be got up in the boiler, as it is always in open connection with the expansion-tank; the worst that can happen is for boiling water to pass up into the expansion-tank.

This is probably the cheapest scheme which could be devised. The main pipes might be  $1\frac{1}{2}$  inches in diameter, and the branches to the separate radiators  $\frac{3}{4}$  inch. The heat in each of the radiators can be readily controlled by the valve next to it, but there is no means of emptying a portion of the apparatus so as to allow of the repair of a joint or other similar work. If a second stop-valve were put on the other side of each radiator, this would allow the radiator itself to be removed, but as it would add about 7s. 6d. to the cost for each extra valve, it is not usually done. Although only two radiators are shown, it is by no means intended that the number should be so limited.

The methods of connecting radiators with the system of pipes deserve mention. It will be observed that, in the last figure, each radiator has a branch off the main, and another back into it, as shown more clearly in fig. 537. In fig. 538, an alternative arrangement is shown with the inlet branch off the flow-pipe and the outlet into the return. If the radiators were arranged so closely together as shown, they might work quite well under the alternative arrangement, but there is always the danger of a short circuit being set up from flow to return, so that while the first radiator would get thoroughly hot, the second might be only warm, and the third almost cold. Such a



thing could not occur with the upper arrangement, and it should always be used except where the branch off the main is so long, and feeds so much radiating surface, that the water is at a very low temperature when it gets back.

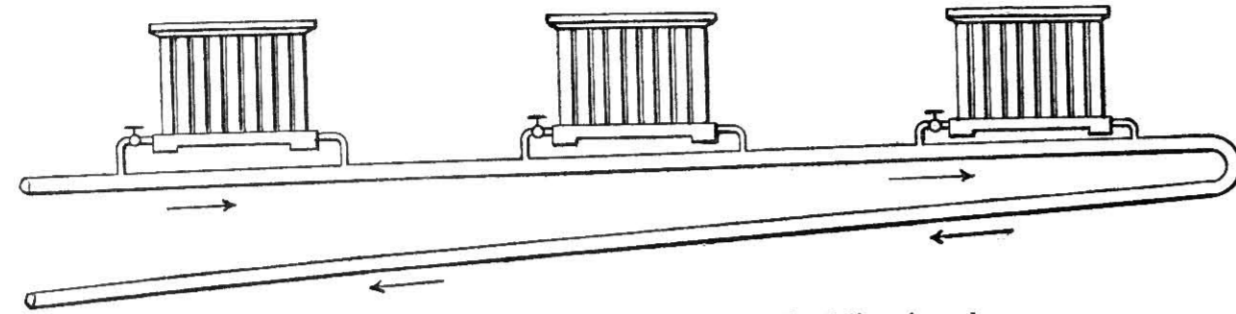

Fig. 537.—Method of connecting Radiators to one Circulation-pipe only.

It is advisable then, and then only, to use the lower arrangement. Radiators connected to a branch circulation-pipe are often on the one-pipe system, as shown in fig. 539. A great saving of pipe can thus be effected, upon what

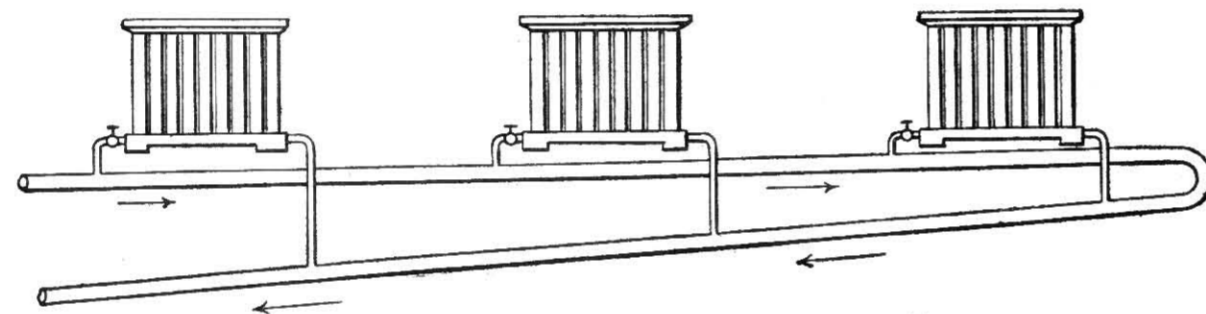

Fig. 538.—Method of connecting Radiators to Flow and Return Pipes.

would be required if both the flow and return pipes were carried along side by side, and the connections made as in fig. 538.

Another arrangement of pipes is illustrated in fig. 540, where each floor is shown to be warmed by a separate circuit. This arrangement is usually adopted in large buildings. Each floor can then readily be shut off, and means can be provided for emptying each of the mains separately at the points c c. It will be necessary to provide air-cocks at the highest point of each of the horizontal runs. It is often somewhat difficult to arrange a method of carrying horizontal pipes on upper floors; doors may be so placed that it is impossible to carry the pipes above the floor, and it may be very difficult to form a suitable channel in the floor itself.

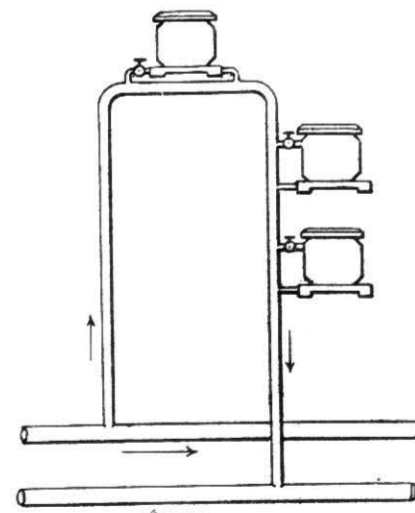

Fig. 539.—Radiators on Branch Circulation-pipe.

For the heating of a ground-floor, the position of the pipes may be just below the basement ceiling, as shown in fig. 533. This illustration shows the

main pipe of wrought-iron  $1\frac{1}{2}$  inches in diameter, carried in the basement just below the ceiling, and from it are taken off the branch flow and return pipes to the radiator. The radiator should preferably be placed in a window recess, or, if the reveals of the window are not carried down to the floor, it should be

placed as close to the wall as possible. An upward current of heated air is then created, which prevents cold draughts from passing direct from the window into the room. Such radiators may be arranged to ventilate the room as well as warm it by direct radiation, if a suitable grating be arranged in the outer wall, and

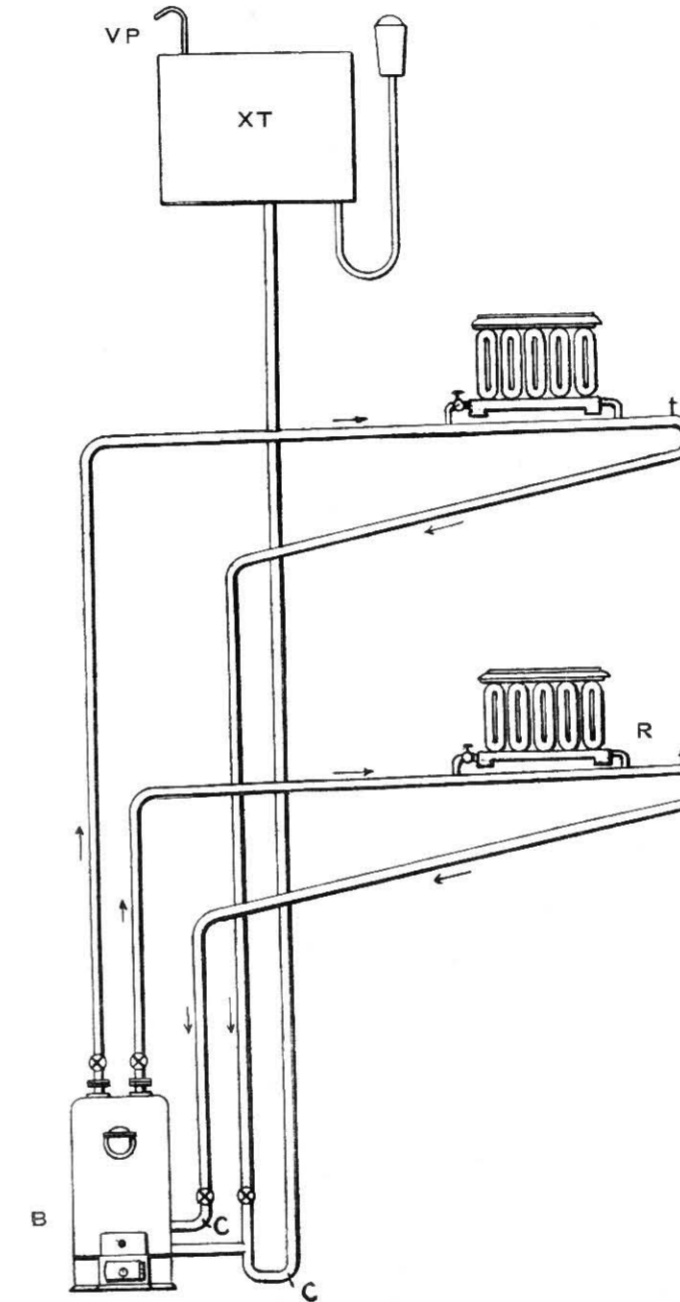

Fig. 540.—Elevation of Low-pressure Hot-water Apparatus, with Separate Circuit for Each Floor.

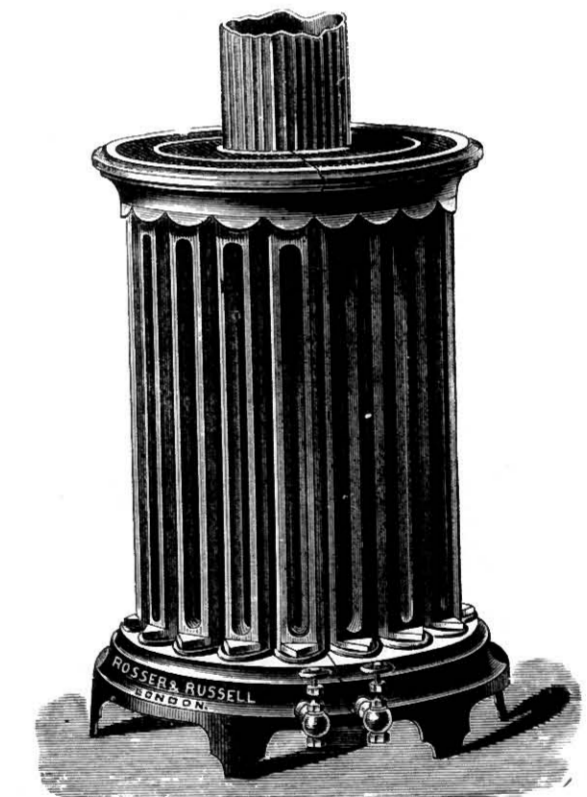

Fig. 541.—View of Circular Radiator for Hall.

suitable baffle-plates inside; details of these have already been given in figs. 530 and 531. For the hall, a radiator of the type illustrated in fig. 541 may be used.

In heating the rooms on the first-floor the same plan cannot be adopted, as of course the main pipe could not be carried through the best rooms on the ground-floor. One plan, therefore, is to prepare a special pipe-channel behind



the skirting-board, as shown in fig. 527, page 124, but even this is not always possible on account of doorways. The pipes, may, however, sometimes be carried between the joists, but should in all such cases be covered to prevent radiation of heat.

Another arrangement of pipes may be adopted, which consists in carrying a main of suitable size entirely around the basement, just below the ceiling, and

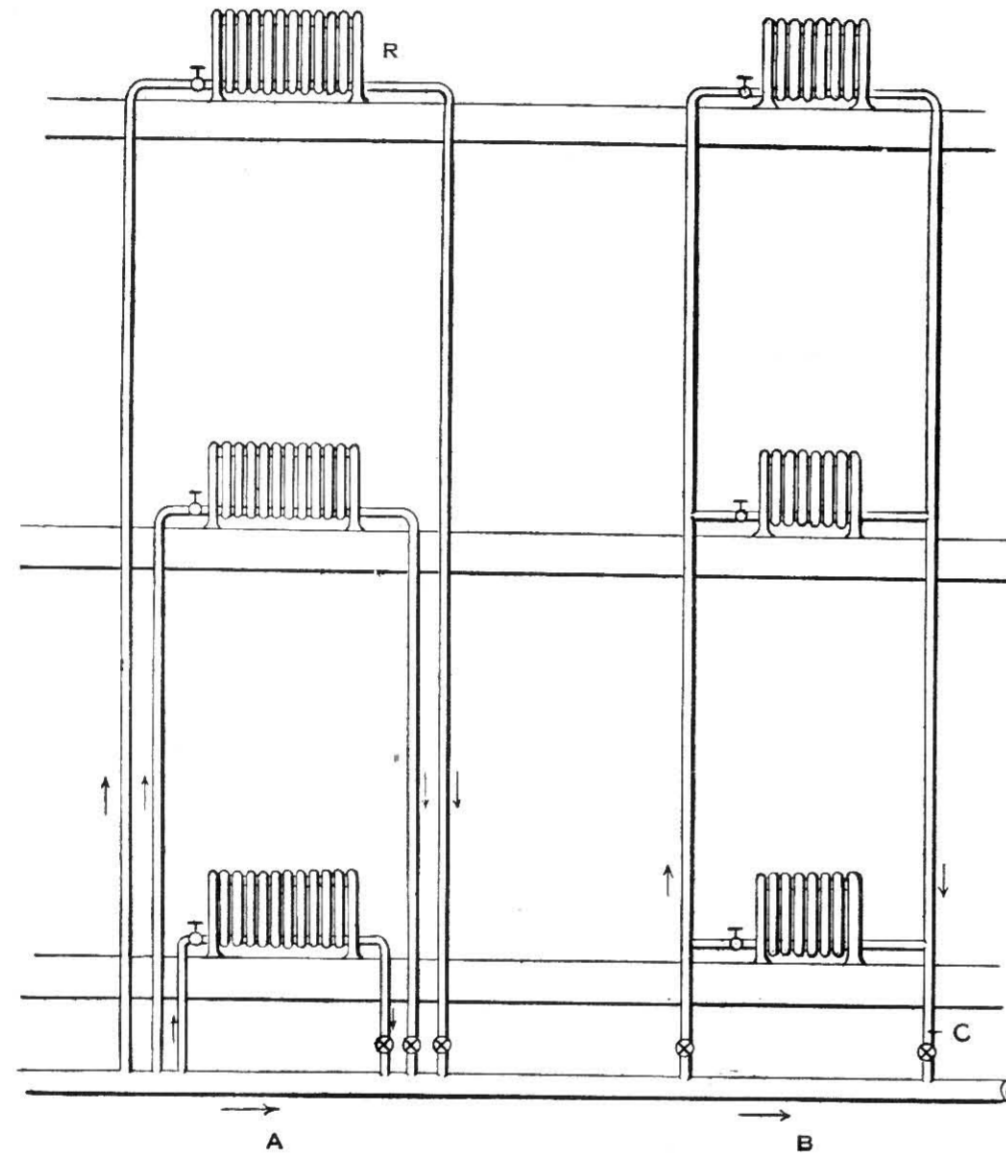

Fig. 542.—Elevation of Pipes for Low-pressure Heating, showing two Arrangements of Vertical Flow and Return Pipes for Radiators.

taking vertical flow and return pipes from this, as shown in fig. 542. In the part lettered A, each radiator has a special flow and return; there is, therefore, nothing whatever to interfere with a good and efficient circulation. The only objection to the system is the number of pipes required. In part B another system is shown, in which there is only one vertical flow and one vertical return; the sizes might be  $1\frac{1}{4}$  inches to the first branch, 1 inch thence to the second branch, and  $\frac{3}{4}$  inch to the top radiator. It would be well to have a stop-cock close to the main, in both flow and return pipes, and if an outlet be arranged at

c the whole of the loop can be emptied, except the short flow-pipe as far as the first branch. The disadvantage of such an arrangement as that shown, is that the water may flow past the ends of the branches without entering them. There is not the slightest risk about the top radiator, as that is sure to heat well, but there is always a danger that the ground-floor radiator may not get satisfactorily hot. In most of the illustrations, the flow and return pipes are shown to be connected with the same main-pipe, but in some cases, where there is a very long run of branch-pipe before it returns to the main, it is desirable to take the return-pipe back into the return-main, as shown in fig. 539, page 132, as the two last radiators would receive water at too low a temperature to work efficiently, if the long loop were connected up to the flow-pipe only.

Another plan, which has been widely adopted in the United States, and generally referred to as the "Mills" system of piping, is to take the flow-pipe direct to the top of the building, and thence to take a number of pipes down as returns to the boiler, as shown in fig. 543. Here the flow-pipe is carried up to the top floor, and feeds a ring-main carried round the building; from this ring descend vertical pipes to a similar ring in the basement, and from the latter ring is taken the return-pipe (or pipes) to the boiler. This gives a very satisfac-

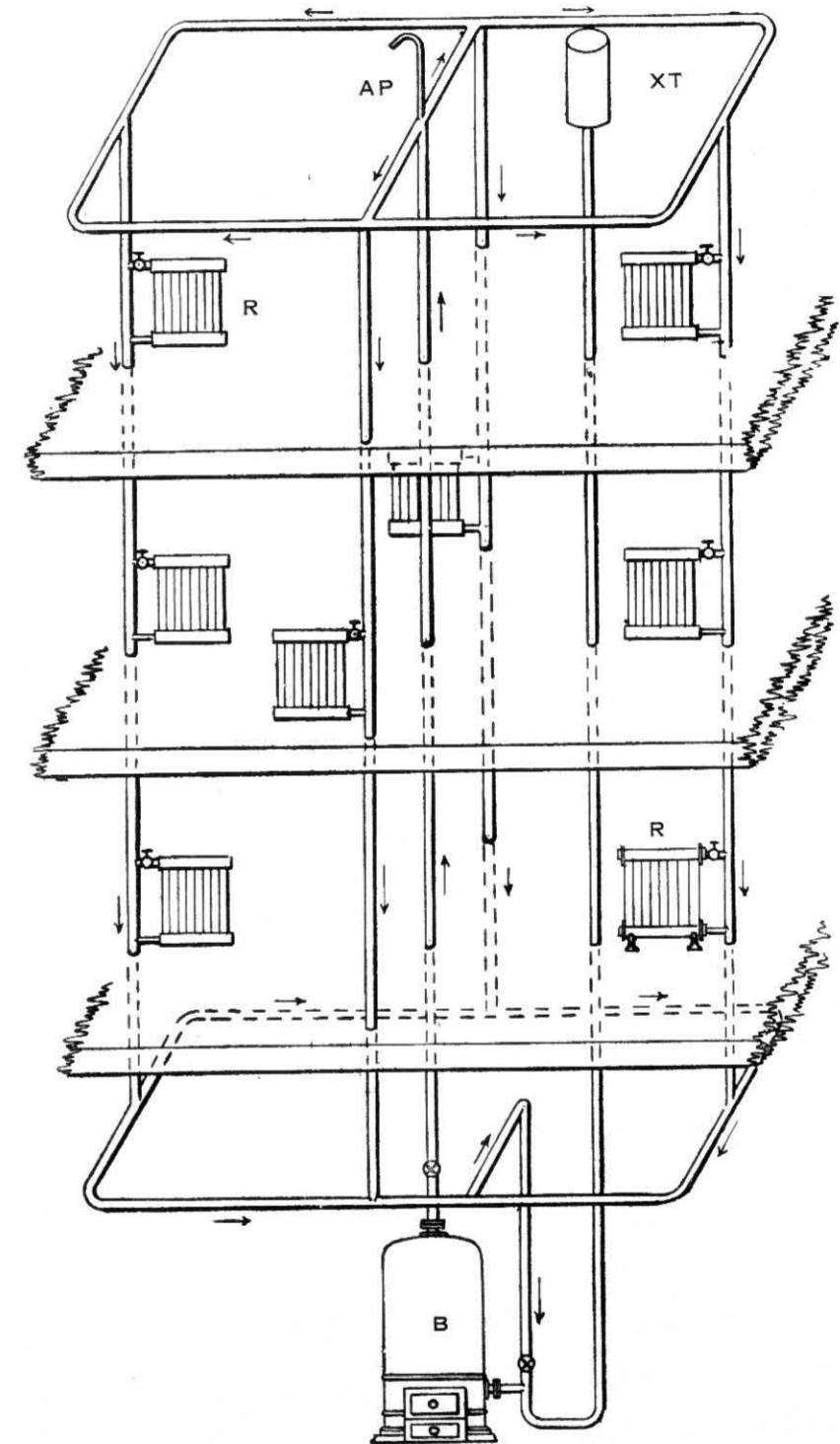

Fig. 543.—Diagrammatic View of the "Mills" System of Piping for Low-pressure Hot-water Apparatus.  
B, boiler; R R, radiators; AP, air-pipe; XT, expansion-tank.



tory result, but if it be considered unwise to depend upon a single flow-pipe, it is easy to take a flow up to the top for each loop. This arrangement is well adapted for use in tall houses of four or five floors; it is, however, open to the objection that the hot water may pass the branches to the radiators without entering them, although it must be said that there is less chance of this in the present case than in that illustrated in fig. 542. When only one flow-pipe is employed, it should have an area approximately equivalent to that of all the return-pipes taken together.

In cases where there are no intervening doorways or fireplaces, a **3-inch or 4-inch cast-iron pipe** may be arranged, as shown in fig. 520, page 122. This is fed by a small wrought-iron pipe, and for small bedrooms or basement rooms quite sufficient heat will be obtained at much less expense than if radiators are used. In private houses, it is not likely that such an arrangement will be considered suitable, except for servants' rooms.

**The low-pressure heating-apparatus for a suburban house** is shown in Plates XVIII. and XIX. The vertical type of boiler has been chosen, as it takes up the least room; it is fixed at a level of about 18 inches below the basement floor, in order to allow for the return of certain pipes which are carried below the basement passage. The smoke-flue from the boiler consists of an iron tube carried into any convenient flue which can be used. The boiler itself is provided with a multiple pipe for the flow, and a similar pipe for the return, a "multiple pipe" being merely a pipe provided with several branch-outlets. The expansion-tank marked x r in Plate XIX. is placed in the cistern-room, and fed from the cold-water cistern. A pipe descends direct from this cistern to the boiler to provide a constant feed. There is absolutely no danger of explosion,<sup>1</sup> as the expansion-cistern is open to the atmosphere through a vapour-pipe carried through the roof, as shown in the plate.

**Three distinct loops of heating pipes** are provided for this house. The flow-pipe of *the first loop* begins at the multiple pipe on the top of the boiler, rises to the ceiling of the boiler-house, passes along close under the ceiling of the scullery and kitchen, and rises in the corner of the kitchen through the ground-floor into the drawing-room; there it rises vertically inside a case, passes through the first floor, and rises vertically through bedroom 1 into bedroom 5; in bedroom 5 it is carried along the floor inside a skirting-case, feeding a radiator at the window, then passes alongside the wall in the cistern-room without any

<sup>1</sup>During the winter of 1896-7, not less than *three* explosions of low-pressure heating boilers occurred, killing one man, injuring another, and doing considerable damage to property, and in every case there was an expansion-cistern open to the atmosphere. The pipes were, however, blocked with ice. The statement in the text is true, so long as the water-way in all the pipes remains open.—Ed.



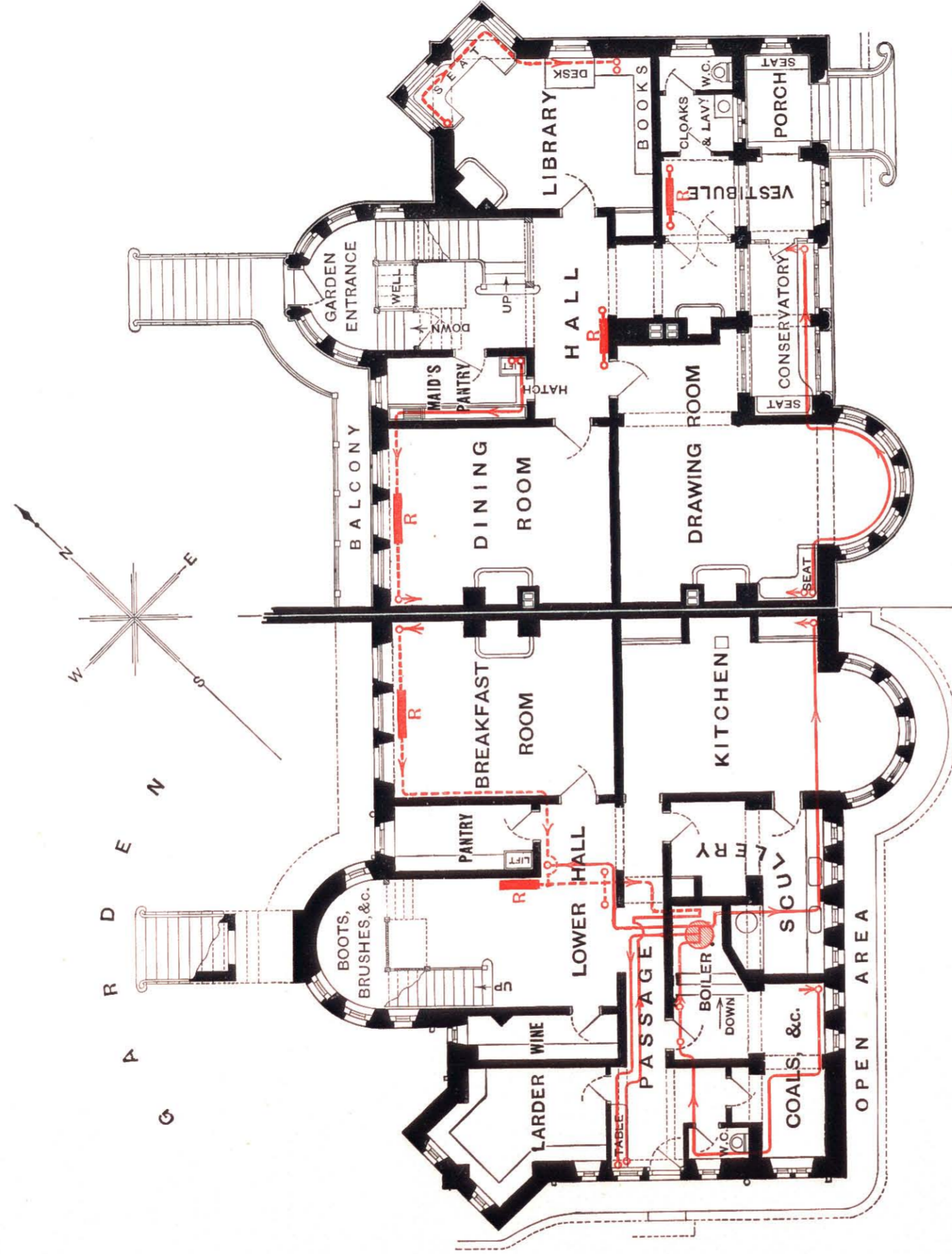

PLAN OF GROUND FLOOR.

PLAN OF BASEMENT.

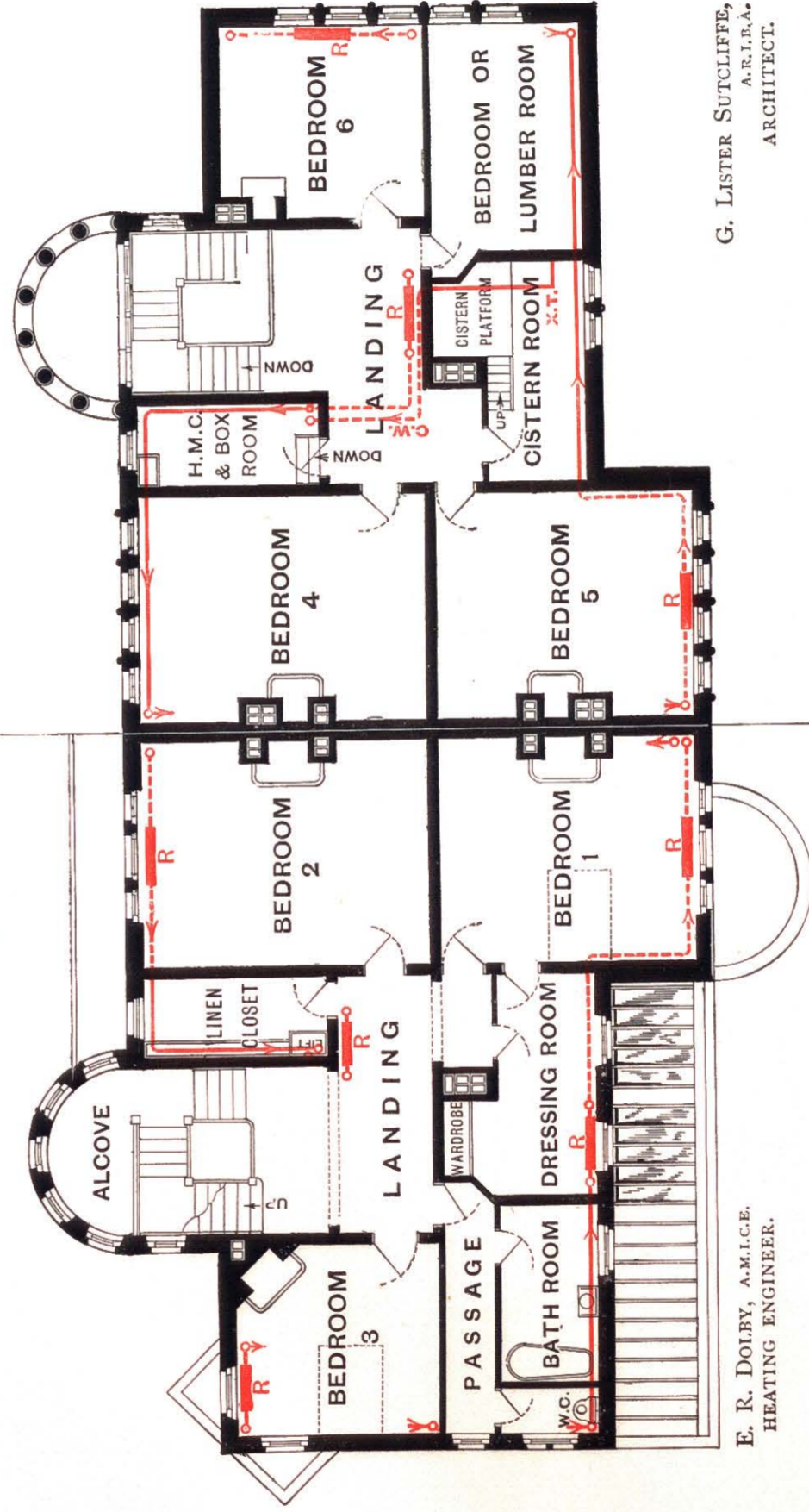

PLAN OF FIRST FLOOR

PLAN OF SECOND FLOOR



G. LISTER SUTCLIFFE,  
A.R.I.B.A.  
ARCHITECT.

E. R. DOLBY, A.M.I.C.E.,  
HEATING ENGINEER.

PLANS OF A PAIR OF SUBURBAN HOUSES, SHOWING SYSTEM OF HOT-WATER PIPES FOR HEATING PURPOSES.

The pipes in the basement are nearly all carried along the ceilings. The arrows on the pipes indicate the direction of the flow. R.R.=Radiators.



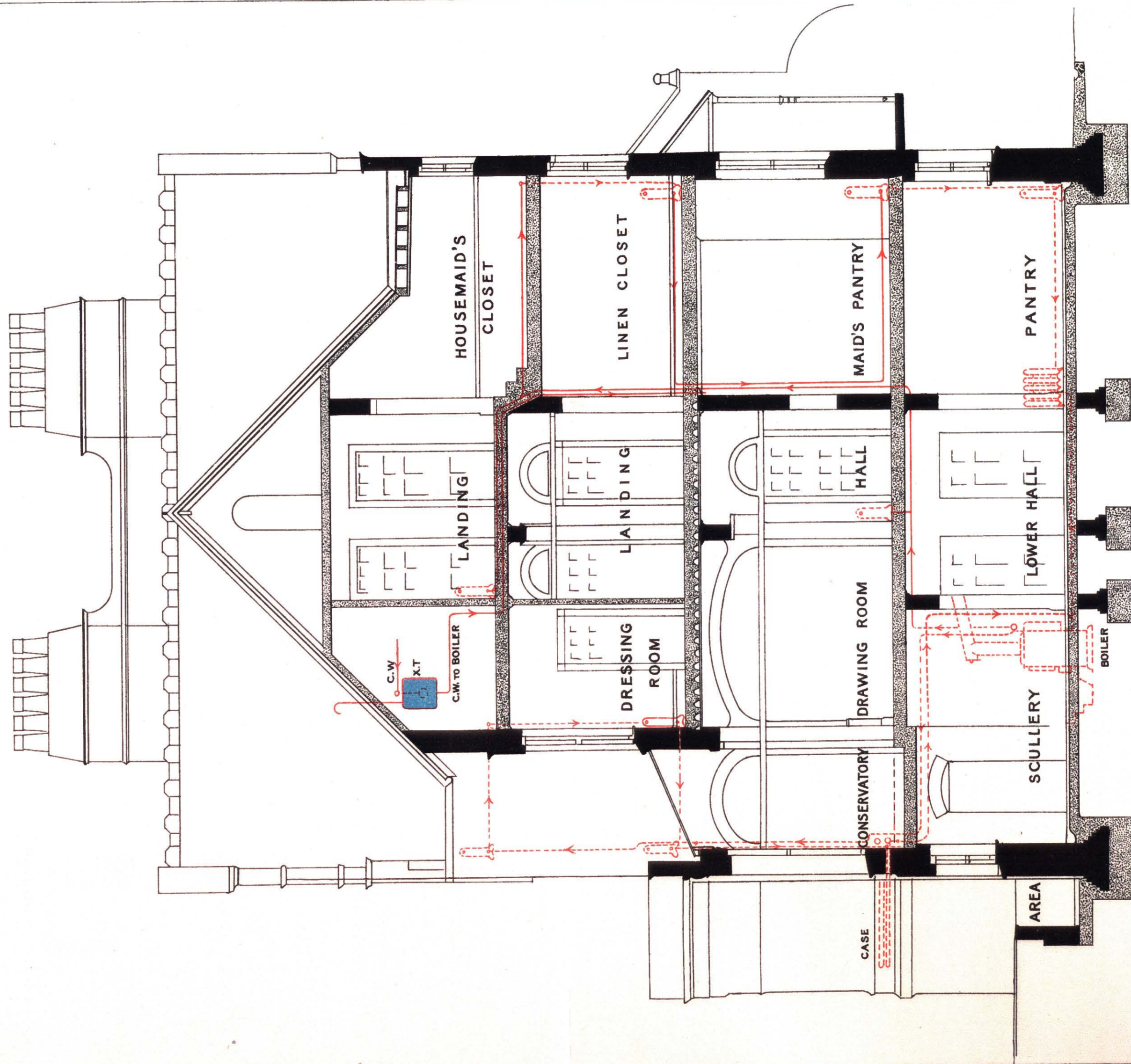

G. LISTER SUTCLIFFE, A.R.I.B.A.,  
ARCHITECT.

E. R. DOLBY, A.M.I.C.E.,  
HEATING ENGINEER.

0 1 2 3 4 5 10 15 20  
F E E T

NOTE.—THE ARROWS ON THE PIPES INDICATE THE DIRECTION OF THE FLOW.

SECTION THROUGH SUBURBAN HOUSE, SHOWING HEATING PIPES.



casing, and is carried similarly through the lumber-room; thence it descends into the W.C. on the first floor, passes along just above the floor of the bath-room, feeds a radiator in the dressing-room, and is then carried in a skirting-case through bedroom 1, feeding a radiator at the window, descends in a case in the corner of the drawing-room alongside the flow-pipe, and feeds a coil inside a casing carried round the bay-window of the drawing-room, this case being fitted with an open-work front; the pipe then passes along the conservatory, feeding a coil placed below the flower-stands, descends through the ground-floor into the coal-cellar, feeding a radiator in the porch, and passes close to the ceiling through the W.C. into the boiler-house, feeding a radiator in the vestibule, and then passing down is connected to the main return.

*The second loop* runs as follows:—The flow-pipe begins at the multiple pipe on the top of the boiler, rises to the ceiling, passes across the passage close under the ceiling, across the lower hall, rises through the ground-floor, passes vertically upwards inside the lift in the maid's pantry, and thence into the box-room on the second floor. The radiator on the landing of the second floor is fed from it, and it is then carried along the floor through the box-room, through bedroom 4, descends to bedroom 2, passes along bedroom 2 in a skirting-casing, feeding a radiator at the window, and thence along the floor of the linen-closet, feeding a radiator on the landing; it descends inside the lift to the maid's pantry on the ground-floor, and passes into the dining-room, running in a skirting-case and feeding a radiator at the window; it then descends into the breakfast-room, and is carried round two sides in a skirting-case, feeding a radiator at the window; it is afterwards led across the lower hall and passage in a small channel provided with a cover, and feeds a radiator in the lower hall and also one in the hall on the ground-floor.

*The third loop* runs as follows:—It rises to the ceiling of the boiler-house, then running below the ceiling of the passage rises into the library, passing up inside a special casing into bedroom 3, thence into bedroom 6, and passes along the side of this bedroom in a skirting-case, feeding a radiator at the window; it descends in the corner into bedroom 3, feeds a radiator at the window, and descends again into the library, there passes round the window, feeding a coil, and runs in a skirting-case along the wall, and finally descends into the basement and back to the boiler beside the flow-pipe.<sup>1</sup>

<sup>1</sup> Every hot-water warming-apparatus must have a draw-off cock fitted to the boiler, or to the return-pipe near it, in such a manner that *all* the water throughout the system can be drawn off. The emptying of the pipes, &c., is a necessary preliminary before certain repairs and alterations can be executed, and during winter ought to be effected *whenever the fire under the boiler is allowed to go out*. Allowing the fire to go out and the pipes to remain full of water is the most prolific cause of boiler-explosions.—ED.



## 2. THE HIGH-PRESSURE SYSTEM.

In my description of the low-pressure system of heating by hot water, it was pointed out that the apparatus was in communication with the open air, so that no pressure, except that due to the height of the water in the apparatus, was possible. If, however, the apparatus be made of sufficient strength, it may be closed entirely, and in that case temperatures may be attained which cannot be reached with the low-pressure system. It is quite usual for a high-pressure system to show a temperature of 300° to 350° Fahr. on the pipe-coils, whereas with low-pressure coils a temperature of about 150°-180° is usually not exceeded.

Mr. A. M. Perkins was the inventor of the high-pressure system about the year 1837, so that it is by no means a novelty to-day. The system consists in the use of very strong wrought-iron pipes, having an internal diameter of about  $\frac{7}{8}$  inch, and an external diameter of  $1\frac{5}{16}$  inch. These pipes are joined together in the manner shown in fig. 544; the end of one pipe is tapered both inside and outside to a sharp edge, and the end of the other is left square, and one

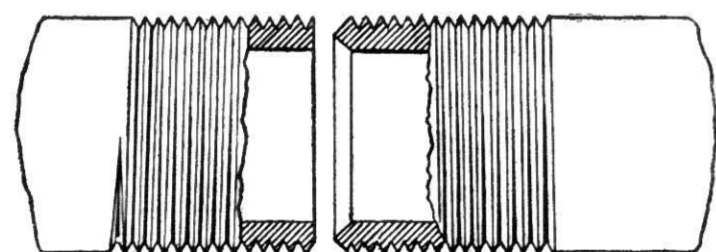

Fig. 544.—Method of Joining Pipes for High-pressure Heating.

end is threaded with a right-hand thread and the other with a left-hand thread. The two pipes are connected with a right-and-left-threaded socket, no jointing material of any kind being used; the sharp edge of the one pipe is merely forced against the flat face of the other. The pipe is continuous throughout, and is coiled upon itself to give the proper heating-surface in the furnace.

The general arrangement of the system is shown in fig. 545. The coil B is placed inside the furnace, and the coils R R are the radiating media; these are

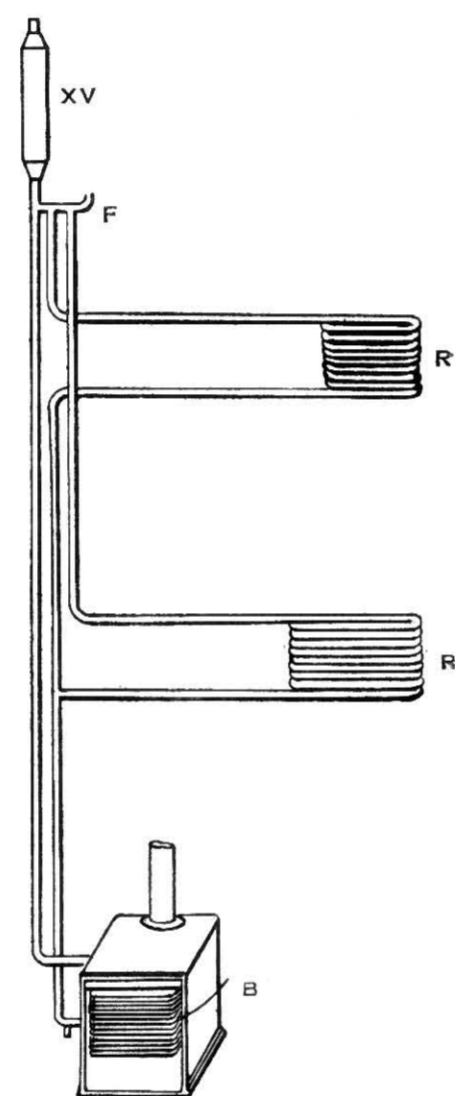

Fig. 545.—View of High-pressure Hot-water Apparatus. B, boiler; F, filling-pipe; XV, expansion-vessel; R R, radiators.

somewhat unsightly, and must be inclosed in ornamental cases if used inside rooms. At the top of the house is fixed a filling-pipe F, which can be sealed off with a proper plug, and above that is an air or expansion-vessel x v, consisting usually of a piece of pipe of rather larger diameter. No air-cocks are required, and no cistern for filling the apparatus. It is merely filled in the first place through the filling-pipe F; the stopper is then fixed, and the apparatus may be started. As soon as the fire in the furnace is lighted, the water begins to expand, and compresses the air contained in the expansion-vessel. A very rapid circulation is set up throughout the apparatus, which will of course continue so long as the fire in the furnace is attended to. The smallness of the pipes renders it possible to put them in places where the large cast-iron pipes of the low-pressure system could not possibly be fixed, and floor-channels of very small size will accommodate quite a large number of pipes. The rapidity of the circulation has also another advantage: it enables the pipes to be carried below the doorways, that is, to dip down in a way quite impossible with the low-pressure system. With the latter, the great objection to a "dip" is that the air will become locked in the higher part of the pipe, but this cannot occur with the high-pressure system, as it is pumped quite full of water and then sealed up; for the same reason no dirt can get in, and no extra water needs to be added to make up for evaporation, as no evaporation can occur. The pipes are often run along the whole length or width of a room at the back of the skirting-board, which is then replaced by a metal grating, allowing the exit of the heated air; or a coil is placed inside a special case with hit-and-miss gratings, and an opening to the external air, as already explained in connection with low-pressure radiators. There is some little difficulty about shutting off a portion of the system, and judgment needs to be exercised.

The pipes, being of such small diameter, are of very small capacity, and the volume of water can, therefore, be readily heated to a high temperature in a very short time; this is in many cases a distinct advantage, but in a house it is not of much consequence, as the fire in a domestic apparatus is rarely allowed to go out during the whole of the cold season.

The small volume of water in the pipes renders the system particularly liable to fluctuations of temperature, due to the varying condition of the fire in the stove, and this needs somewhat more careful attention than that of an ordinary low-pressure apparatus. Again, if stop-valves are used to shut off part of the apparatus the fire must be regulated to suit, otherwise the proportion of pipe in the stove will become excessive for the length used as a radiating medium, and the exposed pipe will therefore become too hot. The usual proportion of



pipe in the stove to the exposed part, is about as 1 to 10 for ordinary heating work. Of course, in the case of a public hall, where all or none of the heating would be required, the problem is simple, but where, as in the case of a house, the requirements fluctuate, the problem becomes somewhat more complicated. Many private houses, however, are satisfactorily heated by this system.

---

## CHAPTER VI.

### LOW-PRESSURE STEAM HEATING.

The system of heating by low-pressure steam is very similar to that of heating by low-pressure hot water, except that, instead of having an apparatus quite full of water and open to the air, so that it is not possible to produce steam above atmospheric pressure, the apparatus is closed and never allowed to get full of water. Steam is generated in a special boiler,—which is placed below the lowest point to be heated,—and then passed into a system of pipes, which are carried into the parts of the building to be warmed, and either themselves give off the heat, or feed apparatus specially designed for that purpose. It is obvious that in the passage of steam through a system of cold pipes a great deal of condensation must take place; the water thus condensed must be carried off as fast as it is formed, and should be used over again in the boiler. For this purpose special pieces of apparatus known as steam-traps are used, which allow free passage to the hot water, but prevent the exit of the steam. All the water passing out has at one time been steam, and is therefore perfectly pure, and if used in the boiler will cause no incrustation; besides this, it holds a large portion of the heat which has originally been in the steam itself.

It may now be advisable to recall to mind a few facts relating to steam, including its formation, and the heat which is contained in a given quantity. The British "thermal unit" is defined to be that quantity of heat which will raise one pound of distilled water 1° Fahrenheit in temperature; thus the work of raising one pound of water at 32° F. to 212° F. would be 180 thermal units. But to change one pound of water at 212° F. to one pound of saturated steam at 212° F. and atmospheric pressure, will require 966 thermal units, and the heat required to raise one pound of this steam to a pressure of one pound above the atmosphere will be 0.3 thermal units. The large quantity of heat which is absorbed in the change from the liquid to the gaseous state, is called "latent

heat"; this heat is given back during the change from vapour to the fluid state. When steam, therefore, is used for heating purposes, the heat due to its temperature is made use of, and when it condenses in the pipes it gives off the latent heat, and is taken back into the boiler as hot water.

There is a very considerable difference between steam and hot-water heating in the following respect: the quantity of heat contained in the pipes of a hot-water apparatus when full of water is vastly greater than that contained in a steam apparatus when full of steam, although the perceptible temperature of the latter, when tested by a thermometer, may be considerably higher than that of the former. It must be remembered that the capacity of the water for heat is much greater than that of the gaseous steam; the result therefore is that, if steam be shut off, it takes but a short time for the pipes to become quite cold, while, in the case of hot water, the heat is retained for a very considerable time. Heating by hot-water pipes is not subject to such rapid fluctuations as may be the case with steam-pipes. In hot-water systems the pipes must have a good fall back to the boiler, otherwise the circulation will be impeded; the air also must be got out of the pipes. In the case of steam systems it is even more important that the condensation or return pipe should fall towards the boiler, otherwise pockets of water will be formed, which will be blown out suddenly by the steam with loud crackling noises. Air must of course also be got out of the pipes, but in the case of steam at low-pressure the air would be heavier than the steam, and would therefore need to be drawn off at the bottom of the apparatus, and not at the top, as would be the case with a hot-water apparatus.

The principal points which require attention in the design of a low-pressure steam heating-apparatus are—firstly, that the whole of the parts are amply strong enough to bear the pressure to which they will be subjected, and secondly, that the pipes are so laid that the water produced by condensation passes away freely under the influence of gravitation.

The boilers used for low-pressure steam-work closely resemble those used for low-pressure hot-water heating, and the latter types of boiler are usually made of sufficient strength to enable them to be used for low-pressure steam-heating. Ordinary cast-iron radiators are often used with steam of 25 or 30 lbs. pressure per square inch, and sometimes, indeed, with steam direct from high-pressure boilers working at 50 lbs. pressure; but I strongly object to putting them to such severe tests, and certainly do not consider that more than 5 lbs., or in exceptional cases 10 lbs. pressure per square inch, should be used in private houses. Throughout the following description, it may be taken that steam of about 5 lbs. pressure is alluded to. Boilers for steam-heating should never be built of cast-



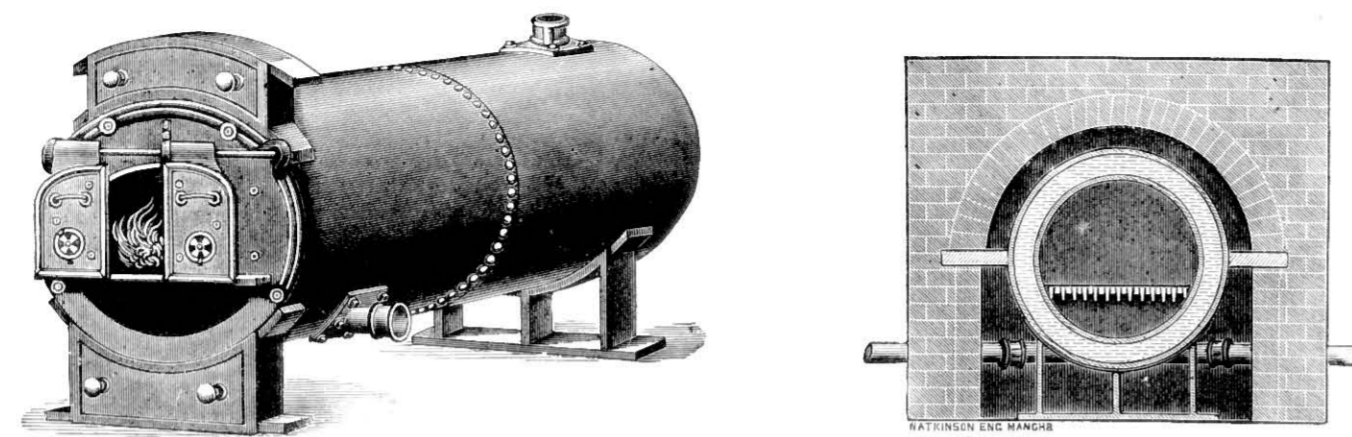
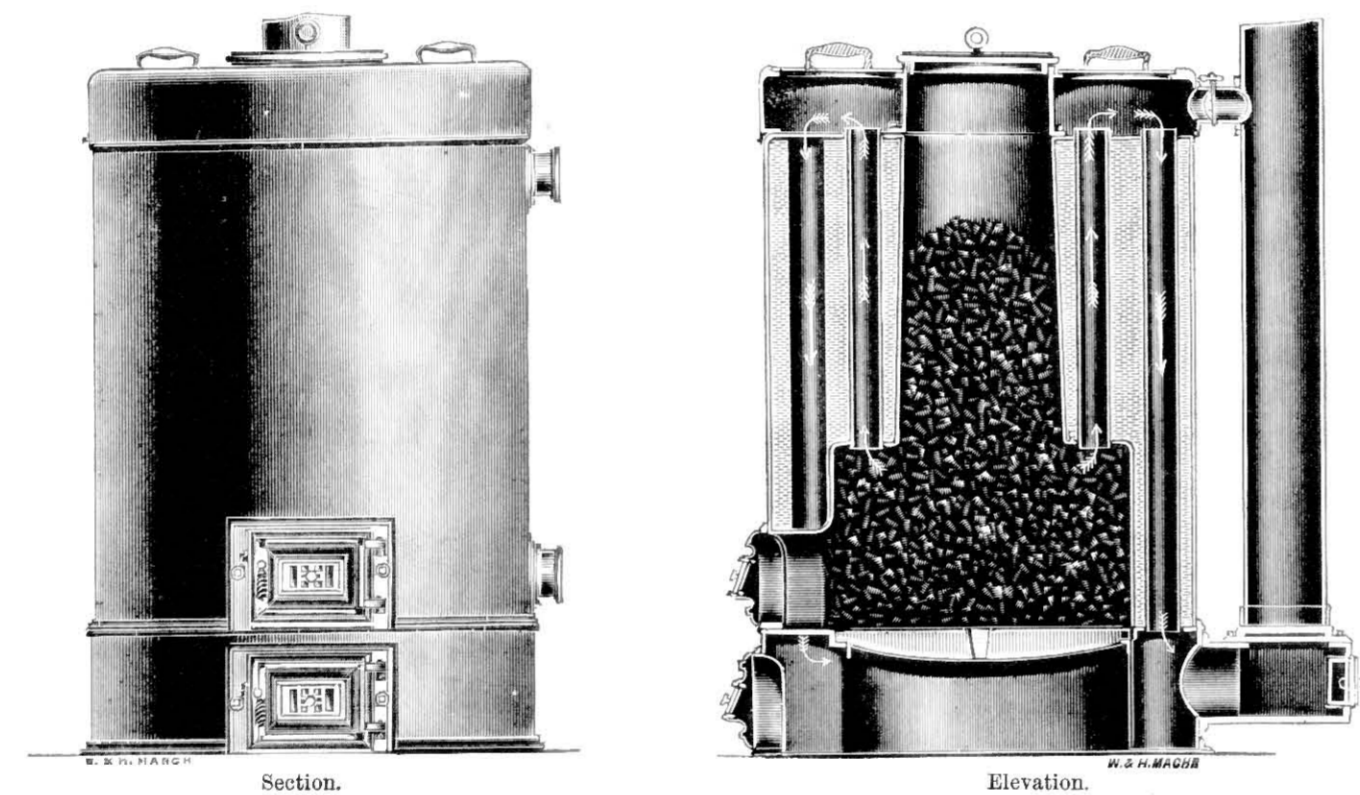

Fig. 546.—View and Cross Section of the "Trentham" Cornish Boiler.

iron. They should have ample steam and water spaces. I consider that no type



of boiler is so suitable for this work as the ordinary Cornish boiler, that is, a boiler with cylindrical shell and one cylindrical flue, with or without cross tubes, and set in fire-brick with proper side flues. Such a boiler is shown in fig. 546. The grate is inside the furnace-flue, and the products of combustion go from the flue down underneath the boiler, so that the

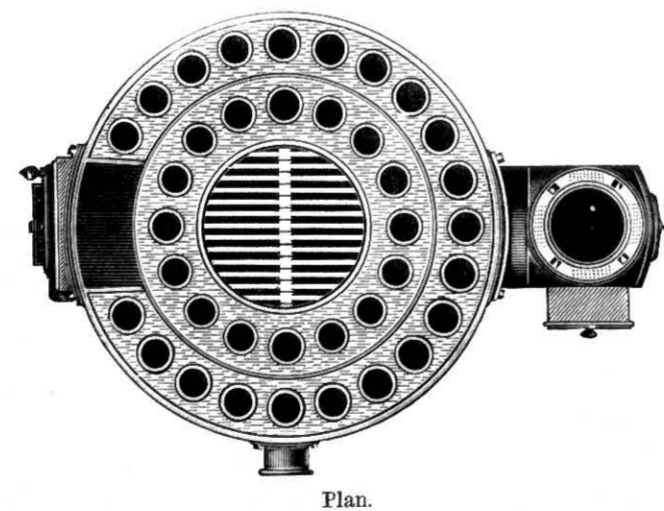
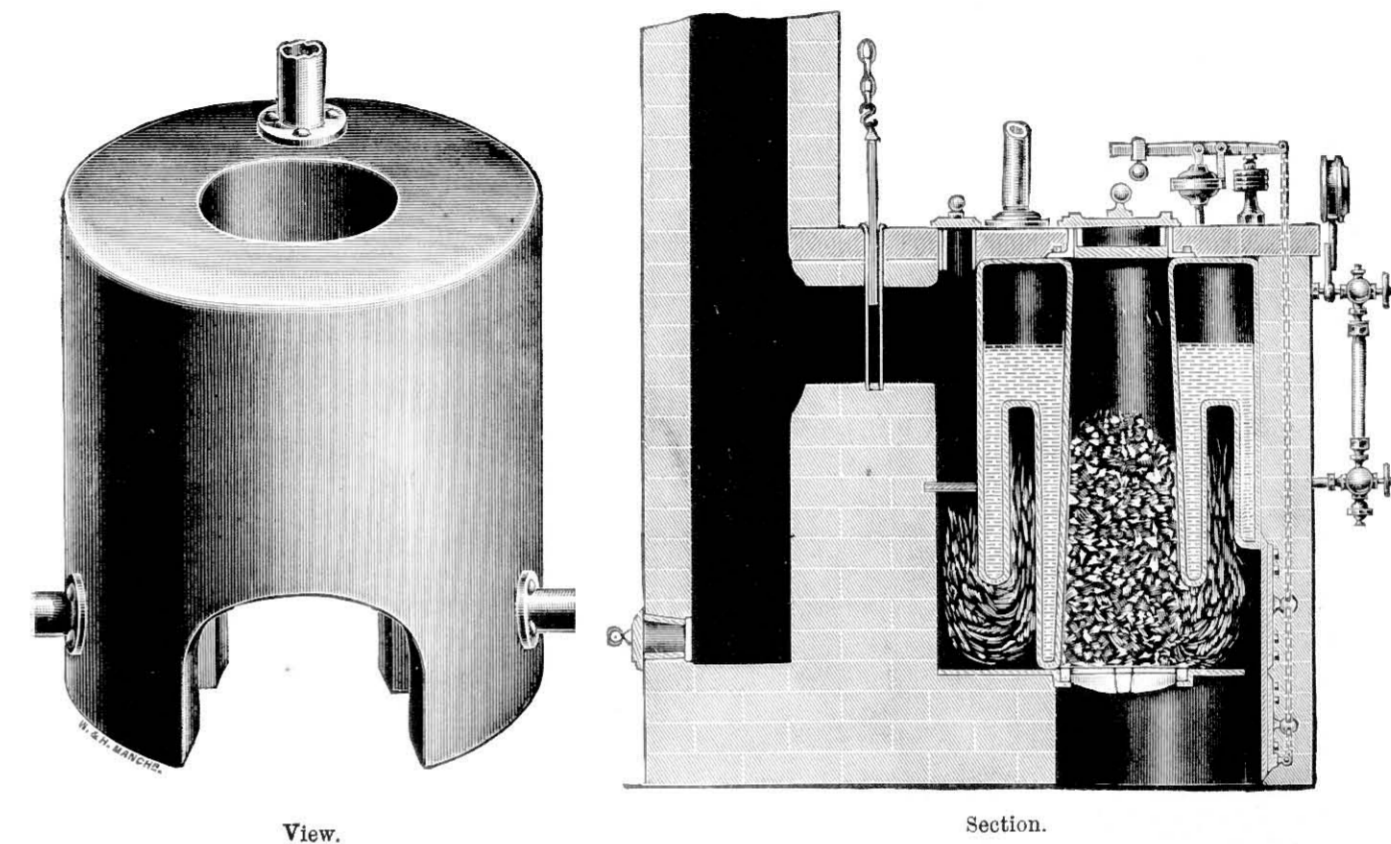

Fig. 547.—Elevation, Section, and Plan of the "Majestic" Independent Boiler for Steam-heating.

bottom of the boiler receives the hottest gases, and then the draught is split, and the gases pass along the sides and go out into the chimney-stack. Some people, however, prefer to use the saddle type of boiler, with a much deeper crown than in the case of the hot-water boiler, or a waggon boiler, but both these



types are, in my opinion, inferior to the plain Cornish boiler.

In some cases it is very desirable that brickwork should be avoided; a vertical type of boiler should then be used, such, for instance, as that shown in fig. 547. This type has the very important advantage that it possesses a central fuel-hopper, so that a considerable charge of coal can be put on at once, and the boiler will not require so much attention. It is arranged with a ring of vertical flue-tubes, through which the products of combustion rise, and also with a second ring of tubes, through which they descend; these tubes are surrounded by the water, so that an

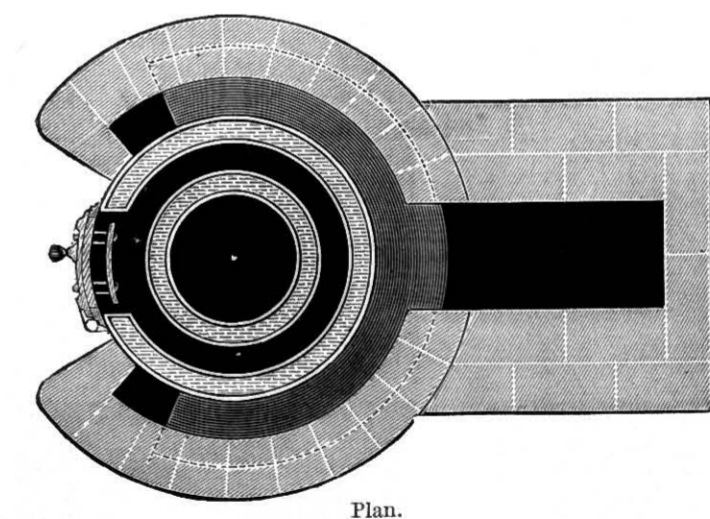

Fig. 548.—View, Section, and Plan of the "Caloric" Boiler for Steam-heating.



efficient heating-surface is obtained. A good steam-space is also provided, which is important, as it is very desirable that dry steam should be obtained.

A neat little boiler, which, however, requires brick-setting, is shown in fig. 548. This has also a central hopper for receiving the fuel, and therefore will require less attention than if the door on a level with the grate were the sole means of stoking. The products of combustion pass up into the water-space in an

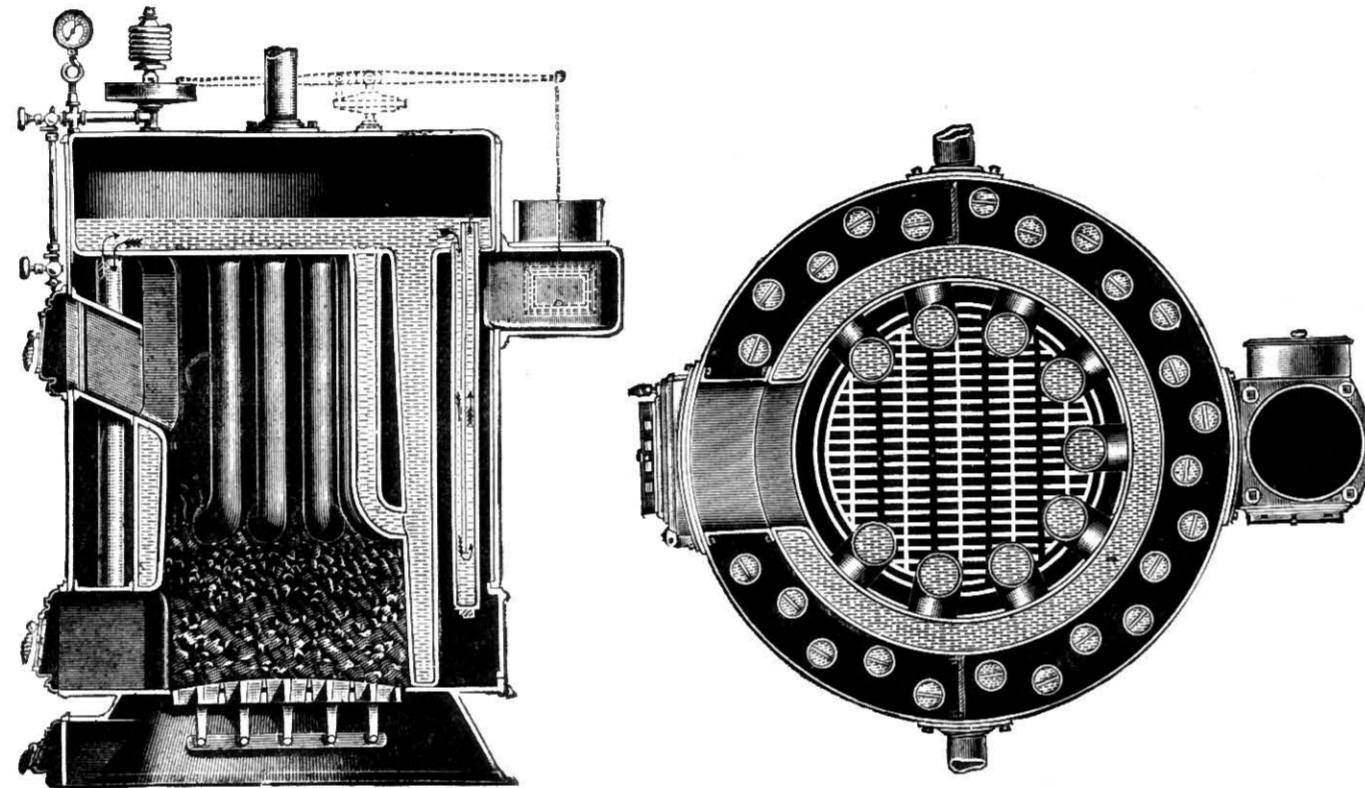

Fig. 549.—Section and Plan of Lumby, Son, and Wood's Patent "Pioneer" Boiler.

annulus before going out to the chimney-stack. One outlet-pipe is provided, and one inlet, although two inlets are shown in the illustrations.

A boiler of somewhat novel construction is shown in figs. 549 and 550, and is known as the "Pioneer" independent boiler. As will be gathered from the illustrations, it consists of outer and inner cases, and of a series of water-tubes. It is made in sizes varying in height from 54 to 82 inches; the smallest size is said to be capable of heating 600 square feet of actual radiating surface, and the largest 1750 square feet. These boilers are made of Siemens mild steel plates welded together, and are fitted with safety-valve, water-gauge, and pressure-gauge. It may be remarked in passing that a very similar boiler is made for low-pressure hot-water heating, but in this case the water of course fills the boiler completely.

Every boiler, no matter how small, should be provided with the following fittings:—Two safety-valves (one of the lever type, loaded so as to blow off at, say, 5 lbs., and the other a dead-weight safety-valve which cannot be tampered

with, and loaded to, say, 7 lbs. pressure), a reliable pressure-gauge of the Bourdon type, made by some well-known maker, and a water-gauge, so that the level of the water in the boiler may be easily observed. There should be a mark upon the gauge, or a brass pointer should be fixed upon the boiler-casing, showing the proper working-level of the water, so that the attendant may observe instantly if the water is getting too low. If this were to occur the crown of the firebox would become dry, and might become red hot. Fusible plugs are often inserted to guard against such an occurrence, as the fusible metal contained in them melts out, and the water pours in upon the fire and extinguishes it.

Messrs. Körting Bros. have a special system of low-pressure steam-heating, which certainly deserves notice. The boiler itself is represented in figs. 517 and 518, pages 120 and 121. This system differs considerably in many points from the usual methods of heating by steam. Fig. 551 is an illustration of the general arrangement. G is the low-pressure steam-boiler, r the fuel-hopper and patent furnace, s the safety-pipe, v v the steam-distribution pipes, ss the coils or radiators to the rooms, v v the steam-admission valves, c c' c" the return-pipes for condensed water, A the air-pipe, w the syphon-pipe between the air and water vessels, R the syphon water-vessel with air-pipe, and R' the syphon air-vessel. The steam-generator, or boiler, which has already been described in detail upon page 121, is placed in the basement of the building, in as central a position as can be conveniently arranged. The steam generated, at a pressure of  $1\frac{1}{2}$  to 5 lbs. per square inch, is conveyed by the steam-distribution pipes v v to the radiators s s. The radiators, which are filled with air from which most of the oxygen has been absorbed, are placed upon the various floors, so that they stand as far as possible in series one above the other, and, where this can be arranged, they have joint condensed-water return-pipes c c, falling vertically to the basement, where they are collected into a common main return-pipe at the floor-level. A further connection is made from each radiator to the air-collecting pipe A, which is carried under the ceiling of the basement, and connected to the air-vessel R', and also by means of a "drain-pipe" c, to the main return-pipe

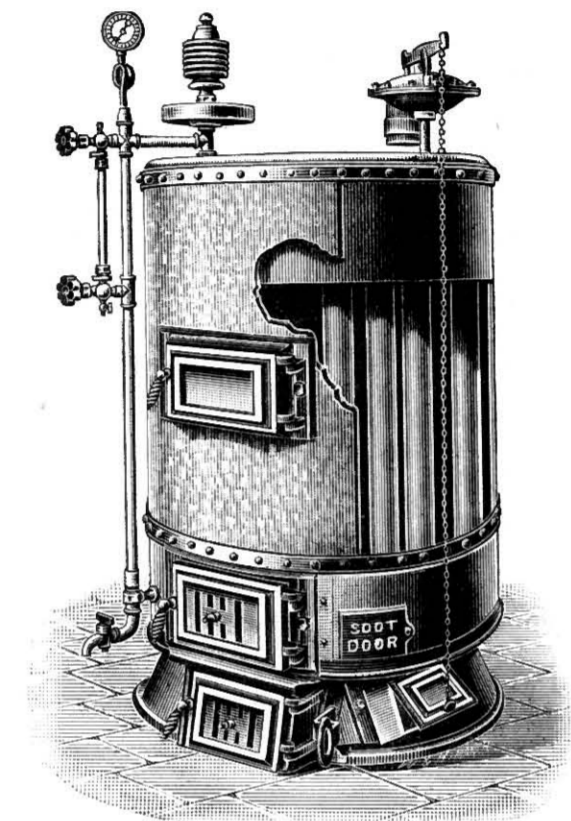

Fig. 550.—View of Lumby, Son, and Wood's Patent "Pioneer" Boiler.



on the floor. The air-vessel  $R'$  is joined by the syphon-pipe  $w$  to the water-vessel  $R$ , and as this latter has a pipe open to the atmosphere, it is in consequence always under atmospheric pressure. The capacity of each of the two

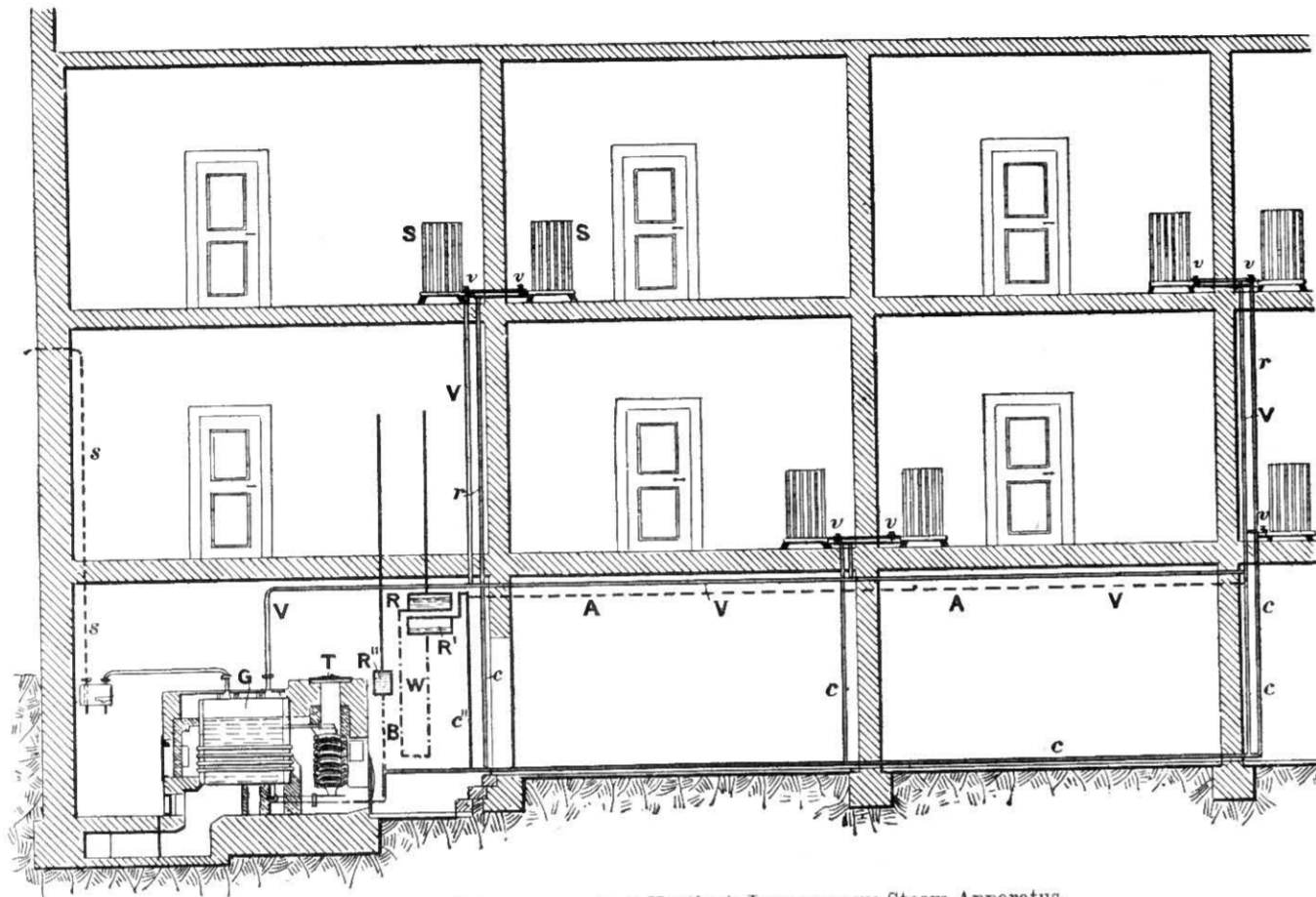

Fig. 551.—General Arrangements of Körting's Low-pressure Steam Apparatus.

A, air-pipe;  $c$   $c'$ , return-pipes for condensed water; G, low-pressure steam-boiler; R, syphon water-vessel with air-pipe;  $R'$ , syphon air-vessel;  $s$ , safety-pipe; S, coils or radiators in the rooms; T, fuel-hopper and patent furnace;  $v$ , steam-admission valves;  $v'$ , steam-distribution pipes; W, syphon-pipe between air and water vessels.

vessels,  $R$  and  $R'$ , is equal to the total cubic contents of the radiators, the steam connections, and the steam-space of the boiler.

The working of the apparatus is quite simple. The boiler  $G$ , and the syphon air-vessel  $R'$ , are filled with water to the required level, and as soon as steam is generated in the boiler, the air, occupying the steam-space of the boiler and distribution-pipes  $v$   $v'$ , is displaced by the steam and driven through the radiators into the vessel  $R'$ , displacing in turn the corresponding volume of water from this vessel, and driving it into the vessel  $R$  through the syphon-pipe  $w$ . Each radiator has a specially-constructed steam-valve, as shown in fig. 552. The valve has an indicator, and by reference to this the degree to which the valve is opened may be ascertained, and accordingly as the valve is more or less opened, more or less air will be forced out of the radiator into the vessel  $R'$ . If the regulating-valve be quite closed, the steam in the radiator will quickly condense, and the radiator will again fill with air from the vessel  $R'$ .

The advantages of this system are considerable. The air in the heating-system cannot escape, as it is trapped on the one side by the water in the boiler, and on the other by the water in the vessel  $R$ , and therefore no fresh air from outside is taken into the system. This fact is of the greatest importance, as the air, hermetically inclosed in the system, loses its oxygen in a very short time, and ceases to have the slightest corrosive action upon the inside of the pipes and radiators. Air-valves are not required, and the regulation of each radiator can be effected perfectly and easily by one steam-valve. The heating may be carried on either continuously or with breaks, as may best suit the character of the building, the season of the year, or the preference of the owner. As all the connections which contain water when the heating is out of use are without exception in the basement of the building, the risk of freezing is very slight indeed, and damage to the radiators and pipe-connections above the basement from this cause is quite impossible. The water-level in the boiler is not subject to any variation during working, as all the condensed water is returned direct by gravitation, and perfect noiselessness of working is secured, if the steam and water never come into direct contact with one another in the pipes.

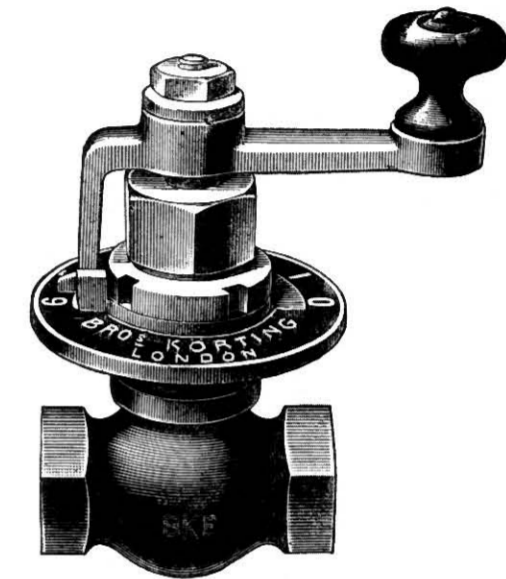

Fig. 552.—View of Steam-valve.

The maintenance of a constant pressure is of special importance in low-pressure steam-heating, and the inventors of this system have designed an automatic draught-regulator (shown in fig. 520, page 122), by which this is secured.  $Q$   $Q_1$  are vessels containing mercury,  $D$  is the steam connection to the boiler,  $w$  the water-connection to the stand-pipe,  $s$  a float,  $H$  the lever arm,  $F$  a movable weight, and  $v$   $v_1$  valves for regulating the admission of the air. The action of the regulator depends upon the change of level of the surface of the mercury in the vessel  $Q$ . The upper part of this vessel is connected by the pipe  $D$  to the boiler, and the mercury rises and falls as the variation of the steam-pressure in the boiler causes the movement of the float  $s$ , which works the lever  $H$ , on the ends of which the double valves  $v$  and  $v_1$  are suspended. When the pressure in the boiler rises to a certain height, the valve  $v_1$ , which regulates the air-admission to the furnace, commences to close, and the valve  $v$ , which allows air to pass by a second canal in the boiler-setting direct into the flue, begins to open. When the maximum pressure desired is reached, the valve  $v_1$  is completely closed and the valve  $v$  fully opened, so that the fire is deadened and



does not again burn briskly, until the reduction in steam-pressure has resulted in the sinking of the float *s*, and the consequent alteration of the position of the valves *v* and *v*<sub>1</sub>.

An improvement has been made in the regulator by the introduction of the movable weight *F*. By altering the position of this weight, the valve *v* and the float can be nearly balanced, and it is possible to obtain a constant pressure of from  $4\frac{1}{2}$  lbs. down to 0.15 lbs. per square inch. It is thus possible during the night, or at intervals when the heating is not required, to lower the pressure, thus causing the coils in the various rooms to be partly filled with air, and thereby reducing the fuel-consumption during this time to a minimum. When heating is again required, the weight is moved, and the steam-pressure rises; the air is forced out of the coils, and the rooms are warmed without anyone in the rooms troubling in the least about it. The heating of all the rooms is in this way under full control from the boiler-house.

Although, in ordinary working, **an excessive rise in the steam-pressure** is prevented by the draught-regulator, it is conceivable that, by some accident, such an increase may occur. The steam-pressure would then force the water out of the syphon in the stand-pipe; the steam would escape, and the pressure would altogether disappear. In such a case the pressure on the mercury in the regulator would also cease, and owing to the consequent sinking of the float, the air, which had been kept from the furnace by the closed valve *v*<sub>1</sub>, would be admitted again, and there would be risk of burning out the boiler. The regulator is, however, so designed that all such risk is prevented. There is a second vessel *Q*<sub>1</sub> containing mercury, connected by a small pipe *w* to the upper part of the stand-pipe. Should the water blow out of the syphon, part of it flows out of the stand-pipe into *Q*<sub>1</sub>, which is thus under water-pressure equal to the height of the stand-pipe. As this pressure is at least as high as the maximum steam-pressure needed to work the float, this will maintain the float in the position in which air is cut off from the furnace, until the water in the pipe *w* is allowed to run out through the valve *E*, fig. 519, page 122.

I have entered at some length into a description of Messrs. Körting Bros'. special system, because I consider that their **method of dealing with the air and condensed water** is extremely ingenious. In examining steam-heating plants, one observes constantly that the air-cocks are placed at the top of the radiator coils, either through carelessness, or because the designers do not realize that air is heavier than steam; the result is that air-cocks are opened, and steam is seen escaping, and they are at once shut upon the assumption that no air is present in the coil. The heating is not found very satisfactory, the reason being that

there is always a stagnant body of air at the lower part of each radiator, and this is very difficult to heat to the temperature of the steam. Quite elaborate arrangements of pumps are also provided in order to get the condensed water back into the boiler, although, as already pointed out in describing this system, the whole of this work can be done by gravitation if the scheme is only properly designed.

Messrs. Körting Bros. also state that, for their low-pressure steam-heating, they use as far as possible **radiators** which, according to their latest invention, are not filled with steam alone, but with a mixture of air and steam. Formerly when the steam was admitted to the top of the radiator, it pushed the air partially or entirely out, but steam being lighter than air, the result was that, when not worked to their full capacity, the top of the radiator was actually heated to the full temperature of the steam, while the bottom being full of air, remained cool. Now the steam is admitted by a special arrangement to the bottom, and the steam and air rise and circulate through the radiator, warming the whole of the surface to a lower or higher temperature according to the temporary requirements. The inventors of the system claim that the radiators, although warmed by steam, give the same agreeable heat as low-pressure warm-water coils, without having the disadvantages of that system, and especially without the disadvantages of freezing in winter. Of course the steam-pipes are relatively smaller than hot-water pipes calculated to do the same work, and therefore cost less.

In the chapter on low-pressure hot-water heating, I have described a number of forms of radiators, most of which are equally suitable for steam; the only point to be borne in mind is the position of the air-cocks. The inlet and outlet pipes for steam will also be smaller, and if stock-pattern radiators are bought, it will be necessary to use a nipple to reduce the size of the opening. Messrs. Körting Bros. make a type of radiator with specially thin gills, which is very cheap, and also gives a very large surface for the radiation of heat. Two varieties are shown in fig. 553, the square and the oval. These are solidly constructed, but are not of sufficiently artistic appearance to be used in living-rooms without some kind of ornamental case, which may be either of cast iron or wrought.

The inventors of the system, which has here been fully described, lay down **the following principal requirements**, which should be fulfilled by a low-pressure steam-heating apparatus, and claim that their apparatus fulfils them:—

- (1) There must be complete control of the temperature of the rooms heated.
- (2) The coils or radiators ought to be below 212° Fahr., as at higher tem-



peratures the small particles of organic matter, which float in the air in the form of dust, are volatilized when coming into contact with the heating-surface, and disagreeable and unhealthy smells result.

(3) The steam-generator must be constructed so as to secure continuous and

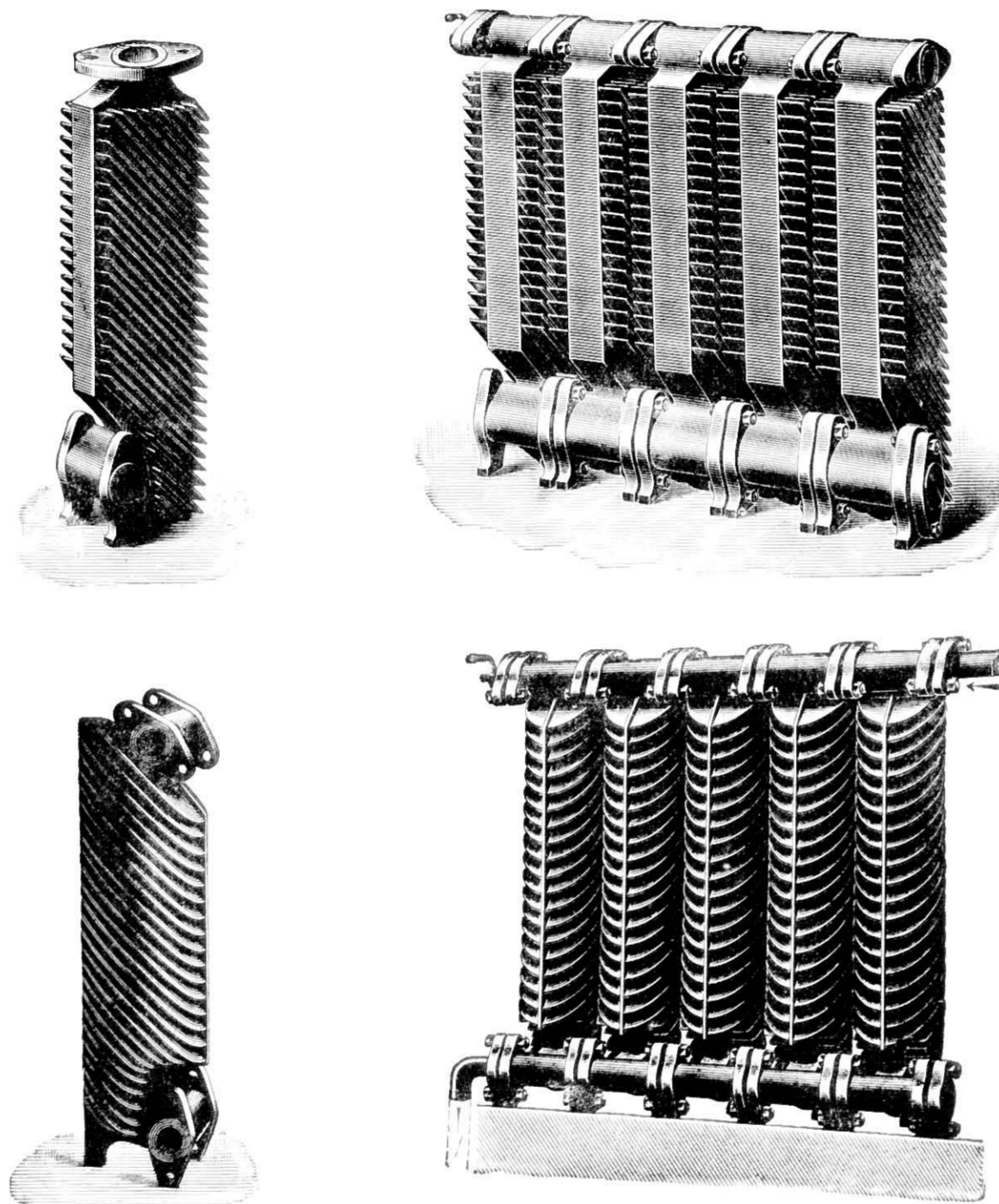

Fig. 553.—Views of Körting's Radiator, Square and Oval Patterns.

efficient combustion of the fuel, to avoid the inconveniencing of the neighbourhood by the emission of smoke, and to prevent any formation of clinker in the furnace. Further, there should be no liability of damage to the generator owing to possible neglect.

(4) The consumption of fuel must be automatically regulated to suit the

variation in the demands on the heating-surface in the rooms, so that the actual weight of fuel burned in the furnace in a given time is proportionate to the amount of heat passing into the rooms from the heating-surface.

(5) To minimize the attendance, the steam-boiler must have a furnace-hopper of such capacity as to contain fuel sufficient at least for the night, so as to dispense with night attendance, and also to secure that the fuel only needs replenishing at lengthy intervals during the day.

(6) Any portion of the heating-system, which may be liable to exposure to frost, must be quite free from water, when the heating is not in operation.

(7) There must be no liability to rusting, either on the inside or the outside of any part of the heating-system.

**Lap-welded wrought-iron pipes**, of what is known as "steam quality", should be used, with wrought-iron elbows, tees, bends, &c., throughout. Cast-iron pipes are not suitable for use with steam. The supports for the pipes will be of a smaller and simpler kind than those needed for hot-water work, and generally the whole of the pipes will be of smaller size and will be found much easier to run in confined places; these small pipes can readily be taken behind skirting-boards and in other similar positions, where it might be difficult or impossible to fix hot-water pipes.

The stop-valves used in this work will require to be of a different type. In preference to the "Peet" valve, I use such a valve as that made by Messrs. Dewrance of London with a renewable seating, and illustrated in fig. 554; these cocks have a good seating, and will last a very long time. For the smaller sizes, say up to 2 inches, they are made of solid gun-metal, and in a house it is scarcely likely that valves larger than these will be required. For the condensed-water pipes, a valve such as the Peet valve may certainly be used, as it affords a full way, which is of some advantage. The whole object in hot-water work, in fact in water work of any kind, is to afford as full an opening as possible, and to change the direction of flow as little as possible, as change in direction means added friction. For steam, however, a slight change in direction makes no difference, but it is essential to obtain a good seating for the valves. In a low-pressure steam-heating plant, there will be less energy



Loose valve attached to end of spindle by a nut.



Seating screwed into valve body.

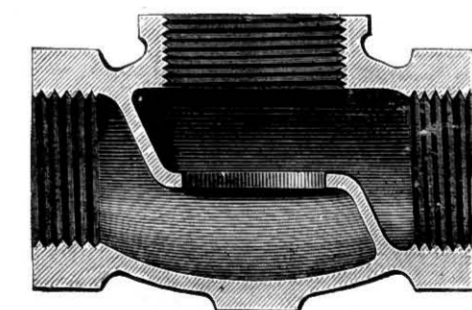

Fig. 554.—Dewrance's Renewable Valve.



expended in friction in the pipes themselves than in a hot-water apparatus, as in the latter case the medium is a fluid and in the former a gas.

---

## CHAPTER VII.

### GENERAL CONCLUSIONS.

I consider **the system of open fires** of coal or wood to be by far the most healthy of all the systems which have now been described; and, with due attention to the methods by which the consumption of fuel can be diminished, while greater efficiency in the use of the fuel is obtained, I do not see that it can well be improved upon for private houses in the British Isles. It is, however, desirable that a special supply of air should be brought to the fire from outside wherever possible.

Where it is desired to use **some auxiliary system**, then I consider that low-pressure hot-water is, taking it all round, the most suitable for general use, as being perfectly safe and requiring little attention. I do not consider systems of heating by heated air desirable, if they are to be used instead of fires, but as auxiliary means of providing general warmth, they may be of service; the chief objection in my mind to the use of heated air is, that it is necessary to breathe the heating medium, whereas the ideal to be aimed at is to heat the objects, the walls, and the persons in the rooms, while leaving the air comparatively cool for breathing. Systems of steam-heating and high-pressure hot-water heating have their uses as auxiliary means of heating, and are specially to be recommended where it is desirable to occupy as little space as possible with the pipes.

**Close stoves and close fireplaces** are, in my opinion, not to be recommended in preference to open fires, except upon the basis of lower financial cost of maintenance. The cold of the British winter is not usually so severe as to call for such means of heating, and although perfect smokelessness can be obtained by the use of some of these apparatus, yet the smoke can so far be diminished by the use of suitable open grates that they cease to be very objectionable in this respect.

**Gas-fires** are not, in the author's opinion, desirable, as there is usually a smell produced by them; if the register is not very carefully adjusted, either most of the heat disappears up the chimney, or, on the other hand, invisible

products of combustion, in the form of carbonic acid gas, &c., are discharged into the apartment.

In closing, I would say again that it is desirable to warm the whole of the house and not a mere part of it, and to prevent draughts by arranging for special inlets and special outlets of the air, and this can be done perfectly in the case of new buildings, although probably with only partial success in the case of buildings already completed.



SECTION XI.  
WARMING AND COOKING BY ELECTRICITY

BY

E. A. CLAREMONT

MEMBER OF THE INSTITUTE OF ELECTRICAL ENGINEERS; MEMBER OF THE INSTITUTION OF  
MECHANICAL ENGINEERS; AUTHOR OF "ELECTRIC LIGHTING", ETC.





## SECTION XI.—WARMING AND COOKING BY ELECTRICITY.

---

Before entering upon a discussion of the merits and demerits of the utilization of electricity as a means of producing heat, either for cooking or warming, it would be well to consider the causes which have led to its adoption. Let us then, for a moment, consider **the means usually employed for cooking** in the kitchen of an ordinary home, *i.e.* the use of coal in an open range. The efficiency of such a method in the case (say) of roasting before the fire, is usually considered to be as low as from 10 to 15 per cent of the heat produced, and when we consider that the remaining percentage is either actually lost by going up the chimney, or is spent in making it generally uncomfortable for the cook, we feel that we have hardly got value for our fuel. Some slight improvement has been obtained by enclosing coal-fires in stoves. But even they, although not allowing the heat of the room to become excessive, still permit an enormous waste in the shape of hot air going up the chimney.

Another method of cooking very much in vogue consists in the use of gas-stoves. Careful experiments, however, have shown that, although obtaining a much higher efficiency than coal, with the additional advantage of no surrounding heat, about four-fifths of the total heat generated is, in the case of roasting, uselessly dispersed. In addition to this, food cooked over gas frequently has a disagreeable flavour, while the stove, even if it has ventilators attached, almost invariably gives off a quantity of noxious gases,—sometimes that known as “acetylene”,—which are the direct cause of the headache, which usually comes on after entering a room in which a gas-stove has been burning.

**A good cooking-apparatus** should, in addition to being of moderate cost while actually in use, possess the following advantages:—1. No smell; 2. No external or radiant heat; 3. No generation of noxious vapours; 4. The quality of being able to be turned off or quenched, either partially or wholly, as cooking



proceeds or ends. These advantages, especially the last, may appear at first sight to savour somewhat of Arcadia, but, as I hope presently to point out, not only are they to be obtained, but are now actually within reach of the ordinary householder, by means of electricity.

A very popular impression seems to be that electricity, in its commercial form, can give no heat. So far, however, is this from being the case, that it is at present utilized to melt and weld metals which cannot be affected by other methods. This idea has no doubt arisen from the fact that buildings lighted by electricity are quite cool, when compared with those lit by other illuminants; the reason of this, however, is that electricity employed to give light yields such extraordinary brilliancy when compared with the actual size of the illuminating space, that such space, though in itself extremely hot, conveys hardly any additional heat to the surrounding atmosphere.

The theory upon which electrical heating is based is very simple. The reader is doubtless aware that all generators of electricity require an external circuit or path. In this path the work to be done invariably lies, whether it be in the shape of lighting, power-transmission, or any other means of absorbing electrical energy. The easier this path becomes, the greater is the rush of current down it; hence, as some metals are known to conduct the current with much greater ease than others, we say that they offer less resistance. To understand this aright, let us compare the flow of electricity along a wire with the flow of water in a pipe. We know that, with a certain head and pressure of water, a large pipe will allow an easy flow, while a small one will necessitate the forcing of the water through it with considerable difficulty. Electricity in a wire acts in a somewhat similar way; when the current is large and the conductor small, the latter becomes hot, owing to the resistance offered. Different metals, however, offer different degrees of resistance; thus, if we substitute an iron for a copper wire, the iron, although perhaps of exactly the same diameter as the copper, will get hot with the same current that the copper was able to conduct without heating. This fact—that resistance to a current produces heat—is the basis of cooking and warming by electricity.

The next point to be considered is, **how this heat can be produced without allowing any to escape.** We have already seen that the wires, by whose agency heat is to be produced, must be of high resistance; but few metals capable of offering this high resistance can withstand any great degree of heat, especially when exposed to the atmosphere. The commoner metals, otherwise most suitable, generally oxidize when subjected to an unusual degree of heat. The only method of preventing this oxidizing is so to enclose the resistance-wires that

the atmosphere cannot get at them; if such enclosure is perfect, the commoner metals may be used with impunity.

**Resistance-wires used for heating-purposes** are generally wound in spiral coils, as a great length of metal, and so of heating-surface, can thus be packed in small compass. Strange though it may seem, more difficulty has been experienced in obtaining an air-tight jacket for the coils than in perfecting the electrical part of the apparatus. The great difficulty was to find a composition which, while admitting no air, was capable of expanding, when heated, exactly in an equal ratio with the wires it enclosed. It will be seen that, given some such suitable compound, heat generated in the enclosed coils could, through contact with the compound, be much more readily conveyed to any pan or dish placed on it than if this were merely held over hot wires. And not only that, but such unprotected wires would be a constant source of danger from the possibility of a short circuit being formed. By a "short circuit" is meant a more direct path, and may be illustrated by a pan placed on two resistance-springs, through the total length of which the current would, in the ordinary course of things, be made to flow; the pan, being also of metal, would offer a much shorter circuit for the current than the many convolutions of the springs, and would, by thus allowing the electricity to bridge across, cause the springs, or that part of them short circuited, to become dead, and so lose the heat they possessed. The composition, therefore, must not only possess certain ratios of expansion, and be impervious to the passage of air, but it must also be made of insulating material; that is, of a material of the very worst conducting capacity, so that a short circuit cannot possibly occur through contact with the compound itself.

In the earlier experiments with heating-resistances, cement of different kinds was largely used, but owing to its breakable and porous nature, air very soon got to the wires, oxidation set in, and the apparatus became useless. The material in most frequent use now is a kind of enamel, which while possessing the necessary qualities mentioned above, is also a good conductor of heat, and is capable of adhering firmly not only to the wires imbedded in it, but also to the hot-plate to which the warmth is to be conducted. It will at once be seen that heat obtained by conduction is, for cooking, far superior to that due to radiation only.

**The wires can be built in any shape** to suit the requirements of the article to be heated, thus preventing the great loss of energy usually expended in uselessly heating the surrounding atmosphere; and not only this, for in the case of light goods, such as kettles, flat-irons, &c., the heating-springs are actually built into the article itself, thus not only doing away with the atmospheric



medium, but giving only one intervening plate to be heated, instead of at least the two used in the case last mentioned.

On coming into a kitchen where an electric oven is in use (see fig. 555), we are at once struck with the great difference between its surroundings and those pertaining to the old-fashioned range. Among the things which have disappeared are the smell of smoke, the risk of falling soot, and the high surrounding temperature due to keeping up a large fire for an hour or two

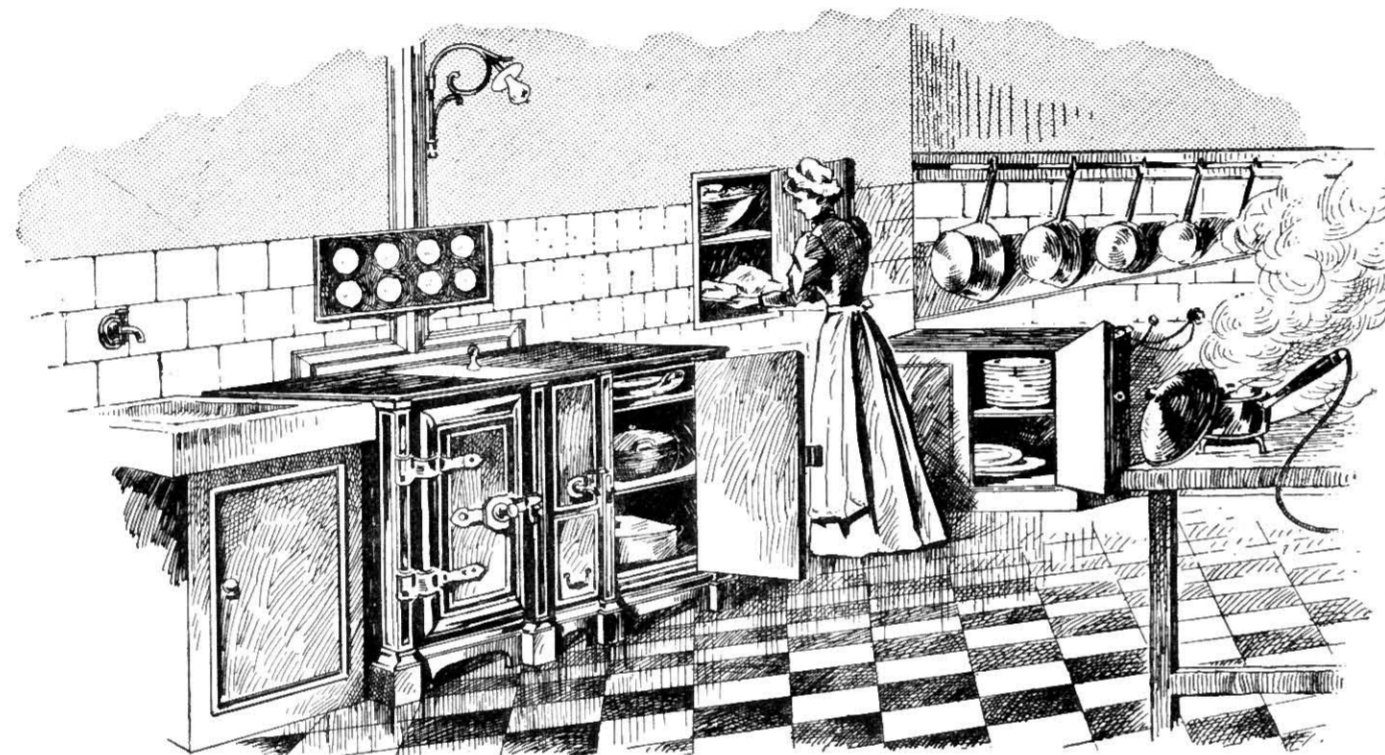

Fig. 555.—An Electric Kitchen.

before the oven is required in order to attain the necessary degree of heat; and there is no risk of finding that one side of the oven has been nearly red-hot, and has charred the eatables on one side, while the other is unbaked; or that the fire, not having been regulated with sufficient nicety, has either burnt the eatables or left them quite uncooked; for, by the peculiarities of construction above referred to, not only can we surround an electric oven with heating-surfaces on all sides, top or bottom, but, by merely turning the handle of a switch, we can regulate the current passing through these heating-surfaces, and consequently the degree of heat which any part of such an oven may attain, as shown in fig. 556. Thus, in an oven with six switches, all can be turned on to bake a certain article, and if this is not immediately required, all but one may be turned off, the remaining one being capable of keeping it warm. When we consider also that such an oven can attain its fullest heat in about 10 or 15 minutes after being first switched on, and can be turned out im-

mediately after use, we can at once see that the efficiency of electricity used in this direction is very high, and the cost consequently low; on the other hand, as all unnecessary heat is waste, the burning down of a coal-fire after use in cooking is dead loss. Nor is the evil of loss up the chimney only confined to the householder bearing it, for, as anyone living in a large town may see, it is these small contributions, and not those from mills and workshops, which make the atmosphere in all great centres what it is, ruinous alike to health and property.

**Now as to cost.** The energy will probably be obtained from an Electric Supply Co., for as electricity can be generated more cheaply on a large scale than on a small one, this is, at any rate with small consumers, the cheapest method of obtaining it. In Great Britain such an electrical supply is usually dear, as it has to be generated from steam, being usually about 6*d.* per unit.<sup>1</sup> In places where generating power can be had more economically, electrical energy is much cheaper; thus

in some parts of America, where electricity can be produced from large flows of water, we are assured that power will soon be distributed from house to house at a charge of  $\frac{1}{8}$ *d.* per unit. Nor is this report exaggerated, as we might at first suppose, for in some parts of Europe to-day, such power, also derived from water, is being sold for  $\frac{3}{4}$ *d.* per unit. We will assume that 4*d.* per unit is a fair standard on which to base our calculations, this being, I understand, the actual amount now charged by one of the corporate bodies in London, though it is much higher than that at which an ordinary large private installation could supply it. We find that in an electric kettle 1 lb. of cold

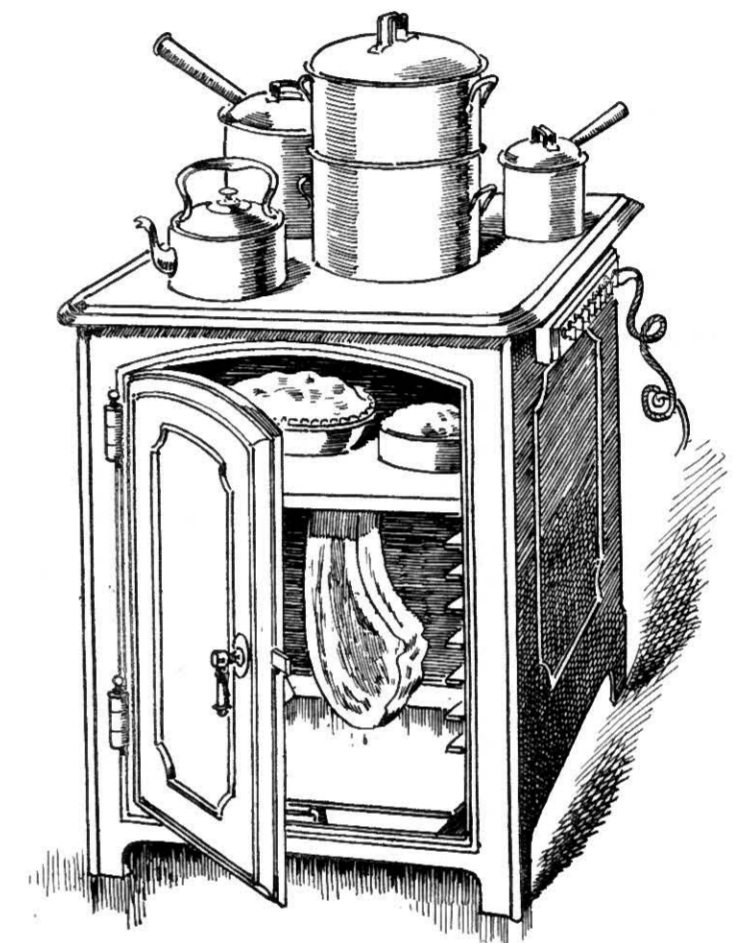

Fig. 556.—An Electric Oven.

<sup>1</sup> By an "unit" is meant 1000 "watt hours", a watt being the standard of electrical energy, obtained by multiplying the pressure (or "voltage") of the circuit by the current (or "ampère") absorbed by any particular apparatus; in other words, when the electrical energy, multiplied by the time in hours, equals 1000, an unit of electricity has been expended. The definitions of the terms used in connection with electricity will be more fully given in the chapters on Lighting by Electricity.



water can be boiled in approximately three minutes, with a current of 10 ampères at a pressure of 100 volts, which works out into units as follows:—

$$100 \text{ volts} \times 10 \text{ ampères} \times \frac{3}{100} \text{ hour} = 50 \text{ watt hours};$$

this, at 4*d.* an unit, works out thus—

$$1000 : 50 :: 4 : \frac{1}{5} \text{ of a penny.}$$

An oven like that illustrated in fig. 556 will, with a pressure of 100 volts, take a current of approximately 25 ampères for about  $\frac{1}{4}$  hour, by which time full cooking temperature of 325° to 400° Fahrenheit will be attained. After this first quarter of an hour a current of only 10 to 15 ampères will be sufficient to maintain this degree of heat.



Fig. 557.—An Electric Kettle.

Care should be taken in the purchase of cooking or heating goods that they are built to suit **the pressure of the consumer's circuit**, for such pressures vary, and it will readily be seen that applying current at too great a pressure results in more current being forced through than

it is capable of receiving without damage to it through overheating.

Small appliances, like kettles and other movable objects, usually get their connection by means of **two flexible silk-covered wires** in the form of a cord, at the end of which is a plug carrying two small metal terminals, which can be pushed into sockets fixed in different places on the wall for the purpose. This arrangement will be better understood by reference to the drawing of an electric fry-pan, shown in fig. 558. By means of the current supplied through these cords water can be boiled or kept boiling on the table where it is to be actually used.

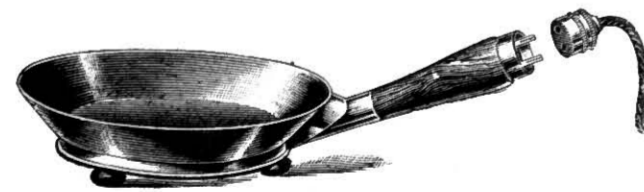

Fig. 558.—An Electric Fry-pan.

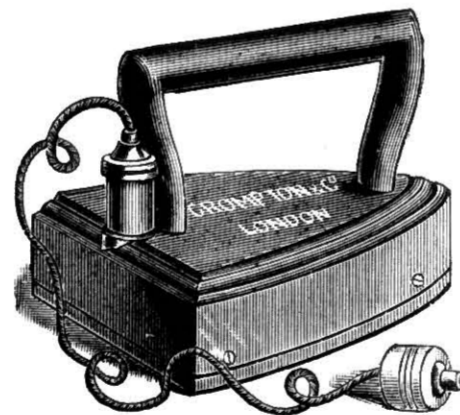

Fig. 559.—An Electric Flat-iron.

In the same way, flat-irons can be coupled by means of the flexible cord through which the current passes, and as the electricity warms the iron while in actual use, there is no necessity for heating more than one iron, hence there is a considerable saving in time and labour.

**Other portable objects**, such as curling-iron heaters, small radiators, cigar-

lighters, foot-warmers, &c., can be heated in a similar way, in any position in which they are most useful. One of the most striking instances of efficiency in this direction is given by the electrical foot-warmer, which consumes a current of one ampère only, which is little more than that taken by an ordinary incandescent light; with the unit at 4*d.*, such an arrangement in actual use would cost only  $\frac{2}{5}$ *d.* per hour.

**The efficiency of appliances** of this description may be said almost to be perfect, since kettles and similar utensils have an efficiency of 80 to 90 per cent, and hot-plate warmers have an efficiency of from 90 to 95 per cent. By using a grill arrangement of hot-plates similar to those just mentioned, a current of 5 ampères at 100 volts will, in about 10 minutes, raise the apparatus to cooking-heat, while another 10 minutes, at a slightly reduced current, will be sufficient to cook two chops, which will thus be done at an expenditure of less than 1*d.*, an amount which in many cases will hardly cover the cost of the chips used in lighting a coal-fire in an open range. Such an example, however, does not show the electric grill in its best light, as operations began with everything cold; if we continue to cook chops on the grill when the first two are finished, we shall find that the outlay will be less than  $\frac{1}{2}$ *d.* per couple.

It will be manifest that **heating is almost identical with cooking**, both as regards appliances and cost. The only necessity is to convert the hot cooking-plate into something possessing a more artistic appearance, and then call it a radiator.

**Electric radiators** are made in any shape, from the small ornamental one for the drawing-room to the long ungainly appliance used in schools or public buildings. Their utility is manifest; not only do we do away with the necessary ills consequent on a hot-water system, such as a visit to the boiler late at night to see that it is banked, leaks, smoke, &c., but we remove the danger from fire usually accruing from the use of these appar-

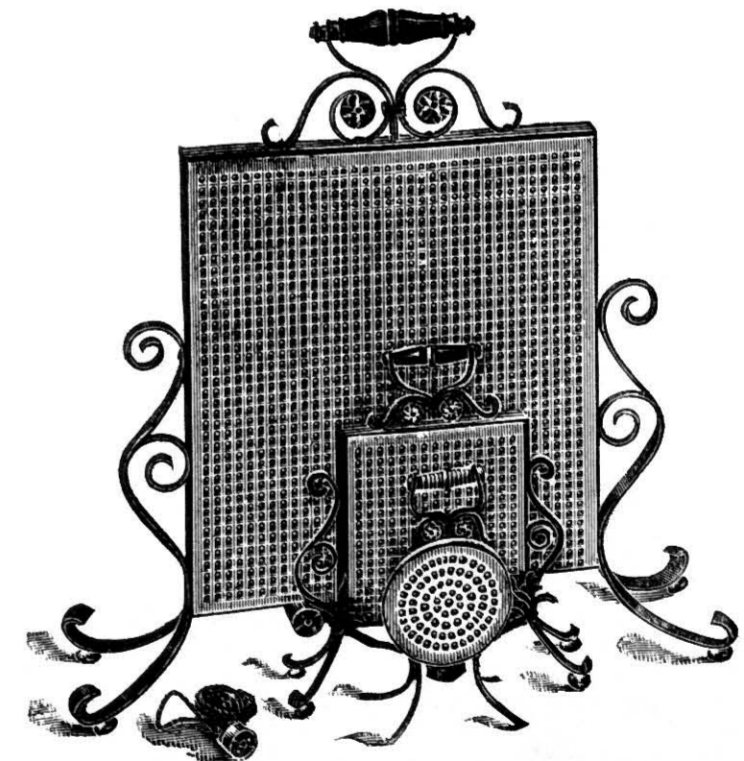

Fig. 560.—Electric Radiators.

atus. In fact, when electric heating is applied to theatres or other crowded resorts, the additional safety gained, quite apart from the matter of trouble,



should in itself be its recommendation. An electric heating-installation has recently been fitted up at the Vaudeville Theatre in London, the "box" form of radiators being used; the temperature of the auditorium can be kept at a standard temperature of 60°, when the passages are only 40°, by the use of a current of 90-ampères, and at a cost of only three shillings an hour. A great point in favour of such an arrangement is that it only requires to be switched on very shortly before the theatre has to be used, and can be turned off at any time during or after the performance.

Radiators for private houses, instead of being built as fixtures, are usually made portable in the shape of screens, pendants, &c. These possess the additional advantage, by means of their flexible connection, of being moved about at will. Such a screen as the largest shown in our illustration, exposing a surface of about 9 square feet, would, at 200° Fahr., heat a room of 1350 cubic feet capacity. These radiators can attain any range of temperature from 200° to about 450° Fahrenheit.

**In the choice of heating-appliances**, it should be borne in mind that self-contained apparatus are much the more efficient; that is to say, those articles into the bodies of which the warming gear is actually built, as, for example, the oven shown in fig. 556.

**The more general application of electricity** to cooking and warming would, undoubtedly, purify the atmosphere and reduce labour, and thus not only tend to prolong life, but to make it pleasanter and easier.