

COLLINS' ELEMENTARY SERIES

BUILDING
TIMBER & IRON WORK

BOOK I

TEXT

SCIENCE AND ART

BUILDING TIMBER AND IRON WORK

COLLINS' ELEMENTARY SERIES

BUILDING
TIMBER & IRON WORK

BOOK I

TEXT

SCIENCE AND ART

COLLINS' ELEMENTARY AND ADVANCED SCIENCE SERIES,

Adapted to the requirements of the South Kensington Syllabus, for Students in Science and Art Classes, and Higher and Middle Class Schools.

ELEMENTARY SERIES,

Printed uniformly in Fcap. 8vo, fully Illustrated, cloth lettered, price 1s. each Vol.

1. PRACTICAL PLANE & SOLID GEOMETRY. By H. Angel, Islington Science School, London.
2. MACHINE CONSTRUCTION AND DRAWING. By E. Tomkins, Queen's College, Liverpool. 2 Vols.
- 3A BUILDING CONSTRUCTION—STONE, BRICK, AND SLATE WORK. By R. S. Burn, C.E., Manchester. 2 Vols.
- 3B BUILDING CONSTRUCTION—TIMBER AND IRON WORK. By R. S. Burn, C.E., Manchester. 2 Vols.
4. NAVAL ARCHITECTURE—SHIPBUILDING AND LAYING OFF. By S. J. P. Thearle, F.R.S.N.A., London. 2 Vols.
5. PURE MATHEMATICS. By Lewis Sergeant, B.A., (Camb.,) London.
6. THEORETICAL MECHANICS. By William Rossiter, F.R.A.S., F.C.S., London.
7. APPLIED MECHANICS. By William Rossiter, F.R.A.S., London.
8. ACOUSTICS, LIGHT AND HEAT. By William Lees, A.M., Lecturer on Physics, Edinburgh.
9. MAGNETISM AND ELECTRICITY. By John Angell, Senior Science Master, Grammar School, Manchester.
10. INORGANIC CHEMISTRY. By Dr. W. B. Kemshead, F.R.A.S., Dulwich College, London.
11. ORGANIC CHEMISTRY. By W. Marshall Watts, D.Sc., (Lond.,) Grammar School, Giggleswick.
12. GEOLOGY. By W. S. Davis, LL.D., Derby.
13. MINERALOGY. By J. H. Collins, F.G.S., Royal Cornwall Polytechnic Society, Falmouth.
14. ANIMAL PHYSIOLOGY. By John Angell, Senior Science Master, Grammar School, Manchester.
15. ZOOLOGY. By M. Harbison, Head-Master Model Schools, Newtonards.
16. VEGETABLE ANATOMY AND PHYSIOLOGY. By J. H. Balfour, M.D., Edinburgh University.
17. SYSTEMATIC AND ECONOMIC BOTANY. By J. H. Balfour, M.D., Edinburgh University.
19. METALLURGY. By John Mayer, F.C.S., Glasgow.
20. NAVIGATION. By Henry Evers, LL.D., Plymouth.
21. NAUTICAL ASTRONOMY. By Henry Evers, LL.D.
- 22A STEAM AND THE STEAM ENGINE—LAND AND MARINE. By Henry Evers, LL.D., Plymouth.
- 22B STEAM AND STEAM ENGINE—LOCOMOTIVE. By Henry Evers, LL.D., Plymouth.
23. PHYSICAL GEOGRAPHY. By John Macturk, F.R.G.S.
24. PRACTICAL CHEMISTRY. By John Howard, London.
25. ASTRONOMY. By J. J. Plummer, Observatory, Durham.

London, Edinburgh, and Herriot Hill Works, Glasgow.

ADVANCED SCIENCE SERIES,

Adapted to the requirements of the South Kensington Syllabus, for Students in Science and Art Classes, and Higher and Middle Class Schools.

In the Press, and in Preparation, Post 8vo, fully Illustrated, cloth lettered, Price 2s. 6d. each volume.

1. PRACTICAL PLANE AND SOLID GEOMETRY. By Professor F. A. Bradley, London.
2. MACHINE CONSTRUCTION AND DRAWING. By E. Tomkins, Queen's College, Liverpool. 2 Vols.
3. BUILDING CONSTRUCTION. By R. Scott Burn, C.E. 2 Vols.
4. NAVAL ARCHITECTURE—SHIPBUILDING AND LAYING OFF. By S. J. P. Thearle, F.R.S.N.A., London. 2 Vols.
5. PURE MATHEMATICS. By Edward Atkins, B.Sc., (Lond.,) Leicester.
6. THEORETICAL MECHANICS. By P. Guthrie Tait, Professor of Natural Philosophy, Edinburgh.
7. APPLIED MECHANICS. By Professor O. Reynolds, Owens College, Manchester.
8. ACOUSTICS, LIGHT AND HEAT. By W. S. Davis, LL.D., Derby.
9. MAGNETISM AND ELECTRICITY. By F. Guthrie, B.A., Ph.D., Royal School of Mines, London.
10. INORGANIC CHEMISTRY. By T. E. Thorpe, Ph.D., F.R.S.E., Professor of Chemistry, Andersonian University, Glasgow. 2 Vols.
11. ORGANIC CHEMISTRY. By James Dewar, F.R.S.E., F.C.S., Lecturer on Chemistry, Edinburgh.
12. GEOLOGY. By John Young, M.D., Professor of Natural History, Glasgow University.
14. ANIMAL PHYSIOLOGY. By J. Cleland, M.D., F.R.S., Professor of Anatomy and Physiology, Galway.
15. ZOOLOGY. By E. Ray Lankester, M.A., (Oxon.,) London.
16. VEGETABLE ANATOMY AND PHYSIOLOGY. By J. H. Balfour, M.D., Edinburgh University.
17. SYSTEMATIC AND ECONOMIC BOTANY. By J. H. Balfour, M.D., Edinburgh University.
19. METALLURGY. By W. H. Greenwood, A.R.S.M. 2 Vols.
20. NAVIGATION. By Henry Evers, LL.D., Professor of Applied Mechanics, Plymouth.
21. NAUTICAL ASTRONOMY. By Henry Evers, LL.D., Plymouth.
22. STEAM AND THE STEAM ENGINE—LAND, MARINE, AND LOCOMOTIVE. By Henry Evers, LL.D., Plymouth.
23. PHYSICAL GEOGRAPHY. By John Young, M.D., Professor of Natural History, Glasgow University.

London, Edinburgh, and Herriot Hill Works, Glasgow.



BUILDING CONSTRUCTION:
TIMBER, LEAD, AND IRON WORK.

E. J. Scherles 1947
Oakdale
Langley Rd
Apostle Green
R. Blackburn



Seth Whittaker
— 1878 —

Collins' Elementary Science Series.

BUILDING CONSTRUCTION;

SHOWING THE EMPLOYMENT OF
TIMBER, LEAD, AND IRON WORK,
IN THE
PRACTICAL CONSTRUCTION OF BUILDINGS.

BY
R. SCOTT BURN,

Author of "The Hand-Book of the Mechanical Arts," and Editor of
"The New Practical Guide to Masonry, Bricklaying, and Plastering," etc.

VOL. I.—TEXT.



LONDON AND GLASGOW:
WILLIAM COLLINS, SONS, & COMPANY.

1874.

[All rights reserved.]

P R E F A C E.

IN preparing the following pages, the author has been mainly desirous to place before the student a statement of the leading points connected with the employment of Timber, Lead, and Iron in the construction of buildings, in such a way that, while being to a large extent explanatory of the technical terms used in Building Construction, they would also convey a fair idea of the methods by which these various materials are used, and the forms and arrangements they assume in practice. An explanation of the natural peculiarities, and a description of the industrial characteristics and values of the materials, and of the principles upon which the structures in which they are used are based, forms no part of the scheme of the work. This is reserved for the volume on *Building Construction*, Advanced Course, in this series, to which, therefore, the student is referred.

The plan of the work is based upon the Syllabus of the Government Science and Art Department, so that it may serve as a hand-book for those who design to pass the examinations in that department to which its pages refer. But while the syllabus in its general detail has been followed, a somewhat different arrangement has been aimed at, so as to permit of a wider range of subjects being given, and their more systematic treatment secured.

The limits, no less than the scope and scheme of the work, have prevented any attempt at giving it the peculiarities of a regular treatise on *Building Construction*, which would embrace notices of various modifications in practice, or of the numerous recent inventions connected with the art. The student desirous to become acquainted with these, must consult larger works recently published, as, for example, the author's work, *The New Practical Guide to Masonry, Bricklaying, and Plastering*, to which he may be here permitted to refer.

R. S. B.

BROOK HOUSE, *September, 1873.*

CONTENTS.

	PAGE
CHAPTER I.	
DRAWING—DRAWING INSTRUMENTS—DRAWING SCALES— PLANS, ELEVATIONS, AND SECTIONS,	9
CHAPTER II.	
TIMBER CONSTRUCTION, AS EXEMPLIFIED IN THE FRAMING OF FLOORS, PARTITIONS, AND ROOFS,	27
CHAPTER III.	
TIMBER CONSTRUCTION, AS EXEMPLIFIED IN DOORS, WIN- DOWS, AND INTERNAL FITTINGS OF HOUSES,	77
CHAPTER IV.	
WORK IN LEAD AND IRON,	111

BUILDING CONSTRUCTION.

TIMBER, LEAD, AND IRON WORK.

CHAPTER I.

Drawing—Drawing Instruments—Drawing Scales—Plans,
Elevations, and Sections.

THE remarks in this chapter will be confined to simple elementary statements and descriptions. The pupil desirous to go fully into technical drawing will find the subject taken up in a separate volume, noted below.*

1. Drawing Appliances—Board and T-Square.—
The principal appliances required by the pupil in the preparation of drawings used in building construction are (1.) The drawing board; (2.) The "T" square; (3.) "Set" squares and curves; (4.) Rulers. (1.) The *drawing board* is, for common purposes, well enough made of fir or pine; but for superior boards, a mahogany, bay wood, sycamore, or plane tree wood makes a capital board. The wood, of whatever kind, should be thoroughly seasoned, as damp or unseasoned wood is sure to warp when made up into the drawing board; and the preservation of a perfectly flat surface is for this, it need scarcely be said, a *desideratum*. The shape of the board is rectangular, that is, having a greater length than breadth. It may be made of any dimensions deemed advisable;

* *Technical Drawing, for Students of Architecture and Building.*

where a wide range of drawing work is to be carried out, including detail drawings, as well as smaller plans and sections, it is useful to have several sizes of boards. For the work for beginners a useful one will be two feet long by sixteen to eighteen inches broad. The body of the board should be provided with cross pieces at each end, grooved at their edges, into which pass the tongues formed at the ends of the body or main surface of the board; the object of these cross pieces is to prevent the body from warping. In large drawing boards, the back is provided with a series of cross pieces having the same object in view.

(2.) *The "T" square*—This is so called from being composed of a thin blade or flat ruler, varying in breadth from one inch and a half up to three or four inches, according to the length of the square, and from three-sixteenths up to five-sixteenths of an inch in thickness. To one end of this the "head" or "butt" is secured at right angles, the two pieces thus assuming the form of a cross or "T," hence the name. In some forms of "T square," the blade is fastened in the centre of the head or butt, so that on each side of the blade there is a recess formed, so that when the inner edge of the head is drawn along the edge of the drawing board, the blade will slide along the surface of the board at right angles to the head. In other forms of "T" square the blade is secured to the upper side of the head, the sliding recess or rebate being thus below the blade. Another form of "T" square is that in which the head is made in two thicknesses, lying flat one upon another, and connected together by a central thumb screw. The blade of the square is secured to the upper of these two pieces, and by means of the screw the lower half of the head can be adjusted to form any desired angle with the upper half of the head. The result of this arrangement is, that by sliding the lower half of the head along the edge of the board, the blade of the square will slide along the surface at the corresponding angle to which the head was adjusted. This form of "T square" is very useful when a number of lines

parallel to one another, but not at right angles to, or parallel with the edge of the board, are required to be drawn. When this form of adjustable "T square" is used for ordinary drawing, when the head of the square is desired to be at right angles to the blade, it is necessary to see that the thumb screw is screwed tightly up to prevent the lower half of the head from separating and getting out of line with the upper half of the head. The use of the "T square" in the drawing of lines on the paper secured on the surface of the board, will be now explained. Suppose the head of the square to be sliding along the lower edge of the long side of the board (which in practice is always placed next the draughtsman, or nearest the outside edge of the table upon which the board is placed while the drawing operations are going on), the blade at right angles to it is sliding along the surface of the paper, with its edges parallel to the ends, so that all lines drawn along the edges of the blade of the square will be at right angles to the side of the board; and all these lines, at whatever distances they may be from each other, will be parallel to one another. By shifting the square so that the head will now slide along the right-hand end of the board, the blade will slide along the surface of the paper with its edges parallel to the sides of the board, so that lines drawn along the upper edge, while they will be all parallel to one another, at whatever distances they may be drawn from each other, will be at right angles to the lines drawn when the blade was in the previous position, as before explained. When long lines are required to be drawn upon the surface of the paper or on the board, at right angles to each other, this shifting of the square so that its head shall slide along the lower edge and right hand edge of the board is necessary; but when short lines are required to be drawn at right angles to any line or lines drawn along the edge of the square when in any position, they may be drawn without shifting the position of the "T square" by using (3.) *the "set square."* This is made of a thin piece of

hard wood, the edges of which are made perfectly smooth and square—that is, at right angles to the surface; the form is usually a “right-angled triangle”—that is, at which the hypotenuse is at an angle of 45° to the base. By sliding the base of this along, and keeping it in close contact—which can easily be done with a little practice—with the edge of the “T square” lying in accurate position on the board, all lines drawn along the “perpendicular” of the “set square” will be at right angles to the lines drawn along the edge of the “T square,” so that these lines can be drawn without shifting the “T square.” When this “right-angled triangle” form of “set square” is used, all lines drawn along its hypotenuse will be at an angle of 45° to those lines drawn along the edge of the “T square,” the base of the “set square” sliding as before along the edge of the “T square.” Other forms of “set squares” are used; a very commonly used one having the hypotenuse line forming an angle of 60° with the base line, this form being useful in putting down isometrical drawings (see *Drawing Book*, noted in p. 9.) “Curves” are pieces of thin hard wood, the edges of which are cut to various curved lines, the interior surface having also cut out from it portions, the edges of which also form various curved lines. These are useful for drawing curves not easily or conveniently described by the compasses, or which form part of eccentric curves not describable by compasses. Those are to be had in great variety. (4.) “Rulers” are made of two kinds—“ordinary” and “parallel.” “Ordinary rulers” made of hard wood are flat, and of various lengths and breadths, and are useful for drawing lines between points to which the “T square” is not conveniently applicable. One of the edges of the ruler is often made with a bevil, but we prefer both edges to be square to the face. The edge of a “set square” affords a good ruling surface, if long enough. “Parallel rulers,” as their name indicates, are for drawing lines parallel to one another, to which the ordinary “T square” is not applicable, or not conveniently

so. They are of two kinds—the old fashioned, consisting of two blades, connected by brass links; and the single ruler, with wheels or rollers at each end. This is the modern form of the instrument; and when the draughtsman becomes accustomed to its use, it is very much quicker in its operation than the double-bladed parallel ruler. But a beginner is apt to make mistakes in its use, hence by some the old-fashioned ruler is preferred.

2. Drawing Instruments.—A complete set of drawing instruments comprises a very considerable number of pieces,—several, however, being duplicates, so far as the principle of their construction and the mode of using them is concerned,—but of different sizes and forms;—but a very wide range of work can be done by the aid of the following:—(1.) The “large compasses,” with shifting leg, into which can be put (*a*) a leg carrying a pencil, and (*b*) a leg carrying a pen, for the drawing of pencilled and inked circles and parts of circles. (2.) The “spring compasses,” one leg of which is adjustable by means of a spring acted upon by a small set screw. By this instrument, when a measurement is taken in the compasses—as in dividing a line into any number of equal parts—if the measurement is either a trifle too long or too short, the accurate measurement may be taken by adjusting the screw. (3.) “Spring dividers”—these are small compasses for taking small measurements, the legs of which are connected by a spring and a screwed link, the latter being provided with a small set screw, so that an accurate adjustment of the divider is easily attainable; and, when once set, the measurement taken will be retained, as the screw and spring keep the legs always at the same distance. This convenience is very great when the same measurement is to be often repeated in making the drawing. (4.) The “pencil bow compasses,” for describing small circles and parts of circles in pencil. (5.) The “ink bow compasses,” for describing small circles and parts of circles in ink. (6.) The “drawing pen.” The above named instruments

will not be here further described. Without them the pupil cannot even begin to the work of drawing, he must, therefore, purchase them; and a few minutes' examination of them will convey to him a more satisfactory notion of their peculiarities and uses than pages of description here. Fuller remarks upon them will, however, be found in the work in this series, noted on page 9. To the above will be required a common (7.) foot-rule.

3. Drawing Paper and Pencils.—For the purposes of the beginner good cartridge paper will do well enough; for superior drawings the regular drawing papers should be used; they are made in sheets of different sizes, as “demy,” “royal,” “imperial,” &c., and of the different makes that of “Whatman’s”—if not the best—enjoys the highest reputation. The pencil most useful is that marked H H, although that marked H will be found, perhaps, most useful for the first lessons of beginners. The pencil should be cut so as to form a long, fine point; some prefer to finish the point round, some chisel-shaped, or flat edged. A piece of very fine sand paper is useful to finish the point, after being first pointed by means of the knife. India-rubber is used to erase pencil lines, “Indian” or “China” ink to work them in and make them permanent. This is rubbed down with a little water in colour dishes; these can be had of various sizes. For beginners, the paper may be fastened down upon the board by means of small drawing pins stuck into the corners, or by pieces of gummed paper at the same places. The method of stretching the paper by damping it and glueing it to the board by the edges will be found fully described in the volume on Architecture and Building Drawing, noted on page 9.

4. Scales used in Drawings.—The scale to which drawings are constructed are conventional arrangements by which the proportion is maintained between the measurement which the drawing gives, and the actual length of the same parts when constructed, would be. Thus, a part of any building 15 feet in length could obviously not

be drawn full size on paper; but if the length of each actual foot was supposed to be represented by a distance of an inch, a piece of paper a little over 15 inches in length would allow the line to be drawn; with a margin over, the line on the drawing paper would be 15 inches in length; but if the conventional measurement adopted was named in the drawing, it would be known that the line would be representing a line which in actual practice would be 15 feet in length. The formation of scales, of which the above is the general principle, is a matter comparatively simple, and will be found further illustrated in fig. 1, Plate I. Thus, suppose it is desired to construct a scale of “2 inches to the foot,” take in the compasses from a “foot-rule” the distance or extent of two inches, then draw any line, as $a b$, fig. 1, Plate I., and from any point c , which will be the “zero” or “0” point of the scale, set off the distance in the compasses any number of times as there are to be feet in the scale, from c towards b , on the line $a b$, to d and e . The size of the Plate here limits the number of times the distance $c d$ and b twice to three. Then each of the distances will represent a “foot.” But as there are inches in the foot to be arranged for in the scale, divisions must be made to represent these inches; the large division to the left hand, as from the zero point, c to d , is that usually allotted to the inch division, this being divided, in large scales, into twelve equal parts, each representing an inch; but if the scale be small, as in fig. 10, then these first divisions, as $a b$, fig. 3, Plate I., is only divided into four parts, as $a f$, $f e$, $d e$, $e b$, each of these representing three inches, the extent or length of an inch in these small scales being guessed at. This is exemplified in the scale in fig. 10, which is a scale of “ $\frac{1}{4}$ inch to the foot,” or of “4 feet to the inch.” Fig. 8 is a scale of “2 feet to the inch,” or, as more commonly expressed, a scale of “ $\frac{1}{2}$ inch to the foot.” Fig. 9 is a scale of “3 feet to the inch.” Fig. 11 is a scale for a detail drawing, “one-fourth full size” or $\frac{1}{4}$ of

a foot, or "3 inches to the foot." Fig. 14 is a scale of $\frac{2}{3}$ of a foot; or two-thirds of full size. Fig. 15, a scale of $\frac{5}{8}$ of a foot or of full size, both with "eighths" marked. Fig. 4 shows the scale of 2 inches to the foot completed, with the division in the first division to the left indicating inches, all the larger divisions being feet. Fig. 2 represents a scale of "1 yard to the 2 inches," the last division, $a b$, being divided into three, as $a d$, $d e$, and $e b$, each division representing a foot, the other divisions, as $b f$, representing a yard. Fig. 7 represents a scale of 10 feet to $\frac{3}{4}$ of an inch, used like the last, in laying down drawings of general plans, where the distances and measurements are great. In this scale of tenths, the last division is divided into ten equal parts, each representing a foot, and each of the larger divisions represent ten feet. Fig. 12 is a scale of "5 feet to the inch;" and fig. 13, "10 feet to the inch," with "inches" marked. Fig. 5 is a scale of "1 $\frac{1}{2}$ inches to the foot;" fig. 6, a scale of "1 inch to the foot."

5. Practical Use of the Scales in Drawing Plans, &c.

—*To take measurements from scales* is a simple matter. Suppose the drawing, of which the dimensions of various parts are required to be taken, is drawn to a scale of "1 inch to the foot;" and suppose that a certain distance from point to point of any given line in the drawing is taken in the compasses, then, by applying it to the scale, as say that in fig. 6, which is a scale of 1 inch to the foot, while one leg of the compasses is in the point 4, while the other reaches to the point 6 in the last division of inches, then the measurement of the distance in the compasses, and by consequence that of the part represented in the drawing, is shown to be 4 feet 6 inches. Again, suppose that to a general plan a scale of "10 feet to three quarters of an inch" is attached, and the actual length of a line taken in the compasses from the drawing be required to be known; if by applying the compasses to the scale, as in fig. 7, Plate I., the one leg of which being at the division marked 50, and the other reaches to the point 5

on the division to the left; then the distance is known to be 55 feet.

To lay down measurements from a scale is the exact converse of the above, and is simply done. Thus, suppose that on the line $a e$, fig. 1, Plate II., it is desired to lay down a line, as $a b$, representing the side of a box, as $a b c d$, and that the drawing is to be made to a "scale of $\frac{1}{4}$ of an inch to the foot." First, draw the line $a e$ along the edge of the square, in a light pencil line; if the length of the side of the box, as $a b$, is to be 8 feet 9 inches, then on the scale, as in fig. 10, Plate I., put the point of one leg of the compasses in the division to the right, marked 8, and draw out the compasses till the point of the other leg reaches exactly to the point indicating the ninth division on the division of inches to the extreme left of the scale; then take this distance, and with one point of the compasses, on the line $a e$, at a , measure from a to b , this will give a line in length equal to 8 feet 9 inches, as desired. The depth of the box, as $a c$, which we shall suppose to be 1 foot 2 inches, is measured from the scale in fig. 10, Plate I., in the same way, and the mode of drawing it is as follows:—Suppose that the edge of the square is coincident with the line $a b$, previously drawn; move the square so that the edge be a little below the line, as $f g$ in fig. 1, Plate II.; then take the "set square," as represented by the dotted lines at h , and, putting the base on the edge of the square, as $g f$, slide the set square till the perpendicular of the base be coincident with the point b , on the line $a e$, and draw a line along the edge $b d$; then slide the "set square" along the edge of the "T-square," till its perpendicular be coincident with the point a , in the line $a e$; next, from the scale in fig. 10, Plate I., take the distance in the compasses of 1 foot 2 inches, by measuring from the first large division marked 1 to the second small division in the part o , 12; and, with this distance in the compasses, set one leg in the point c , and with the other mark a point in the line $a c$, at c ; next, move the "T-

square" up the board till its upper edge be coincident with the point *c*, and draw a line along the edge cutting the line *b d* in the point *d*; the outline of *a b c d* will then be drawn, and the lines *a b*, *c d* will be parallel to each other, as will also *a c*, *b d*. Dimensions, when marked on drawings, are usually put in as shown in fig. 1, Plate II., between marks as $\langle \text{---} \rangle$, with a dotted line; the acute angles of the marks being the limits of the line of which the dimensions are figured.* In some drawings, owing to the complications of the parts, or to preserve the drawing itself from being marked with figures, the dimensions are indicated in the manner shown in fig. 1, Plate II.; the lines, as *c a*, *d b*, being extended in dotted lines to a short distance beyond the drawing, and the dotted line put between the marks $\langle \text{---} \rangle$ as shown. The other measurement in this diagram is indicated in like manner at *k e*. In finished drawings these dimension marks, $\langle \text{---} \rangle$, should be put in neatly and carefully. This will best be done by the aid of the "set square," as shown in fig. 2, Plate II. Thus, let *a b* be the dotted line terminated by the dimension marks at *a* and *b*; let *c d* represent the upper edge line of the "T-square," and the dotted triangle, *d e f*, the "set square," the base, *e d*, of which is placed on the edge, *c d*, of the "T-square;" adjust the "set square" so that its hypotenuse, *e f*, is coincident with the point *b*; then along the edge draw a short line, marked in the diagram by a strong black line; the corresponding angular line is drawn in at *a*, by sliding the set square along the edge of the "T-square," till the point in the hypotenuse is coincident with the point *a*. The reverse angular line is put in by reversing the position of the "set square," as shown by the dotted lines, *g c h*; the angular lines should all both be of the same length. In

* The figures, as " $\frac{1}{4}$," put to the foot of the diagrams to follow in this volume, are meant to denote the scale to which the drawings are made. Thus, in fig. 1, " $\frac{1}{4}$ " means that the scale of the drawing is " $\frac{1}{4}$, or one-fourth of an inch to the foot."

place of putting to drawings the scale in the manner as indicated in fig. 10, Plate I., it is the practice of some architects and builders to write merely on the drawing the scale to which it is made, as "scale, 1 inch to the foot," "scale, $\frac{1}{2}$ inch to the foot," and so on. Some make the matter more simply still, by merely writing " $\frac{1}{8}$ th scale," or "one-eighth scale;" or " $\frac{1}{12}$ th scale," or "one-twelfth scale." This does not mean that the $\frac{1}{8}$ th scale, for example, is " $\frac{1}{8}$ th of an inch to the foot," but that it is $\frac{1}{8}$ th of a foot, or "equal to a scale of $1\frac{1}{2}$ to the foot." A $\frac{1}{12}$ th scale is thus equal to 1 inch, as there are 12 inches to the foot, and is equal, therefore, to a scale of "1 inch to the foot;" a $\frac{1}{4}$ th scale is equal to "half an inch to the foot;" a $\frac{1}{6}$ th scale equal to "2 inches to the foot." But in all cases it is by far the most satisfactory method to draw a properly divided scale to each drawing. The easier methods above-named go on the assumption that in the office, scales (on ivory or box-wood) of various sizes are at hand, from which the specific dimensions of certain parts can be taken; but drawings are often referred to in the actual carrying out of the work, in circumstances where these scales are not available, so that it is better to put a properly divided scale to each drawing as recommended. At all events, this should be done in the drawings of pupils beginning practice. Scales of tenths, as in figs. 7 and 13, Plate I., are, as already stated, used for laying down drawings of general plans, as block plans, where the measurements are long. As a useful lesson in drawing, and as further exemplifying the use of scales, we shall suppose fig. 3, Plate II., to represent the plan of the ground upon which a house is to be erected. The scale to which this is drawn being that in fig. 7, Plate I., which gives 10 feet to three-quarters of an inch, the first thing to be done is to draw a line representing *a b* in fig. 3, Plate II., along the upper edge of the "T-square," the blade of which is parallel to the lower edge of the drawing board—the butt or head of the "T-square" being thus placed on the edge of the right hand end of the drawing board. The length

of the line ab is marked in the drawing as shown to be equal to 35 feet. This is taken from the scale in fig. 7, Plate I., by putting one point of the compasses in the division marked "30," and extending the other to the point "5," in the division to the extreme left of the scale. Then, from any point on the line ab , fig. 3, Plate II., as a —this point being selected so as to put the drawing when finished as nearly in the centre of the paper as possible—mark off the distance taken from the scale to the point, as b , fig. 3, Plate II.; the length of the line ab will then be equal to 35 feet, measured from the scale, fig. 7, Plate I. The next point is to obtain the position of the point c in the drawing, fig. 3, Plate II. On the drawing which is being thus copied extend by a very fine and light pencil line—so that it can be easily erased—the line dc to some distance beyond the point c , as, say, to the point e . Next, at right angles to the base line ab , draw another line, lightly put in by a pencil line, so as to cut the line dc extended in e . On the paper on the drawing board draw now a line from a (or, rather, from the points on the drawing board corresponding to the point a in the copy, which is supposed to be fig. 3, Plate II.), perpendicular to ab ; this can be done by shifting the "T-square" so that the blade will be run parallel to the end of the board, the head or butt running along the lower edge of the drawing board; or, if the line is not too long, the "set square" can be used, as described in connection with fig. 1. Take from the copy the distance ae , and measure it on the scale, fig. 7, Plate I., and set off, from a on the drawing board, this distance, cutting the line ae in the part e . Through e draw along the edge of the square—which is again shifted, so that its blade shall be in its original position, that is, parallel to the lower edge of the drawing board—a line ef ; this line will correspond to the same line in the copy, fig. 3, Plate II., and will be the same distance from the line ab . Take in the compasses the distance ec from the copy, and measure it from the scale, fig. 7, Plate I., and from the corresponding

point e on the drawing board, set off this distance from ae to c ; the position of the point c will thus be obtained, and, if the operations have been correctly performed, the length of the line ac , when measured from the scale, fig. 7, Plate I., will be found to be as marked—33 feet 6 inches. In practice, where the copy is to be the same size as the original, the length of the lines ae and ec need not be measured from the scale, but simply transferred from the copy to the drawing board, as above described. The next operation is to measure from the scale the distance cd 22 feet, and transfer it to the drawing board, or, rather, the paper on its surface. On examination of the copy, the line dg will be found to be exactly at right angles to the line cd . The "set square" should then be brought into use, and by it the line dg should be drawn of same length, and on it the distance taken from the scale—namely, 13 feet, set off from d to g . The line gh will be found, on examining the copy, to be parallel to ab ; draw, then, on the paper the line gh at right angles to dg , or parallel to ab , and make it equal to 7 feet; join hb , and the plan is complete. The line bh is not at right angles to the line ab ; and the accuracy of the drawing will be tested by measuring this; and if the drawing be correct, it will be found to be 20 feet. But in place of the copy being accurately drawn—as it is supposed to be, in fig. 3, Plate II.—the case may be supposed that the copy might be a rough outline sketch, something like the form of fig. 3, with the dimensions or measurement marked on it; in this case, if the pupil was desired to make an accurate drawing to scale of this rough sketch, no such facilities for ascertaining the position of the point c in relation to the point ba would be afforded such as we have described. The pupil would therefore have a very different process to go through before he could make his drawing. We have also stated that by examination of the copy he could ascertain whether the line dg was or was not at right angles to cd . This could only be done if the copy was accurately drawn, and very simply by placing the copy on the drawing board, and

marking the base line parallel to the edge of it, by means of the "T-square," and then shifting the square to test the line $d g$. Examination like this can, after a little practice, be very quickly made. But, if a rough sketch was provided, the line $d g$ might be put in obliquely, as also the line $g h$. The pupil will find in the volume noted on page 9 full instructions how to draw from rough sketches, or from the ideas of his own mind, which, in the case of original work, take the place of rough sketches. For the method of constructing and of using "diagonal scales," see the volume in this series noted on page 9.

6. Scales for Detail or Enlarged Drawings.—These are constructed on the principle already explained for scales for general plans, but are designed to give facilities for measuring fractions of the inch, just as the division to the extreme left of scales, such as in fig. 6, Plate I., give fractions of the foot. And, as there are eight equal parts in an inch, which are technically called "eighths of an inch," the last division of the scale to the left is divided into eight equal parts, each of which is equal to $\frac{1}{8}$ th of an inch as read off from the scale. A scale constructed on this principle is shown in fig 14, Plate I., which is a scale of 3 inches to the foot. The measurements are taken from this in the same way as already described, so far as feet and inches are concerned; but if, in the measurement, parts of an inch be given, the compasses are extended to the point indicating the measurement in the last division of the scale to the extreme left. Fig. 15 is a scale of $\frac{5}{8}$ ths of a foot, or $\frac{5}{8}$ ths of full size. Detail drawings in practice, as a rule, are drawn to scales, some regular proportion of a foot, as $\frac{1}{4}$ th of a foot, or "3 inches to the foot," $\frac{1}{6}$ th or "2 inches to the foot," and sometimes half size, which is equal to "6 inches to the foot." The scales being named in the order above given, as "one-fourth full size," "one-sixth full size," "one half size." When details are made, say half size, no regular scale is required to be constructed; as all the measurements can be taken from the

ordinary foot rule, for all that is necessary is to take half of the full size measurements which the object would present: thus, if a distance was 6 inches, 3 inches would be taken; if 4 inches, 2 inches, and so on. Again, if the detail would be drawn to "one-fourth full size," one-fourth of the full size measurements would be taken: thus, if the measurement was 8 inches, 2 inches would be laid down on the drawing; if 6 inches, $1\frac{1}{2}$ inches would be taken from the ordinary foot rule, and so on. In these, the eighths of an inch, if any, in the measurement, would be approximately taken or allowed for: thus, $\frac{3}{4}$ ths of an inch, or "six eighths" in a detail drawing "half full size" would be represented by a measurement of three eighths; an eighth by half this or " $\frac{1}{16}$ th" of an inch, and so on.

7. Plans, Elevations, and Sections.—The various structures, and parts of structures, met with in building construction; are solids, having length, breadth, and thickness, and sides more or less numerous, according to their form. The paper on which the drawings connected with building construction are made, having only surface, that is, length and breadth, some method of representing upon a flat surface, the form of solids, so as to show each side and the peculiarities in construction dependent on, or connected with, that side is obviously required. The delineation upon paper of an object which is a solid is, technically speaking, a "projection;" and the peculiar method of projection employed in building construction is called "orthographic projection." For the principles of this, and other kinds of projection, as "isometrical," the pupil is referred to the volume in this series on *Plane and Solid Geometry*. The projection of any body taken on a line parallel to its base, or as viewed when looking down upon it in the direction of a line at right angles to its surface, is called a "plan," as fig. 4, Plate II., which may be supposed to represent the plan of a house, or of a box with the lid or top taken off. Plans of houses are, in reality, "horizontal sections," taken on a line, at a distance a little above the ground level, which line is parallel to the

base. A "section" is the view of an object, representing it as it is supposed to appear, when it is cut either horizontally or vertically by a line parallel to any given line in the plan. Thus, fig. 4, Plate II., may be taken as a "horizontal section," on the line $a b$, in fig. 5, Plate II., showing the thickness of the walls of the house, or of the thickness of the sides of the box, as the case may be. The section in fig. 6, Plate II., is called a "longitudinal section," or a "longitudinal vertical section," on the line $a b$, in the plan fig. 4, Plate II., this line being parallel to the front and back lines. If the section was taken on the line $c d$, fig. 4, Plate II., the section would be called a "transverse or cross section," or a "transverse vertical section." "Elevations" are views of the vertical or standing part of objects, and are called "front elevations," "back elevations," "end elevations," or "side elevations," according to the side from which the object is viewed; the point of view being taken from a point at right angles to the surface of the front, back, end, or side of the object. Thus, fig. 5, Plate II., is a front elevation, and gives the height of the openings e, f , and g , in plan fig. 4, Plate II., the breadth of which only is there given; fig. 7, Plate II., is the "end elevation," A, fig. 4; fig. 8, Plate II., the "end elevation," B, fig. 4, Plate II. If the object were a house, these two end elevations would be distinguished by the points of the compass to which they looked, as "west-end elevation," "east-end elevation." The "back elevations" of fig. 4, Plate I., will be the same as fig. 5, omitting the openings e and f , with the opening g , the same as in fig. 5, Plate II. Where there are peculiarities in the back part different from the front part of any object, a back elevation would be necessary. The pupil desirous further to pursue the subject of drawings is referred to the volume noted in p. 9. But we give a few examples of a simple kind to show methods of copying and laying down drawings. In fig. 9, Plate II., we give a drawing showing a "front elevation" of a building, of which, in

fig. 10, we give part "ground plan." The two drawings are placed in relation to each other to show the method of taking the lines of an elevation from the distance given in the ground plan, and *vice versa*. A glance at the two figures 9 and 10, in Plate II., will show this; the dotted lines being carried up from the plan to give the lines of front elevation, or carried down from the elevation to give the lines of the plan. The letters of the two diagrams, figs. 9 and 10, show corresponding parts; and the pupil, by a study of these should be able to understand, to see the principle of the method adopted, and be able to apply it to other subjects of a like nature. In Plate III., fig. 1, we give a diagram showing the method of "laying down" or "setting out," the principal lines of the elevation of building in fig. 9, Plate II. The line $a b$, fig. 1, plate III., is first drawn as the "ground line" or "base line." Near the centre of this line, as at the point c , a line $c d$ is drawn at right angles to $a b$. This is the main "centre line" of the building, and corresponds to the line $k l$, in fig. 9, Plate II. From c the distances, $c e, e g$ (equal to the distance of centre lines $m n, o p$, fig. 9, Plate II.) are set off; and lines $e f, g h$, are drawn parallel to $c d$; these give the centres of the side wings, $a b, c d$, fig. 9, Plate II. The heights of the points r, s, t (taken from the copy the drawing in fig. 1, Plate III., being to a larger scale than that in fig. 9, plate II.), are then to be set off from the base line $a b$, fig. 1, Plate III., to the points f, h, d , and b , and lightly pencilled lines drawn through these parallel to the base line $a b$. The distance of the terminating lines of these lines on each side of the centre line, $p o, k l, m n$, fig. 9, Plate II., should then be taken and set off from points $f h$ and d , on both sides of the centre lines $e f, c d$, and $g h$, this will give the width of the respective parts. The heights of the top and bottom lines of windows, as i and e , fig. 9, plate III., should then be taken and set off in the lines, $e f, g h$, fig. 1, Plate III., to the points, $m n, o p$, and through these points lines drawn parallel to $a b$, the full lines show the parts when inked in, the dotted lines

represent the lightly pencilled in lines at the first operation. Fig. 2, Plate I., is an enlarged sketch of the window *e*, in fig. 9, Plate II., showing the method of drawing it. First, draw a "centre line," *a b*, and a "base line," *c d*, at right angles to this; then set off the various heights, as *b*, *e*, and *f*, those taken from the copy, or the scale according to dimensions given. Then take half the width of opening and set this distance off, on each side of the centre line, *a b*, to the points, *g* and *h*; then draw parallel to *a b* lines, *g k*, *h i*, making the line drawn through *f* parallel to *c d*. Measure next to the end *s c d*, and draw *l c*, *m n* parallel to *a b*. Fig. 3 shows the lines required to draw the door in fig. 6, Plate II., fig. 4 being an enlarged sketch, showing the method of putting in the panels; in this *a b* is the "centre line" of the door, corresponding to *a b* in fig. 3, and the line *c d*, fig. 4, Plate III., gives the top line of panels, the widths of the panels being set off from the point *a*, to *e* and *f*. Fig. 5 shows the method of drawing a pediment terminating a roof. The line *a b* gives the upper line of last number of the cornice, and *c e* the centre line of roof; from *b*, set off the height *b c*, measure from *a* to *d*, and join *c d*. Fig. 6, Plate II., is a front elevation of a house, the leading lines of which are given in fig. 7, showing the method of commencing the drawing; fig. 8, Plate III., is pediment of door; fig. 9, drawing, enlarged, of chimney stalk, and fig. 10 shows the method of drawing in the "quoins;" the distance, *a b*, being divided into nine equal parts, and lines drawn through them parallel to *c d*; the line *a b* is the outside boundary line, and the projections of the quoin stones inward from this are given by measuring from the point *e*, to *f* and *g*; and drawing from these, lightly pencilled in lines, the intersection of which, with the lines drawn through the points 1, 2, 3, &c., parallel to *c d*, give the widths or breadths of the quoins.

CHAPTER II.

TIMBER CONSTRUCTION AS EXEMPLIFIED IN THE FRAMING OF FLOORS, PARTITIONS, AND ROOFS.

THE operations to be described under this head are those with which the carpenter is concerned, the framing of the various constructions being made up of members of considerable size and weight, and known under the general term, or name, of carpentry; this being distinguished from the operations of joinery, which concerns itself with the fitting together of pieces of timber of small size and of comparatively little weight. Carpenter's or framed work may be divided into several sections, as floors, partitions, and roofs, and of general work, as centring of bridges, timber bridge work, gates, etc., etc. It is with the first three of these only that this treatise concerns itself, and we shall take them up in the order here named.

1. Floors.—In constructing floors, the assemblage of timber is made up according to one of three modes: first, "single flooring;" second, "framed floors, or double floors;" third, "double framed floors;" these are illustrated in elevation, plan, and section in Plate IV., and are described in the following paragraphs:—

(a) *Single Floors.*—This species of floor consists of a series of timbers termed "joists," or "flooring joists," (*a a*, fig. 1, Plate IV.), the ends of which rest on the walls *b b*, and run in a direction at right angles to these. In common, and, we may here say, in bad work, the joists on the lowest, or ground floor, at their ends simply rest upon, and are built into, the wall material, as brick or stone. In better class work the ends of the joists rest upon, and are framed into, or secured to, "wall plates," as *c c*, fig. 1, Plate I., these being set into and rest upon the walls, as shown in the best work. The "wall plates" and ground floors rest upon, and are supported by, small piers or pillars

of brick or stone, these being carried up from the ground to the level of the under side of flooring joists. The object of these piers is to preserve the soundness of the timber, by leaving it exposed on all sides; timber being found to decay much more rapidly when built into walls and surrounded by brick, or stone and mortar, than when left freely exposed to the air. In the upper floors of buildings the joists are built into the walls, as in fig. 1, Plate IV. At right angles to the "flooring joist" *a a*, the "flooring boards" *d d* are placed, and, of course, on the upper side of the joists. These boards are laid and secured to the joists in one of several ways hereafter in present chapter to be described. Such is a "single floor" as employed on the ground floor of a building; but, in the upper floors, where a ceiling is to be carried by the floor timber, "ceiling joists," as *c c*, fig. 2, Plate IV., are secured to the lower edges of the joists, running in a direct line at right angles, to these. To these "ceiling joists" the laths which support and carry the plaster are secured. The "bearing," or "span," or distance between the walls in which the joists, *a a* fig. 1, rests, should not exceed twenty-four feet for single floors on the ground level, but as this is, however, too great, we are disposed to place the maximum span at twenty feet. The "span," or "bearing," as it is more frequently termed, is measured from inside the walls, as shown by the dotted lines in fig. 1, Plate IV. The illustration being of a floor for a fifteen feet bearing, half only up to the centre line *e f* being given. Where a ceiling is to be carried by the floor, as in upper floors, the span should not exceed fifteen feet. The "bearing" of the joists on the wall plates should not be any less than four inches, but, according to the bearing of the joists, may go from this up to nine inches. By the term "bearing," here given, is meant the part, or length, of one of the joists which rest upon the wall or wall plate, as the part *g h* in fig. 1, Plate IV. The distance between the joists is usually fourteen inches, this distance being measured from centre to centre of the joists, as shown in fig. 3. Where the

bearing of the joists is considerable, and the depth, therefore, increased, they should be strengthened, and lateral movement prevented by what is called "strutting." The simplest form of strut is a flat and thin piece of board, as *i i*, fig. 2, placed between the joists, the strut bearing at its ends in the faces of the two contiguous joists. The struts are all placed in line, as at *i i*, fig. 2, Plate IV. A more complicated and complete form of strutting is known as "herring bone strutting," and is illustrated in fig. 11, and is formed by two pieces crossing each other, butting at each end on the faces, or inner sides, of the joists, and secured thereto by nails. In superior work the struts are slightly notched at the bearings into the joists. In fig. 2, Plate IV., the plan of the herring bone strutting is shown at *j*. As simple longitudinal struts, as *i i*, in fig. 2, are sometimes apt to give way laterally, the best plan is to make the edges butt up on one side to triangular fillets nailed to the joists, as shown in fig. 14, Plate IV., where *a a* is part of the face of joist, *b b* the strut, *c* the triangular fillet. For joists with a "bearing" of from eight to ten feet, one row of strutting, as *e e*, fig. 2, Plate IV., will be sufficient, allowing another row for each four feet of increase in length of bearing of the joists. Fig. 2 is a plan, and fig. 3 a cross section, of which fig. 1 is the side elevation. In all, corresponding letters are used to indicate corresponding parts.

(*b*) *Framed and Double Floors.*—In this kind of floor there is a member in addition to those forming the assemblage of timbers in a single floor. This additional member is called a "binder," or "binding joist," as *b*, in fig. 4, Plate IV., *a a* being the "flooring joists," corresponding to *a a* in fig. 1, *c* the "ceiling joists," and *d d* the "flooring boards;" *e e* indicates the line of plaster on ceiling. Fig. 5 is a side elevation of this double floor, fig. 6 a cross section, *a a* being the flooring joists, also sometimes called "bridging joists," *b b* the "binder," or "binding joists," *c c* the "ceiling joists," *e e* line of lath and plaster ceiling. Fig. 8 is part plan. The thickness

of the binding joists varies with the bearing; as a rule, they are made half as thick again as the flooring joists of the corresponding floor, the bearing on the wall, *g h*, fig. 1, Plate IV., will be ample if at six inches. The distance between the binders, measured from centre to centre (see figs. 4, 5) is generally from five to six feet. When, in the arrangement of the timbers of a "double floor," the binding joists are placed to, or come near a wall, their thickness is reduced one-third; thus, if the binder is nine inches thick in the central part of the floor, it is only six inches when near a wall. When a fireplace interrupts the line of joisting, or when a hole is required to be made in a floor to receive a staircase, or a trap-door, etc., etc., an arrangement known as a "trimmer," or "trimming joists," is introduced—this is illustrated in fig. 9, Plate IV. In this drawing, *a b* represent the jambs of a fireplace projecting from the wall *c c*, *d d* show two of the ordinary "flooring joists," *a a*, figs. 1, 2, Plate I., the other joists, as *e e*, are broken off, and in place of resting upon the wall, which cannot be used as a bearing surface for them in consequence of the fire-place, they are jointed to, and are carried by, the cross joist, which is termed a "trimmer," *f f*, this being at its ends jointed to, and carried by the "trimmer," or "trimming joists," *g g*, which run parallel to the flooring joists *d d*, *e e*. The "trimmers" *f f*, and "trimming joists" *g g*, are thicker than the flooring joists *d d*, *e e*, one-sixth or one-eighth of the thickness of the flooring joists being added for each joist, *e e*, carried or supported by the "trimmer" *f f*.

(c) "Double Framed Floors."—Floors of this sort, in addition to "flooring joists," "binding joists," and "ceiling joists," have an additional member, this being called a "girder," or sometimes simply a "bearer." Floors of this kind are used with large bearings, or where heavy weights have to be supported. The ends of the "girder" are carried by the walls, and are, or should be, placed in the parts where there is no opening, as that of

a window or door, below; that is, on the part of the wall which is solid from bearing of girder to the ground or footing. And in order to allow of the pressure on the wall being distributed as much as possible, the girder *aaa*, fig. 10, Plate IV., rests upon a "plate," or "or template," *b b*, which will be better if of stone than of wood. This plate should have a considerable projection on each side of the bearer; a stone cap *c c*, and backpiece *d*, are usually added, thus enclosing the end of the girder *a a* in an open box, so to call it, thus freely exposing the timber to the air. Girders are sometimes placed in cast iron boxes, called "girder boxes;" examples of these will be found in the second, or "Advanced Course of Building Construction" in this department of the present series of works. In place of inserting the ends of "girders" into apertures in the walls, as illustrated, or into cast-iron boxes, they are sometimes made to rest at, or bear upon, the upper surfaces of stone corbels, which project from the wall, thus keeping them free from it, and quite exposed to the air. The girder *a a*, fig. 10, Plate IV., carries the "binding joists," *e e*, which are framed, or jointed, to the sides of the girders, as shown in fig. 11, Plate IV., and the "binding joists," *ee*, carry the "flooring, or bridging joists," *ff*, upon which the "flooring boards," *g g*, are placed. The "ceiling joists," *h h*, are carried by the binders, and to these are secured the laths and plaster ceiling, *i i*. The distance apart of the "girders," *a a*, fig. 10, Plate IV., is usually ten feet from centre to centre, the bearing on the wall nine to twelve inches. In Plate IV., fig. 11 is a cross section, and fig. 12 part plan of the double framed floor, of which fig. 10 is side elevation. The corresponding parts are indicated by corresponding letters. All the drawings in Plate IV. are drawn to a scale of "half-inch to the foot." The "herring bone strutting" is shown at *j j* in fig. 11. Floors are, in the better class of floors, provided with what is called "deadening" or "deafening." This is made as follows:—To the sides of the flooring joists, *ff*, fig. 11, small "fillets," or "firing

pieces," *k k*, are nailed, these carry the "sounding boards," *l l*, on which is laid the "pugging" *m*, composed of a coarse plaster, and sometimes cut hay or straw, or of coarse plaster and mortar alone. Fillets are sometimes nailed to the lower edges of the joists to carry the laths; these fillets serve, in the case of thick joists, as keys to the plaster, in addition to those afforded by the laths. The operation is termed "firing down."

2. Flooring Boards.—The boards which form the walking surface of a floor are laid upon the joisting in one of three ways. First, "folding floors," "straight joint floors," and "dowelled floors." In the first of these systems, the boards are laid four or five close together, the fourth and fifth boards being laid rather closer, or nearer, to each other than would be due to the space which they would occupy if laid so as to allow the intervening boards to go easily into the space left between this board and the one laid last down. The result of this is, that the space left for the three or four boards to go into, is rather less than the space they would actually occupy; these four boards have therefore to be forced or jammed into the space, this being done generally by laying down a flat board, and pressing this down with the foot. Thus, suppose the board, *a a* in fig. 1,* to be the last laid down, the fourth board, *b b*, is then nailed to the rafters, so as to make the space between it and *a a* a little less than the space required by the three intervening boards, *c d* and *e*, these being forced into the space between *a a* and *b b*, and when flat, secured by nails to the joists *f f f f*. The "heading joints," *g g*, that is, the lines where the ends of the contiguous boards butt against each other, are not in this kind of flooring specially attended to, three or four meeting in the same line, as at *g g*. The "heading joints" should be arranged so as to meet in the centre, or, at least, above

* Where figures as " $1\frac{1}{2}$," in fig. 4, are placed at the under part of a diagram, they denote the scale to which the drawing in the figure is drawn, thus, fig. 4 is drawn to a scale of " $1\frac{1}{2}$ inches to the foot," or " $1\frac{1}{2}$."

the edges or solid face of rafters. In "straight joint floors,"

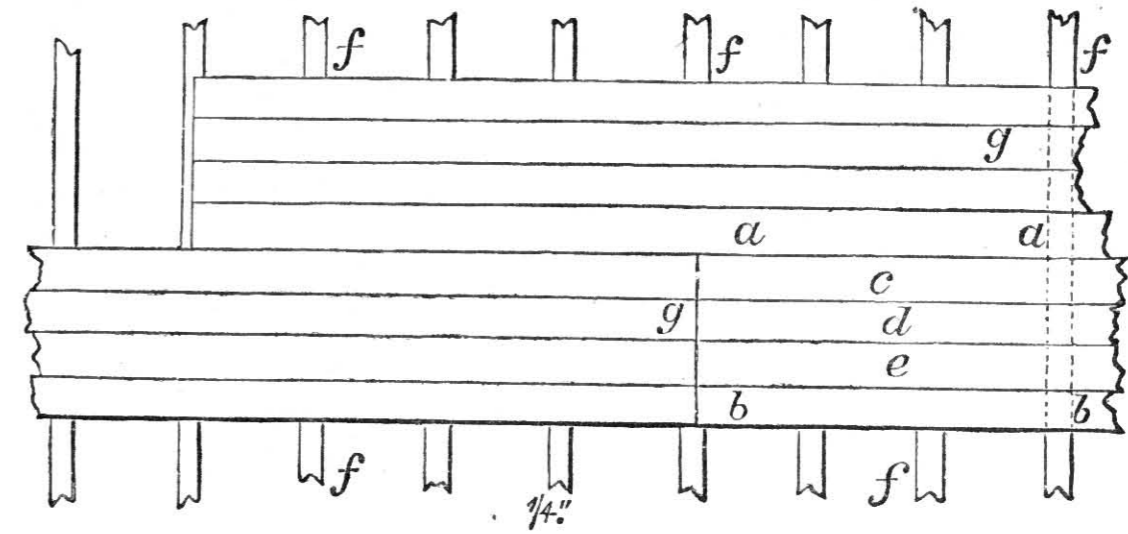

Fig. 1.

the boards are laid across the joists, *a a a a*, fig. 2, with the vertical, or side joints, in one continuous line, one board being laid down and secured to the joists at a time, and

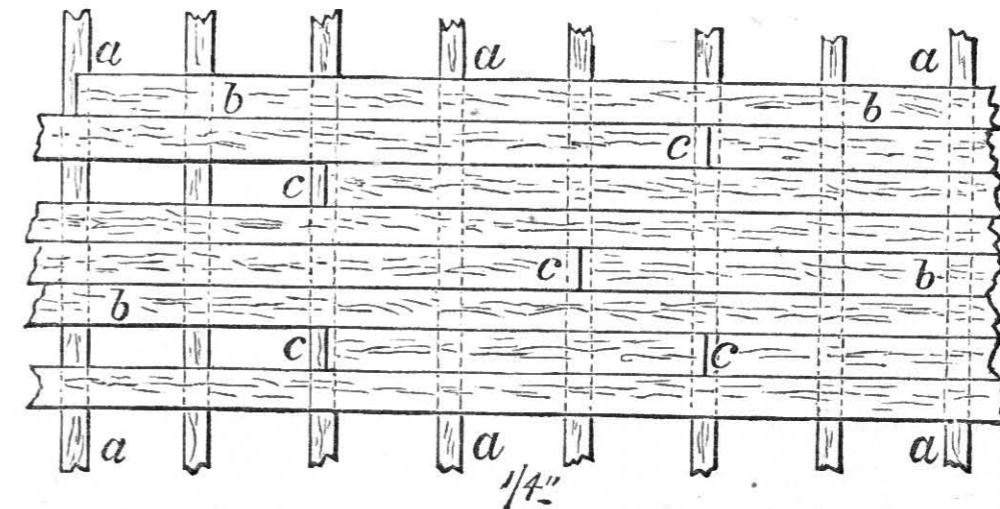

Fig. 2.

the next forced up close in contact with it, so as to make the joint good, this being done with an instrument known as a flooring clamp. The edges of the boards, as *b b*, are kept in close contact by one or other of the methods presently to be described. The "heading joints," *c c*, are generally secured together by one or other of these joints, or, simply, in the least expensive work, made to butt against each other. In "dowelled" floors, the boards are laid straight, joints edge to edge, but are kept together by

dowels, or pieces of oak or beach set into the edges of the boards, as shown in fig. 3, in which *a a* are the joists, *b b*

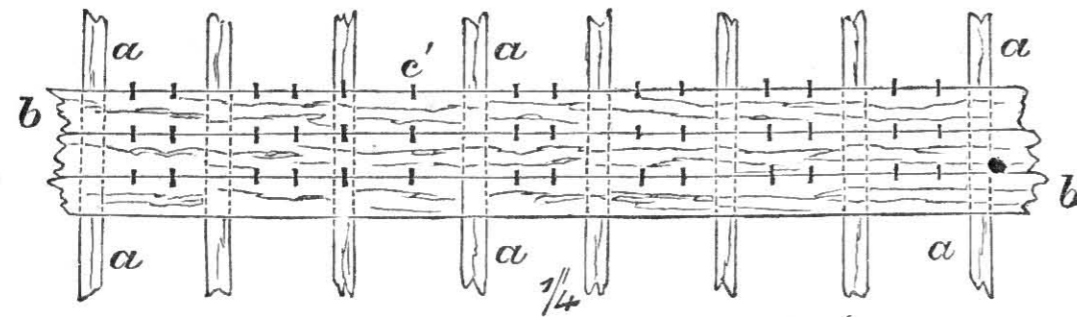

Fig. 3.

the flooring boards, *c c* the dowels. In fig. 4 the position of these is shown to a larger scale, $1\frac{1}{2}$ inches to the foot, the length of the dowels, *a a*, being about $3\frac{1}{2}$ inches, and

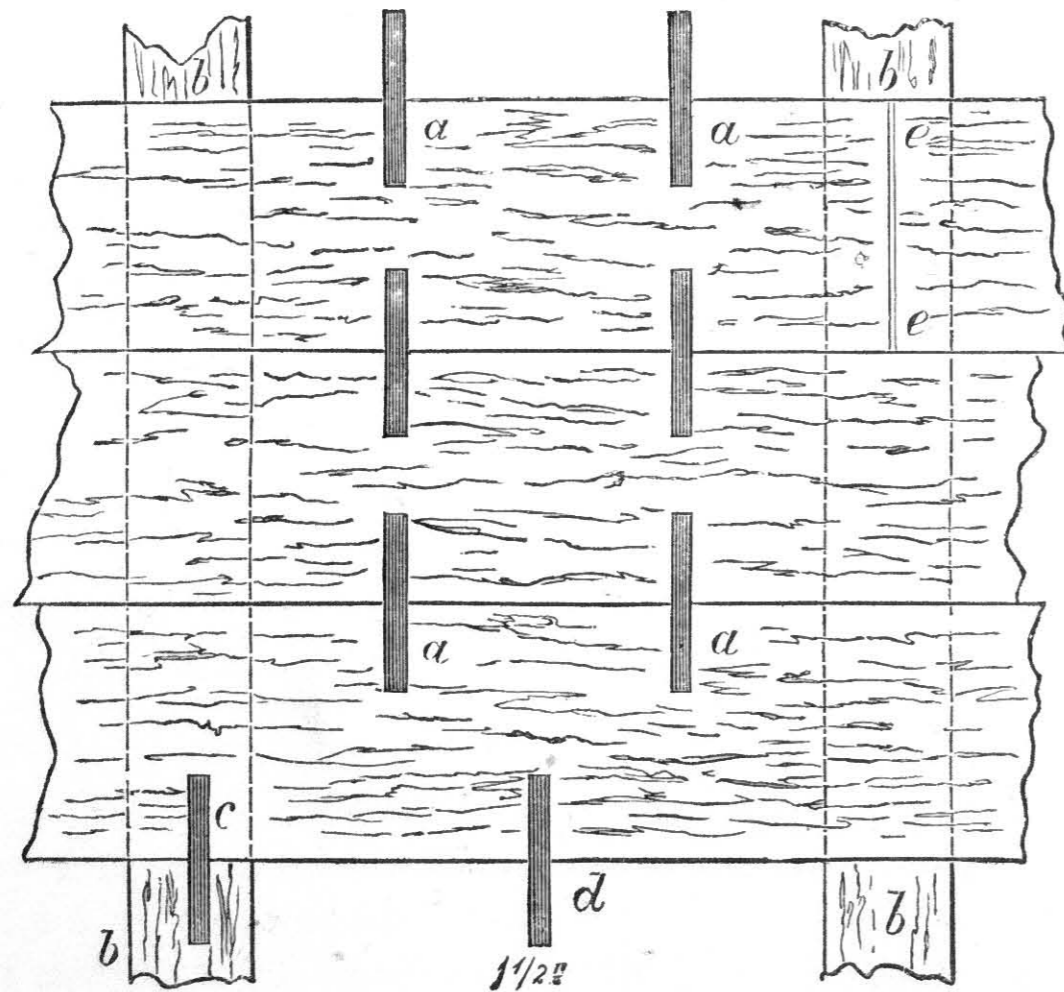

Fig. 4.

the diameter $\frac{5}{16}$ ths. The dowels may be inserted as shown at *a a a a*, two dowels being given to the space between the two joints, *b b, b b*; or the dowel may be placed so that it

will be above the joists, as at *c*, the other as *d*, in the centre of the space between the two joists *b b*. The flooring boards, in "straight joint," *d'*, and "dowelled floors," are joined at their edges, by joints running in the direction of the length of the boards, by one or other of the methods illustrated in figs. 5 and 6, by a "rebated" joint, as at *b b* in figs. 5 and 6, "tongued" and "grooved," as at *c* in same figures. In "folded floors" (see fig. 1) the edges of the boards are straight-jointed, as at *a* in fig. 5. In this form the boards are nailed to the joists at both edges; but in dowelled boards, or "tongued" or "rebated" joints, as *b* and *c* in fig. 6, one edge only may be nailed, the tongue or groove keeping the other boards down. In the better class of work, the boards are nailed at the outer edge only, the nails or brads being driven in a slanting or oblique direction. The mode of fastening is thus not seen. The "heading joints" of flooring boards may be left square, as at *a* in fig. 5; splayed, as at *b*; or "grooved and tongued," as at *c* in same figure. The diagram *a* in fig. 6, shows the mode of nailing down the heading joints, as at *c* in fig. 5, by the nail or brad driven in an oblique direction. Flooring boards vary in breadth from 5 to 9 inches and broader; the narrowest of these make the best flooring boards, as they are less apt to warp and become hollow than broader boards. The thickness varies from $\frac{3}{4}$ of an inch to two inches. Deal boards are generally 1 to $1\frac{1}{4}$ inches in thickness. The

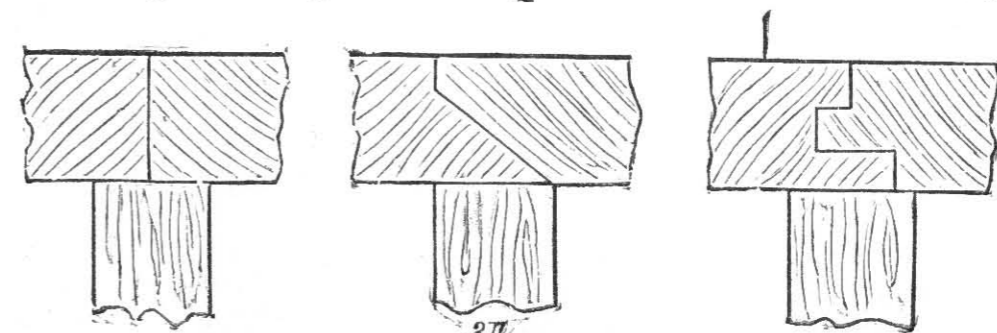

Fig. 5.

upper surface of the boards, after "firing up," are planed to an even surface. The joists should be "fired up" perfectly level before the boards are laid down. "Firing

up" consists in laying down flat and thin slips of wood on the surfaces or upper edges of such joists as happen to be below the proper level, the object being the attaining a uniform surface. Flooring boards are not usually finished off quite level on the surface, the central part being higher than the sides by a height of from half-an-inch to one inch and a half; ceilings should also be finished off higher in centre than at sides. This admits of the "settlement" which usually takes place in all buildings, ultimately bringing the surfaces as level as possible. The edges of the boards must be shot and squared, and brought to a uniform edge before they are tongued and grooved.

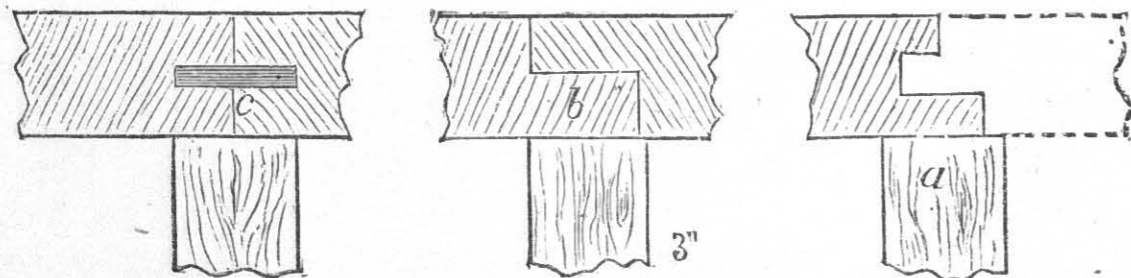

Fig. 6.

3. Skirting Boards.—In order to conceal the joints where the flooring boards butt up against, or approach to the wall, and otherwise to add to the finish of the room, boards more or less ornamented with mouldings, and of greater or less depth, are fixed round the walls of the room at their lower parts where they join the floor. If this finish is made up with a board comparatively narrow, and finished with a moulding of a simple character, the arrangement is known as a "skirting board," if the depth is considerable, and finished with a base and a projecting cornice, it is called a "dado," or "plinth." The reader will find this, the more complicated form, illustrated in the "Advanced Course," the simpler form of finish to

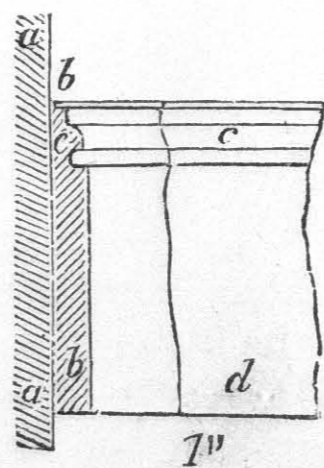

Fig. 7.

the edge of a floor—namely, the "skirting board"—being only illustrated here, as in fig. 7, in which *aa* is part of the timber to which the skirting board, in section, is secured, finished with a moulding at *c*. The drawing on the right is an elevation of the part to the left, or showing the skirting board at the end of the room looking towards it, the sides *aa* being supposed to be at the left. In fig. 8, is illustrated a deeper skirting board than in fig. 7. The lower part, *aa*, is grooved into the flooring boards at *b*, the upper *c* being grooved into *aa*, and fixed to the "ground"—a piece of wood so called secured to the wall—*d*; *e*, the lower ground or fillet; *f*, the plaster; *g*, the wall. In the drawing to the right, the upper and moulded part, *a*, is grooved into the lower part, *b*; *c*, the plaster, keyed at *d* into the ground, *de*. The groove at *b*, fig. 8, is to prevent the dust, &c., from entering the room between the joints and getting behind the skirting board. In place of this a fillet, *e*, is sometimes used. The thickness of the skirting board varies from $\frac{3}{4}$ of an inch to one inch; the depth, from 4 to 6 inches to one foot. The "ground," as *d*, fig. 8, regulates the thickness of the plastering, and should be accurately fitted so as to present the sides vertical, the edge horizontal; the usual thickness is an inch; the

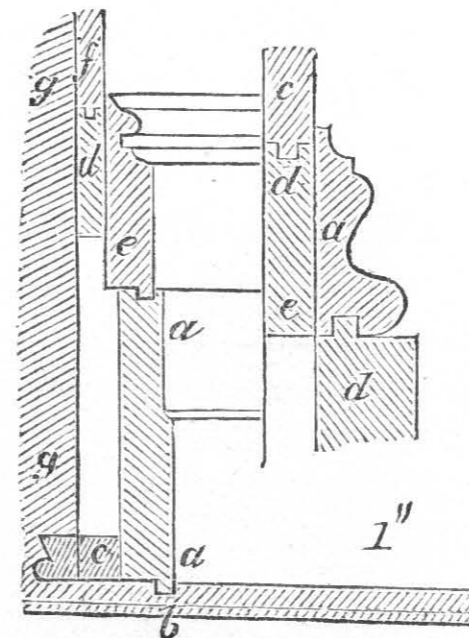

Fig. 8.

plaster being keyed into the "ground," as at *d* in fig. 8, or the upper edge of the ground may be bevelled or splayed off to serve it as a key for the plaster. The fitting of boards of the skirting boards to an irregular surface as that of a floor, is sometimes described as "scribing."

4. Joining of Timbers in Floors.—Fig. 9 illustrates a method of joining the end of a "flooring joist," *a*, to a wall plate, *b*; a groove, as *c*, being cut out in the face of

the wall plate, to allow the lower edge of the joist to pass into it, the depth of the groove, as at *d*, being equal to the

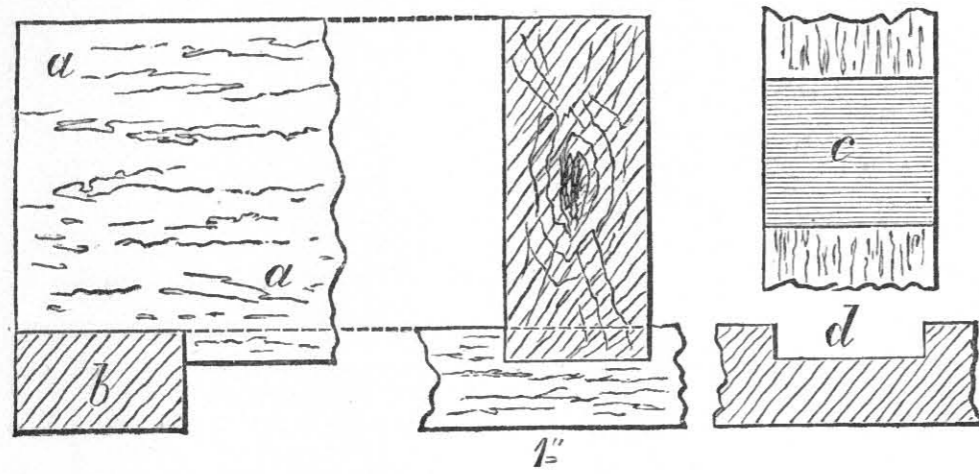

Fig. 9.

depth to which the joist is to enter. In fig. 10 another method is illustrated, a part being cut out on the

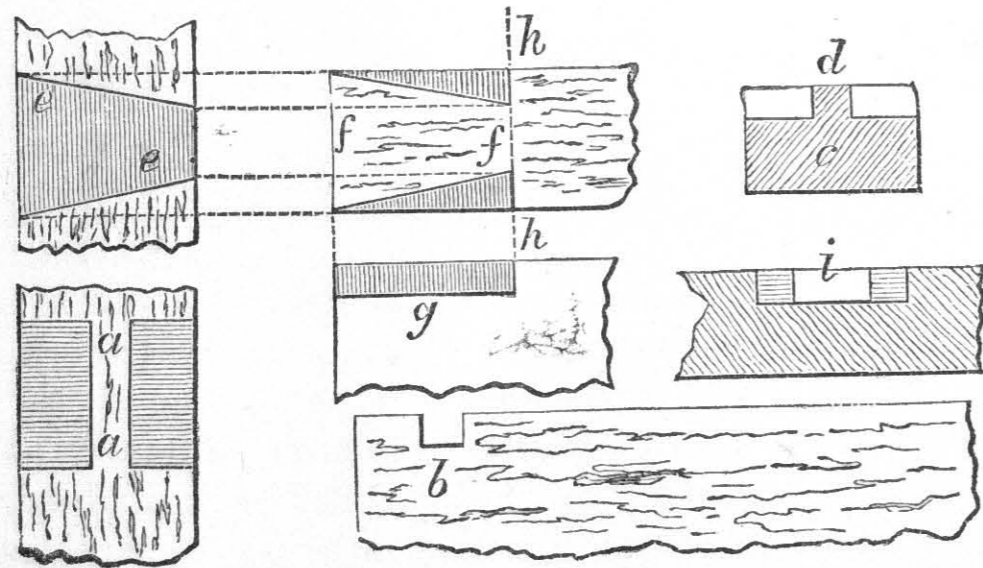

Fig. 10.

face of the wall plate, as in fig. 9, of same width as the thickness of the joist, but a rib, *a a*, is left in the centre, across its breadth; this goes into a groove, *b*, cut in the lower edge of the joist, and of the same depth as the rib, *a a*; a cross section of the wall plate is shown at *c*; *d* showing the rib *a a*. Dovetail joints are sometimes used in connecting joists with wall plates, the best form being that illustrated in fig. 10, well known as the "swallow-tail" joint. In this a part is cut out in the upper face of the wall plate, as at *e e*, the end of the joist

on its lower edge being formed of the corresponding shape, as at *ff*; the side elevation of this is shown at *g*, and a cross section on the line *h h* at *i*. Wall plates are joined together in the direction of their lengths by the "half lap" joint at *ab*, fig. 11, and at the corner of the wall,

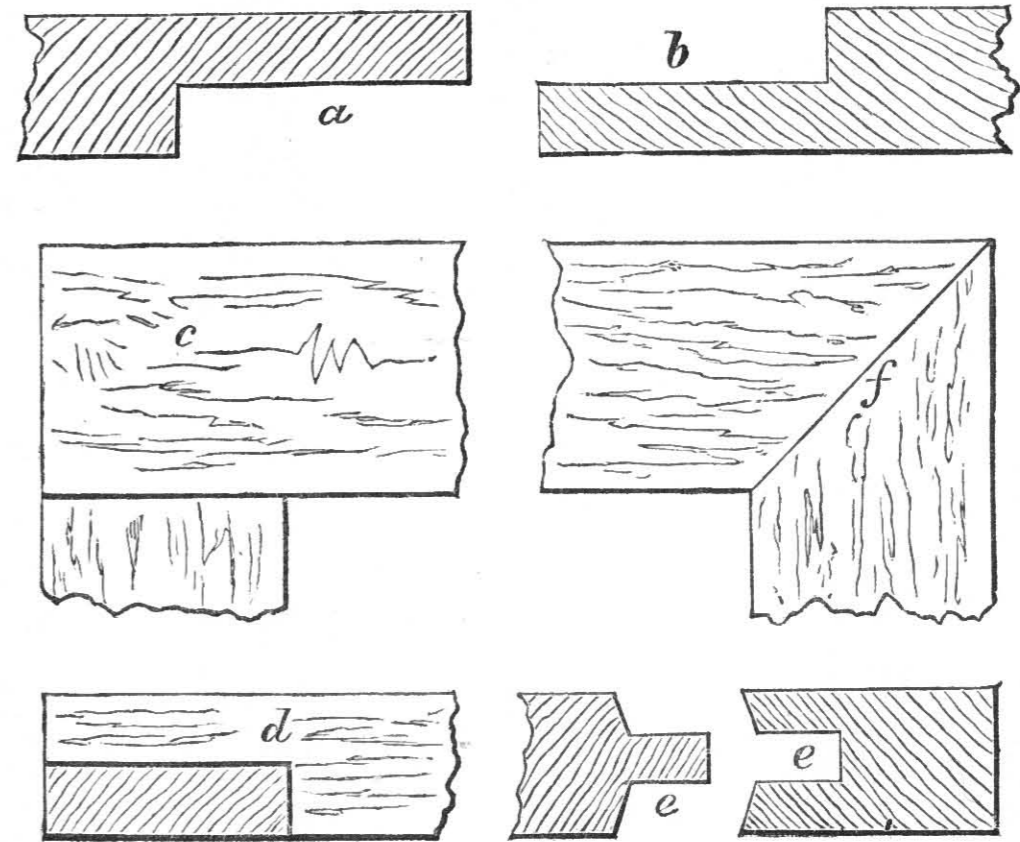

Fig. 11.

as at *c*, by the same half lap joint, of which a side elevation is at *d*, one of the plates at *e*, or they may be joined by the "mitre" joint, as at *f*. Joists are jointed to "trimmer joists" (see fig. 9, Plate IV.), by the joint, in fig. 12; the

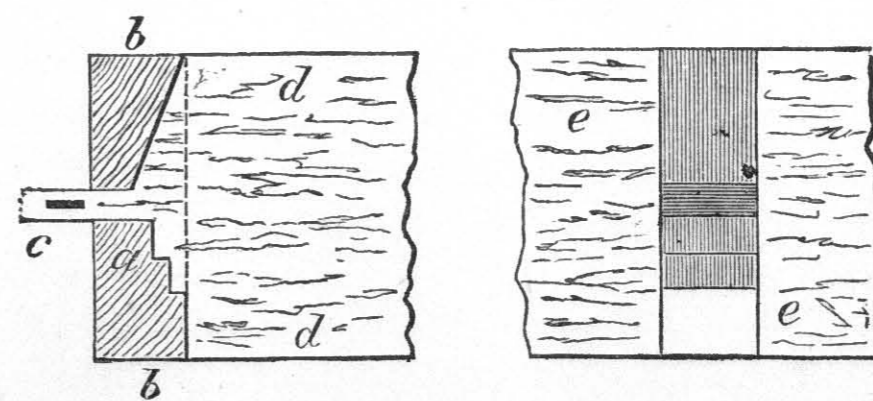

Fig. 12.

tenon *a*, in place of stopping short as at the dotted line, may be extended through the trimming joist, *b b*, as at *c*, and secured by a "pin" as shown; the front of trimmer is shown at *e e*, with the joint cut into its face. The ends of "binding joists" are secured to the

faces of "girders" by a joint of the same kind, which is called a "tusk tenon," as illustrated at *ee* in fig. 11, Plate IV. The usual depth of the tenon, *e*, is one sixth of the whole depth of the binding joist; and the plate of the tenon, *e'*, is one third of the depth of the joist measured from its lower side. The "ceiling joists," *c*, fig. 4, Plate V., are joined to the "binding joists," as shown in fig. 13, where a notch, *a*, is cut out of the lower edge of the binding joist, *b*, into which the ceiling joist, *c*, is passed; *d d* shows the under side of binding joist with notch, *e*, cut out of it; *f*, cross section of do., with ceiling joist, *g*. Another method is adopted in which a chase, or sunk part, is cut, in a horizontal direction, out on

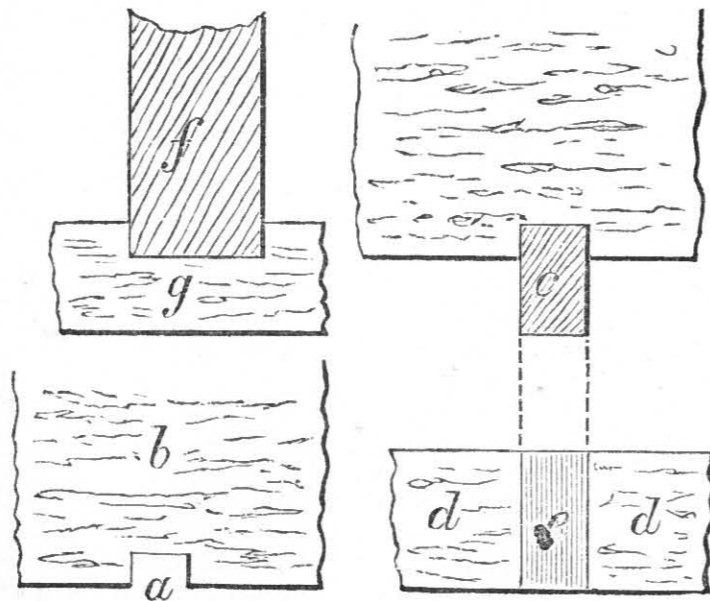

Fig. 13.

one face of the binding joist, near its lower edge, the end of the ceiling joist, *a*, being provided with a projecting part or tenon passing into the chase or mortice, *ff*.

5. Lengthening of Beams.—Where "tie beams" are required of such lengths as prevent them being in one piece, two beams are lengthened by joining them in various ways. We shall at present illustrate one or two of the methods in use, describing others in a succeeding part of this volume. The simplest and the strongest mode of joining two timbers together in the direction of their length is what is known as "fishing." In this the two beams, *a* and *b*, fig. 1, Plate V., to be joined, have their ends carefully squared off, and made to butt against each other at *cc*; they are kept together and secured by the flat pieces of timber, *dd*, *ee*, one placed at the upper, the other at the lower edges of the two beams; bolts, *ff*, pass through the "fishing

pieces" *dd ee*, and the beams *a b*, and are secured by nuts at the end; the nuts should be screwed tightly up, as on these depend the strength of the joints. As they are apt to be incrustated into the wood, plates of iron are sometimes placed beneath the bolt-heads and the nuts, or in place of the fishing pieces being of timber, as in fig. 1, they are of iron, as shown in fig. 8, at *aa*. Usually two fishing pieces are employed, as in fig. 1, Plate V., and shown in section in fig. 4; in some cases, however, fishing pieces are placed at the sides of the beams, thus enclosing them, as it were, and as illustrated in fig. 5, where *a* is the beam, *b* the lower, *c* the upper, *d* the left hand, *e* the right hand fishing pieces, and secured by the bolt and nuts. As said above, the method of "fishing beams" is the strongest employed, but it is obviously unsightly and clumsy, in consequence of the projecting parts as *dd ee*, fig. 1, Plate V. To avoid this, the fishing pieces are sometimes let in to the surface of the beams wholly, as at *bb*, fig. 8, Plate V., or partially, as at *cc*, same figure; but this method, although adding to the sightliness of the joint, greatly takes from its strength. Other methods are, therefore, adopted where appearance can be gained without sacrificing the strength of the joint too much. The principal upon which those other joints are made is that known as **scarfing**, which enables the joint to present a smooth, or rather flush appearance on all sides. The simplest form of scarfed joint, known as the **half lap**, with flat or rectangular "tables," by which term the projecting parts or scarf joints are designated, is illustrated in fig. 10, Plate V. In this a part is cut out at the end of each beam, equal in depth to half of the full depth of beam, and of length equal to the required length of scarf. The two ends, when brought together, form the joint, as in fig. 10, the projecting part of one, as *a*, falling into the recessed part, *b*, of the other. The two are secured together by the timber or iron plates *cc*, *dd*, and by screw bolts and nuts. The plates are better when extending beyond the ends of the

joints, as shown by the dotted lines. The iron plates should be provided with angular ends, as shown at *d*, in fig. 8. A very common form of scarfed joint, with angular or oblique "table," is illustrated in fig. 14, where the meeting faces of the two beams, *a*

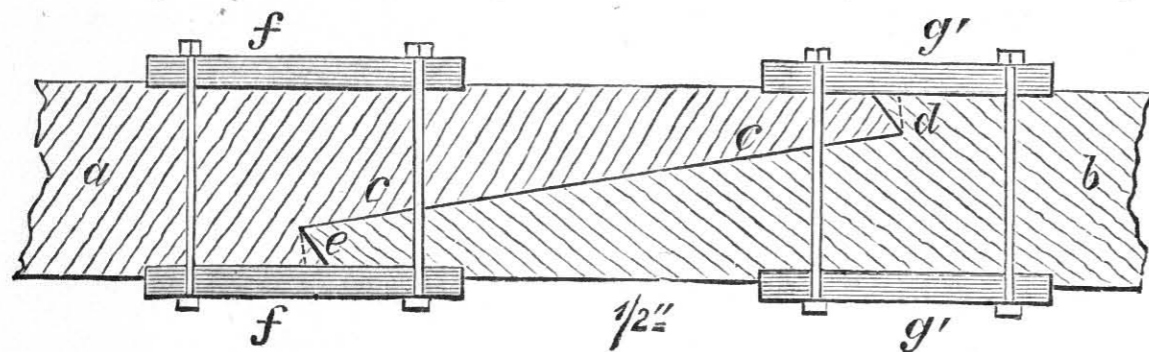

Fig. 14.

and *b*, is oblique, as at *c c*; the ends being indented angularly, as at *d e*; the two being secured together by the plates, *f f*, *g g*; a better form of fishing plate being, however, as illustrated at *a a*, fig. 8, Plate V., the plates extending beyond the joints, as in dotted lines in fig. 10, Plate V. Another form of scarfed joint, with two tables, is illustrated in fig. 15,—*a b*, the two beams; *c c*, the

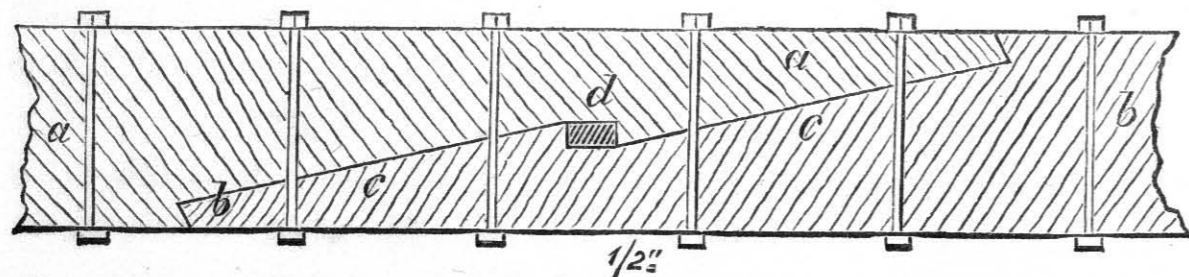

Fig. 15.

oblique tables. In addition to the screw bolts, and nuts, and plates, *d d d*, a wooden "key," *e*, is driven into a groove cut to receive it; the key is of hard wood. Keys are sometimes added to the scarf with plain table, as in fig. 10, Plate V., at the dotted lines *e e*.

6. Increasing the Depth of Beam.—Where beams are required to be of greater depth than can be conveniently obtained by a single beam, two beams are laid edge to edge, and secured in various ways. Fig. 16 illustrates one method known as **cogging, caulking,**

or **keying** A series of grooves, as *a a*, fig. 17,—which is a plan of the upper edge of the lower beam, *b b*, in fig.

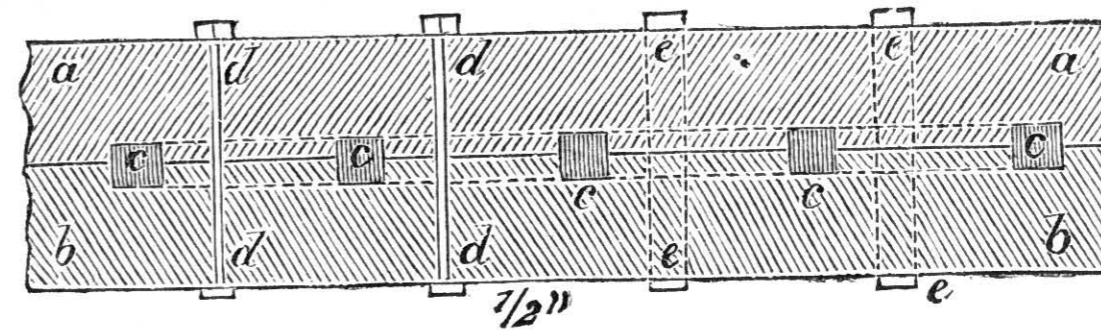

Fig. 16.

16,—are cut in the edges of the beam, at equal distances, as shown, and keys or cogs, *c c*, driven into the grooves. These prevent all lateral or side movements of the two

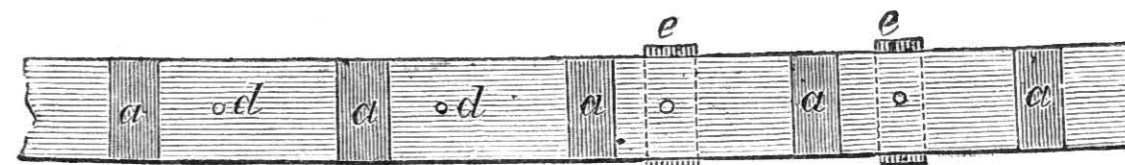

Fig. 17.

beams, *a a*, *b b*, upon one another; and the beams are secured and kept together vertically by the screw bolts, *d d*. In place of these, straps, as *e e*, are sometimes employed. These are also sometimes used in place of bolts in scarfing of beams, already illustrated in Plate V. Fig. 2, Plate V., is the plan of upper edge of the fished beam in fig. 1; fig. 9 the plan of fig. 8; fig. 11 plan of fig. 10; fig. 6 section of fig. 8, on line *a' b'*; fig. 7 section of fig. 10, on line *a' b'*. The scale to which all the drawings in Plate V. are drawn is "half-inch to the foot."

7. Increasing the Thickness of Beams.—When beams are required to be of great thickness, in place of employing one very thick beam, two beams are used, laid face to face, and strengthened either by inserting a **fitch** or plate of wrought iron between the two beams, and securing them together by screw bolts and nuts, or by what is called **trussing** them. These methods are illustrated in Plate VI., fig. 1, being part elevation of a "fitch" beam (sometimes also called a "sandwich"

beam), *a a*, the timber beam, with wrought-iron flitch, *b b*, $\frac{5}{8}$ " thick. The two beams shown at *a a*, *b b*, in figs. 2 and 4,—plans of top of beam at its ends,—are secured together by screw bolts, which pass through the beams, *a a*, *b b*, and the flitch *c*, as at *d d*. Fig. 3 is a cross section. The scale of this drawing is half-inch to the foot. Fig. 5 is a "trussed beam." The beam to be trussed is usually made out of two beams formed by cutting up a beam in the direction of its length, and reversing the sides, so that what formed the inside of the beam is turned to the outside. This plan of sawing up a single beam to form either a flitch beam or a trussed one is very good, as it exposes the central part of the wood to the action of the air, and shows defective parts. In fig. 6, *a* and *b* are the two beams, and fig. 5 shows the arrangement of the truss between the two. This consists of a central stud of wrought iron, *a*; the head, *b*, of which is formed with a plate which lies in the upper edges of the beam, as shown in plan, fig. 7, at *a*; the lower part is provided with a screwed part and a nut, *c*, for tightening up the stud; the nut presses upon a small washer plate as shown. The upper part of the stud, *a*, fig. 5, Plate VI., is made with two angular butting faces, *d d*, against which the upper ends of the struts or braces, *e e*, of hard wood or of iron butt, the low end butting against the part *f* of the stud, *g*. This stud is provided with a bolt, *h*, to resist the pressure and keep it in place; or the stud is made wider, and let in at both sides into grooves cut in the faces of the two beams. The whole parts are further secured by bolts, *i i*. Fig. 8 is part elevation; fig. 9 part plan; and fig. 10 section of a beam trussed in the queen post principle, a straining piece, *a a*, being placed between the two studs, *b b*; *c c*, the struts. In Plate XI., fig. 1, the elevation of a method of forming girder beams of greater depth than could be made out of a single beam or of two beams, is already illustrated. This, as the reader will perceive, is an open beam, and is sometimes called

a "trellis beam" although the more correct form of a trellis beam will be found illustrated in the *Advanced Course, Building Construction*, in this series. In fig. 1, Plate XI., the open beam is made up of a sill, or lower beam, *a a*, this may be according to the span or bearing of the beam—either in one length, or if made up of one or more lengths, these may be scarf jointed as already illustrated. The "head," or upper beam, *b b*, supported at intervals by studs, posts, or puncheons, or short beams, *c c*, placed vertically. Between the beams, braces or struts, *d d*, are stretched; butting at the ends against the sills, *e e*, heads, *b b*, and studs, *c c*, as shown. The heads and sills are further secured together either by screw bolts and nuts as shown at *e e*, or by straps at *f f*. Fig. 2 is a vertical section through line *a' b'*, showing how the posts, *c c*, are mortised into the head, *b*, and sill, *c*, and secured by the bolt, *e*. Fig. 3 is a section on the line *c' d'*, showing the crossing of the struts or braces, *d d*, which are half lapped into each other at the point of crossing, *f f*, the strap. Fig. 4 is a horizontal sectional plan in the line *e' f'*; fig. 5 is a plan of upper side of sill, *a a*, showing the mortise, at *b c*, into which the tenon at foot of struts, as in fig. 8 at *a* (in side elevation), and at *b* (in plan) pass. At *a*, in fig. 7, is shown the mortise in which part of the tenon or strut, as *c d*, fig. 8, passes. Fig. 6 is a plan of upper side of one of the studs, *c c*.

8. **Brestsummers, or Bressumers**, are beams of considerable thickness and depth thrown across wide openings, as that of a shop front, to support breast of front wall, built above the opening. They may be strengthened by one or other of the methods just described, and should have a bearing of at least nine inches in the wall at each end. "Templates" of stone, or timber, should be used, on which the ends of the brestsummer rests; a very usual size for the brestsummer is 14 in. by 12, or 14 in. by 9. A lintel is a beam or small bressummer thrown across a narrow opening made in a wall, as that for a window or door opening of

the usual width. It is the ordinary practice to allow one inch in depth for each foot of width of opening; a good proportion for a lintel is 7 in. by 5. The bearing in the wall should be nine inches. If the wall is thick, two or more lintels are used; and it is good practice to give the lintels a bearing upon oak templates, which should stretch across the full breadth of wall.

9. Partitions.—When the partitions of a house are formed of timber, they are finished in one of two ways. When the spaces between the various timbers forming the partition are filled up with bricks, the partition is termed **bricknogged**; if the spaces are not so filled up, but left void, and these and the timbers first covered with lathing, and the laths then plastered, the partition is termed a **“quarter”** or **“quartering.”** In some cases a quarter partition is not covered with laths and plaster, but simply with boarding, painted or papered on its outer surface; the boards being tongued and grooved. The following are the names of the various members which make up the assemblage of timbers of a partition, as illustrated in fig. 3, Plate VII.—*a a a*, the “sill;” *b b b*, the “head;” *c c c*, the “posts” or “quarterings;” *d d*, the “struts” or “braces;” *e*, the “head at a door opening;” *f f*, the “filling-in pieces” or “single quarterings.” Partitions are of various kinds. Fig. 2 illustrates part of one of the simplest forms, in which there are only “sill,” *a a*; “head,” *b b*; “post,” *c*; and “filling-in pieces,” *d d*; this is called a **“framed partition.”** Fig. 3 is a **“framed and braced partition,”** as is also the upper part of fig. 1. When folding doors or a large opening in the centre of a partition are required, as at *a* in fig. 1, Plate VII., or where the partition is to support a second partition above it, as in the same figure, the lower partition is to be **“trussed”** in the same manner as a roof is trussed (see **“Roofs”** in this chapter); and the partition is then termed **“framed, braced, and trussed,”** or simply a **“trussed partition.”** This is illustrated in fig. 1, Plate VII., where the trussed part

is at *g g*, *h h*, *i i*. The other parts are the same as described in fig. 2 of this Plate. The **“truss”** in fig. 1 is what is called a **“queen post”** truss (see **“Roofs”**); *g g* corresponding to the tie beam; *h h*, the queen posts; *i i*, the **“struts”** or **“braces;”** *j j*, the **“straining beam.”** Partitions are sometimes made to rest upon the floor joists, but this should be avoided in good and sound construction; as, if done, the joists in settling, which they do in all cases more or less, will allow the partition to drop, and the result will be a crack or joint opening at the line of the cornice, or where the plaster of the partition joins that of the ceiling. The best plan is to support the upper partition sill upon upright blocks or **“puncheons”** of wood, same thickness and depth as the flooring joists, these blocks resting upon the head of the partition below, as illustrated in fig. 4, Plate VII.; where *a a* is part of **“head”** of lower partition; *b b*, part of **“sill”** of upper do.; *c c*, **“flooring joists;”** *d*, **“puncheon”** or block of wood, which may be placed between the joists, or close to them, as at *e*. Complete settlement of all the timbers

should be allowed to take place before plastering of a partition is begun to.

10. Joining of Timbers in Partitions.—These are now to be illustrated. Fig. 18 shows two methods of joining the **“post,”** *c*, fig. 1, Plate VII., with the **“sill,”** *a*, as at the end, *m*; the end of the post, *a*, as fig. 18, being tenoned, as at *b*; this passing into a mortice made in sill, as at *c*; or the tenon on end of post may be lengthened, so as to pass to the under edge of sill, a groove being

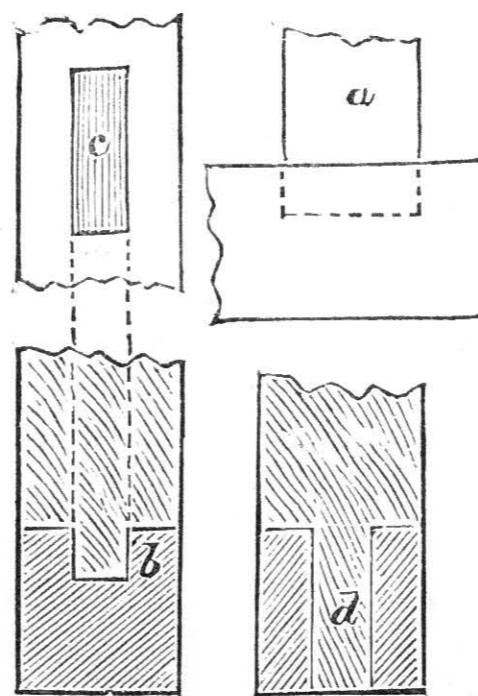

Fig. 18.

made in the end of sill, as shown at *d*. The junction of the post, *c*, with sill at joint, *n*, fig. 1, Plate VII., is made by mortice and tenon joint, as in fig. 19, where *a* is the

“post,” *b b* “sill,” *c* the “tenon,” passing into the mortice *d*. The mortice and tenon joint may be much strengthened by what is called fox-tailing. In this the sides of

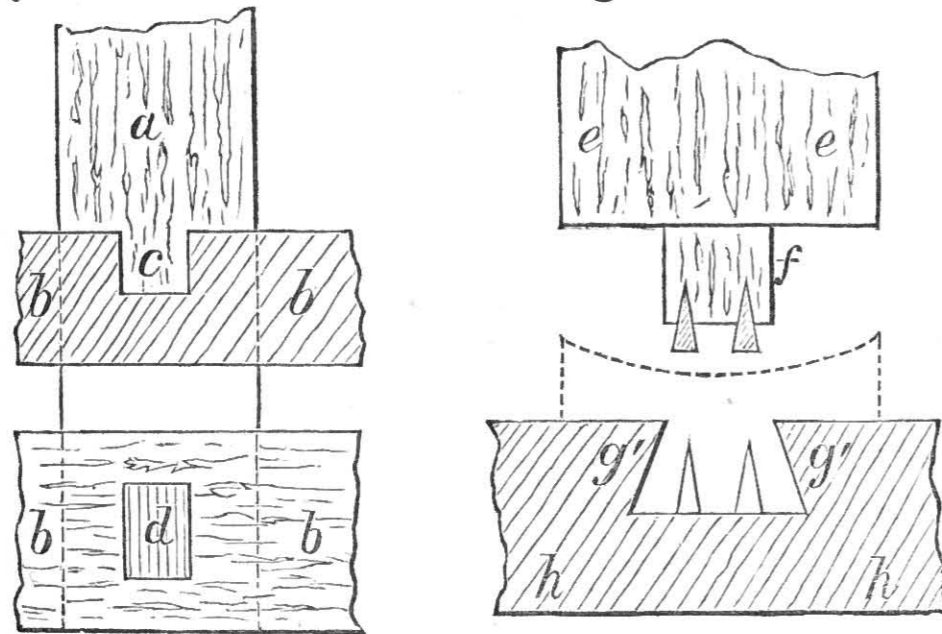

Fig. 19.

the mortice are made with sloping sides, as at *g g*, in fig. 19; and the ends of the tenon, *f*, are provided with small wedges, partly driven into the end of the tenon. When the post, *e e*, is driven into the sill, *h h*, the small wedge,

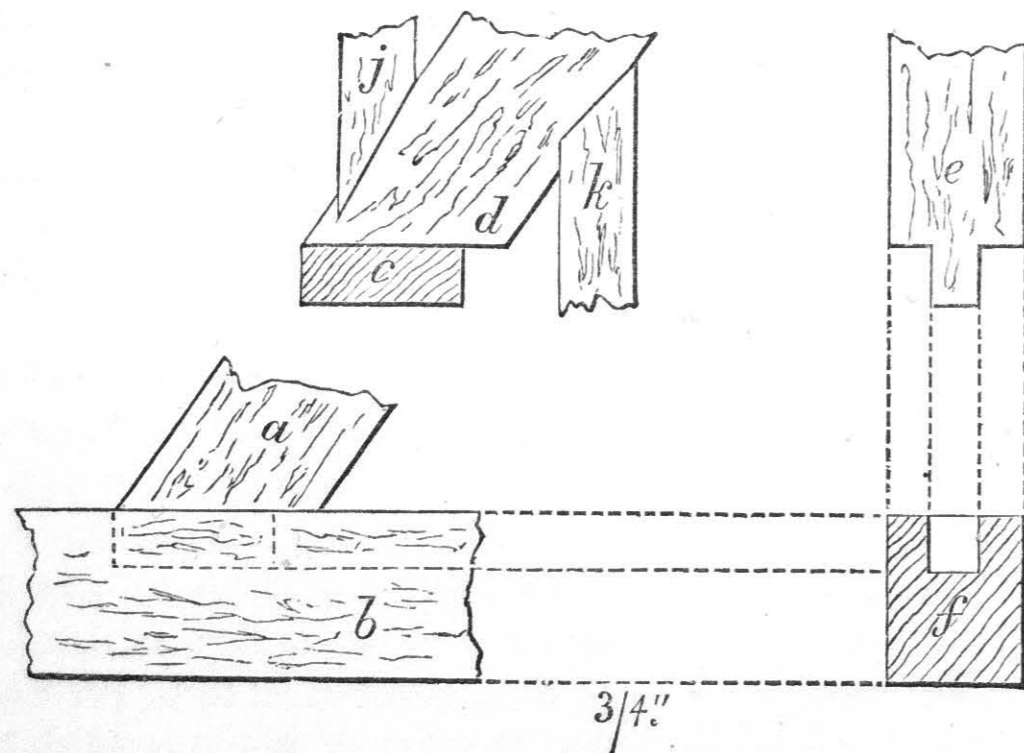

Fig. 20.

being forced into the tenon, causes the sides to bulge out, and fill up, or partially fill up, the mortise. Fig.

20 shows a method of joining the end of the “brace” or “strut,” *d*, fig. 1, Plate VII., with the sill, *a a*, as at the point *o*; *a*, fig. 20, being the strut; *b*, the sill; the tenon, *c*, being made with a shoulder or part cut out, as at *d*; *e* is an edge view of the strut; *f*, a cross section of the sill. The junction of the “filling-in pieces,” as *f f*, fig. 1,

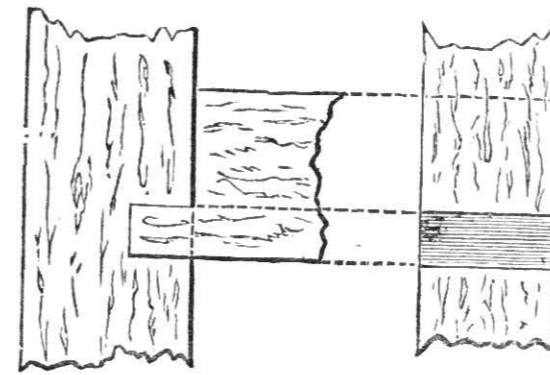

Fig. 21.

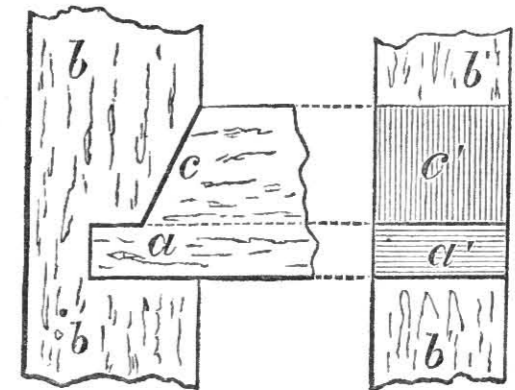

Fig. 22.

Plate VII., as at *p* and *q*, are shown at *j* and *k* in fig. 20, *j* and *k* corresponding to *p* and *q*, *d* to *d*, and *c* to *a*, fig. 1, Plate VII. The head, *e*, of door opening, fig. 1, Plate VII.,

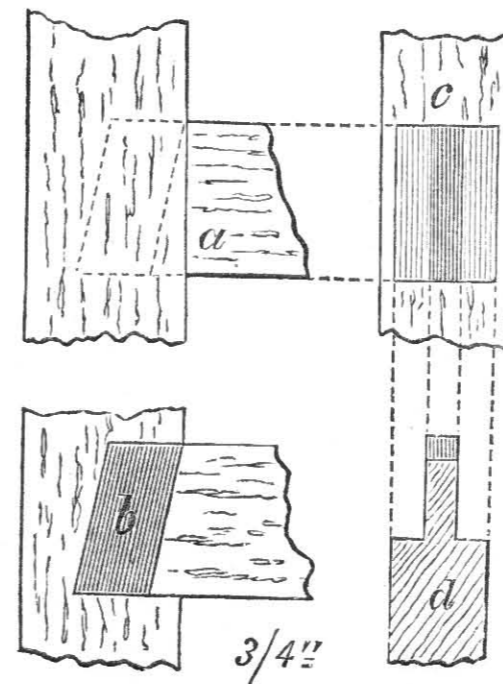

Fig. 23.

may be joined to the posts, *c c*, by the method shown in fig. 21, or fig. 22, where *a a* is the head, *b b* the post. The method in fig. 23, at *a*, is that most usually adopted. The end may be terminated by a tenon, as at *b*, fig. 23, this going into a mortise made in the post. The edge view of the post is shown at *c*, with the sloping shoulders of notch and the mortise shown. A section of the “head” is shown at *d*.

11. Roofs.—The simplest form of roof is what is called a **shed** or **lean-to** roof, in which the rafter is supported at one end on the front wall, *a*, and at the other on the back wall, which is higher than the front, and which may be represented by the dotted line *b c*, in fig. 3, Plate IX.; the end of this forms a triangle, of which the rafter, *d c*, forms the

hypotenuse. Where the walls are of equal height, as $a f$, fig. 3, Plate IX.; and the rafters, $d c, g h$, are placed at equal angles, the lower end resting on the wall, and the upper butting against each other, or against a board, b , called a "ridge pole;" the roof is called a "span roof," sometimes a "couple roof." This is only used for roofs of very small span, and supporting a very light covering, as boards or asphalted felt, as there is no provision made to prevent the ends, $d h$, of the rafters separating, or pressing the walls, $a f$, outwards. This tendency is prevented in the next simplest form of roof, called a "collar beam roof," shown to the right of fig. 3, in Plate IX., by the addition of what is called a "collar beam," i , which stretches across from rafter to rafter, at a height of about one-third of the rise of the roof, and is secured to the face of the rafters by the joint at i ; k is a member called a "purlin," of which more presently.

In fig. 1, Plate VIII., what is called a "king post" roof is illustrated. In this a "tie beam," $a a$, stretches from wall to wall, resting at its ends upon "wall plates," $b b$, built into the wall, $c c$. The vertical central post, $d d$, is called the "king post." The "principal rafters," $e e$, butt against the upper and bevelled sides, $f f$, of the king post at their upper end, and at their lower are jointed to the tie beam at $g g$. The "common rafters," $h h$, butt at their upper extremities against the "ridge pole," i , and at their lower are notched into and supported by the "pole plates," $j j$, which again are notched into the upper face of the tie beam, $a a$. These numbers form an assemblage of timbers, called a "truss," and are placed upon the wall at equal distances from (but parallel to) each other, about nine to ten feet, as shown at $a a$ in plan, fig. 2. The "common rafters," $h h$, fig. 1, and $f f$, fig. 2, are placed between these trusses, at equal distances of generally 14 inches from centre to centre, being supported at one or more parts of their length between "pole plate," $b b$, and "ridge pole," $c c$, fig. 2, by one or more timbers, called "purlins," $k k$, fig. 1, and $d d$, fig. 2. Fig. 3 is part ver-

tical section and edge view of the truss in fig 1, looking towards it in the direction of the arrow, l ; and fig. 4 do., in the direction of the arrow, m . Fig. 5 is part plan of wall; fig. 6 part elevation of wall. "Struts" or "braces," $n n$, fig. 1, Plate VIII., support the "principal rafters," and butt against the lower bevelled sides at the foot of "king post." In fig. 2 the dotted lines, $e e$, show the way in which the boards supporting the slates are carried; or if battens are used for these, they run as at dotted line, e , fig. 2. In fig. 5, $b b$ is "wall plate," $c c$ the "gable wall," c "side wall," $h h$ "common rafter," $i a$ "ridge pole." (See fig. 1, Plate V.)

In fig. 1, Plate IX., we give an illustration of a "queen post truss," used for wider spans than the king post truss, or for cases where a central space is required in the roof. $a a$, the "tie beam;" $b b$, "wall plates;" $c c$, the "walls," $d d$, the "queen posts;" $e e$, "straining beam;" $f f$, "straining sill;" $g g$, "principal rafters;" $h h$, "common do.;" $i i$, "pole plates;" j , "ridge pole;" $k k$, "purlins." Fig. 2 is edge view of the truss. Where the gable or end wall of a house is carried up to form with its sides angles of the same slope as that of the truss, the "purlins" terminate at, and are supported by, the walls, and sometimes project beyond them. Fig. 1, Plate X., illustrates the arrangement of timbers in a span roof with gable end in one half of the drawing, to the left of the central line, $a' b'$; the "principal rafters" are indicated by double lines, $b b$; the gable wall, $c c$, is carried up parallel to these, and finished at the same angle; $d d$, the "ridge pole" or "ridge piece;" $e e$, the "purlins;" $f f$, "wall plates;" $g g$, "common rafters." The half of the diagram in fig. 1, Plate X., shows plan of roof with flashing, $h h$, at ridge, "gutter" at $i i$; $k k l l$, lines indicating the slating. In what is called a hip or hipped roof, the ends of the wall of buildings are not gabled, but are terminated at the same level as the side wall. The roof at the end is thus formed at an angle to meet the angle of the roof springing from the sides, as $a c$, fig. 2; b, c , and d , indicating the lines of slating. In the half of the drawing

towards the left of the central line, $a' b'$, $c c$ indicate the "ridge pole;" $i i$, the "wall plates" at side; and h , the "common rafters;" the "principal rafters" being indicated by the double lines; $f g$, the "purlins." The sloping or angular rafters, $f f$, which spring from the corners of the wall, are termed the "hip rafters" or "angle rafters;" the short rafters, to meet the hips springing from the wall plate in the end wall, are called "jack rafters," as $g' g'$.

Fig. 4, Plate IX., illustrates a form of "truss" in which the king post of timber is dispensed with, and a wrought-iron rod or bolt, $a a$, is used; the rafters butt against the ends of, and are passed into hollow parts of a cast-iron "rafter box, b ;" c , "braces;" d , "purlin;" $e e$, tie beam;" $f f$, "wall plates;" $g g$, "pole plates." What are called sometimes "cushion rafters" or "principal braces," are subsidiary rafters, placed close below the principal rafters, to strengthen these when required; their position is indicated at $a c$, fig. 4, Plate X., b being the principal rafter; $a a$, the line of upper edge of tie beam.

12. Covering for Roof Surfaces.—Roofs are covered in this country generally with slates; in rural buildings with tiles; and iron roofs are covered with galvanized iron, zinc, or with slates. We purpose to describe slate covering, leaving notice of other materials to the *Advanced Course in Building Construction* in this series, where also will be found a list of the different kinds and sizes of slates. In

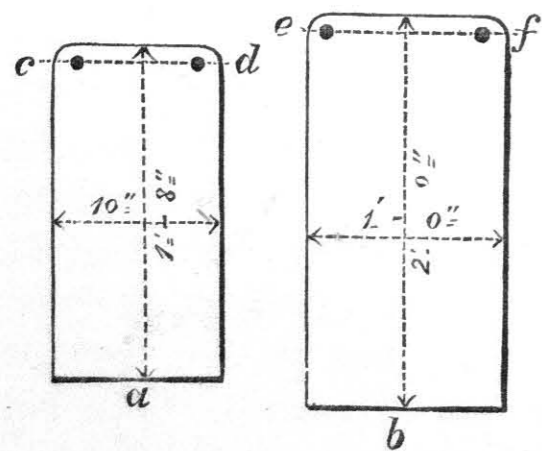

Fig. 24.

fig. 24 we give illustrations of two sizes of slates, known as **countess**, a ; and **duchess**, b ; the size of a being 20 in. long by 10 wide, that of b 2 feet long by 1 foot wide. The upper surface of a slate, that exposed to view when on a roof, is called the "back;" the lower or under edge, the "bed;" the lower edge, a , fig. 25, the "tail;" the upper

edge, b , fig. 25, the "head." Slates are placed on a roof in such a way that certain parts only of their surface are exposed to view, the other part being covered by slates which overlap them; the whole arranged so that they "break joint," as the technical term is, and as shown in fig. 25, where the joint of the lower course, as $c c$, is covered by the solid part of the course, as $d d$. The part exposed to view, as the part between $e e$ of the slate

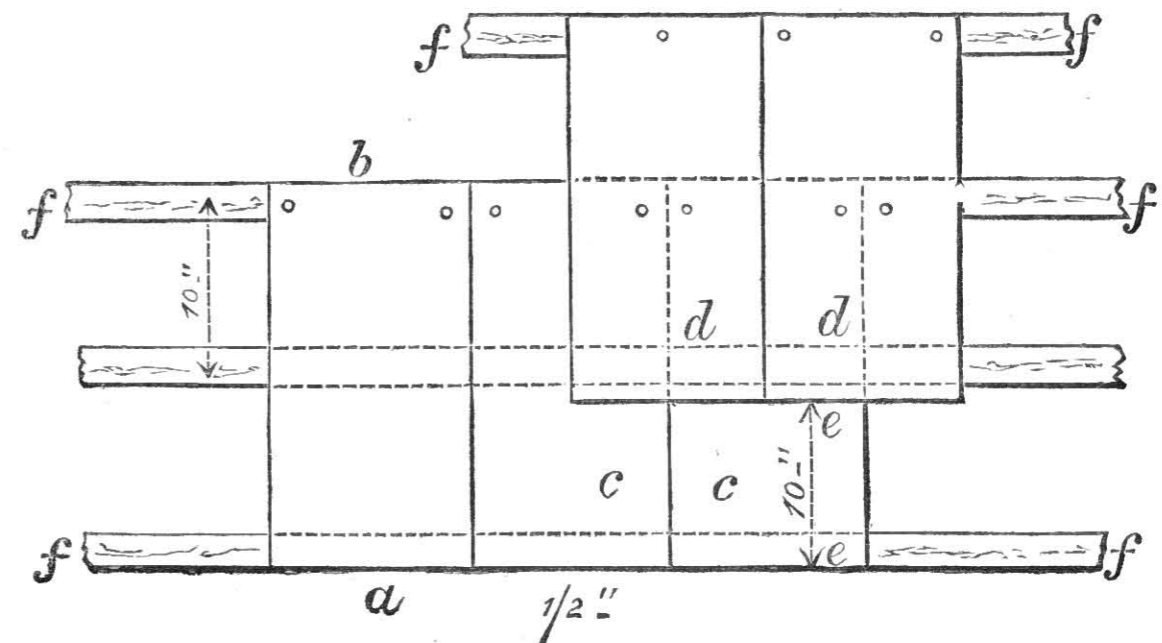

Fig. 25.

above c , is called the **margin**. This varies according to circumstances, and its width, or rather depth, as from e to e , is called the **gauge** of the slated covering of the roof. The **bond** or **lap** is the depth which an upper slate covers or overlaps the plate below it. This "lap" or "bond" is measured from the line $c d$, or $e f$ in a or b , fig. 24, running through the centres of the nail holes, parallel to the "head" of the slate; this line being known as the **nail line**. Before fixing, the slates are trimmed at the edge, and the holes punched as near to the head as possible without incurring the danger of breaking the slate. The slates are fixed either to "boarding" or to "battens," these being secured at intervals to the upper edges of the rafters of the roof. Fig. 26 illustrates the mode of fixing slates to boarding— $a a a a$, the

board nailed to the rafters, *b b b b*; *c c c*, the "slates;" *d d*, the "margin."

If the slates are fixed to battens, which are small timbers 2 to 3 inches wide and three-fourths of an inch in thickness, the distance from centre to centre of the battens is determined by the "gauge" or depth of the margin *e e*, fig. 25. This is found by halving the distance from the

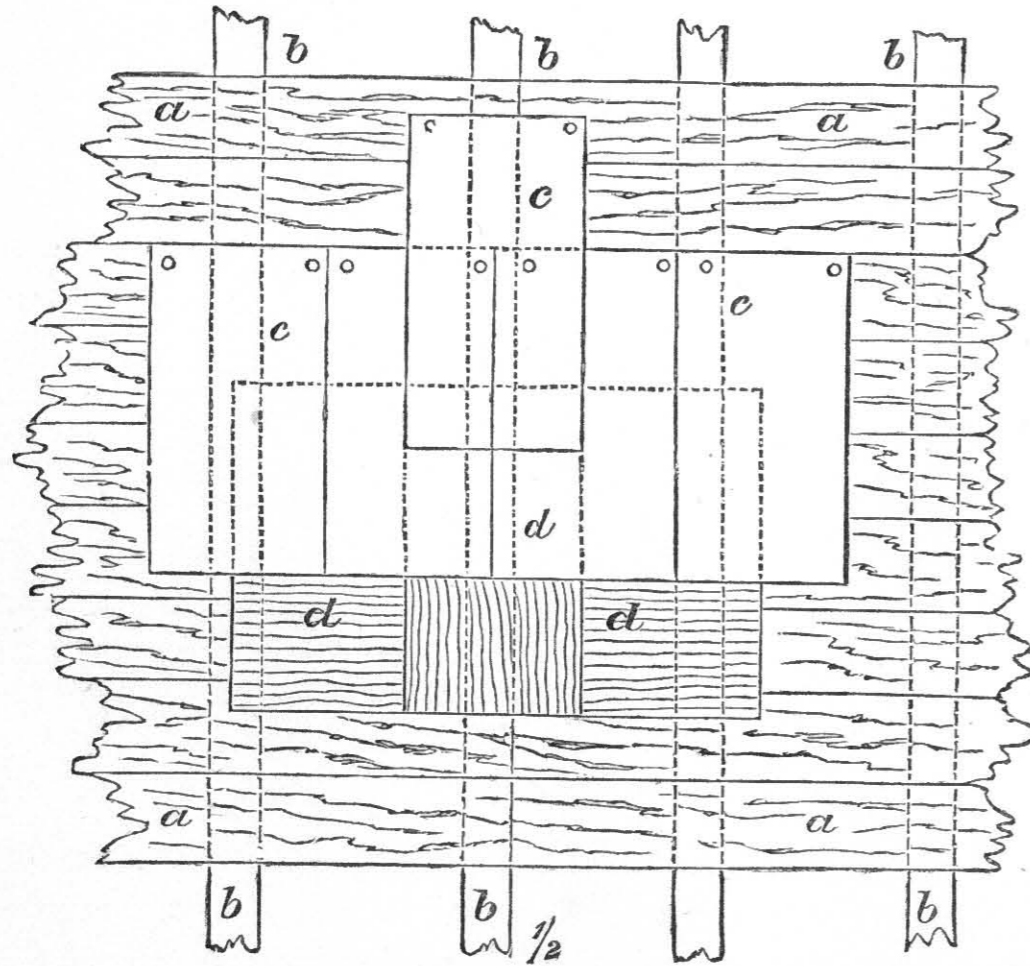

Fig. 26.

"nail line," *c d*, fig. 24, to the tail, *a*, fig. 25, of the slate, deducting from this the width or depth of the "bond" or lap, and dividing the result by 2. Thus, in fig. 25, the slate, *a b*, is a duchess slate, 2 feet long by 1 foot wide. The nail line is 1 inch from head, *b*; this gives 23 inches as the distance from this to the tail, *a*, of the slate; the "bond" or "lap" is fixed at, say, 3 inches, which deducted from 23 gives 20, and this divided by 2 gives 10 inches as the "margin," *e e*, fig. 25, and the distance from centre to centre of the battens, *f f*. Fig. 27 gives the section of the arrangement, where *a a* is

the rafter; *b b*, the battens; *c c*, the slates. In fig. 28, the "tilting piece" or "eaves board" is shown at *a*. This is feather edged, thicker at one edge than at the other, and its office is to tilt up the lower or eaves course of slates; the width of the tilting piece, *a*, is 6 inches; the thickness of lower edge, $1\frac{1}{2}$; and of its upper edge, three-fourths of an inch in thickness.

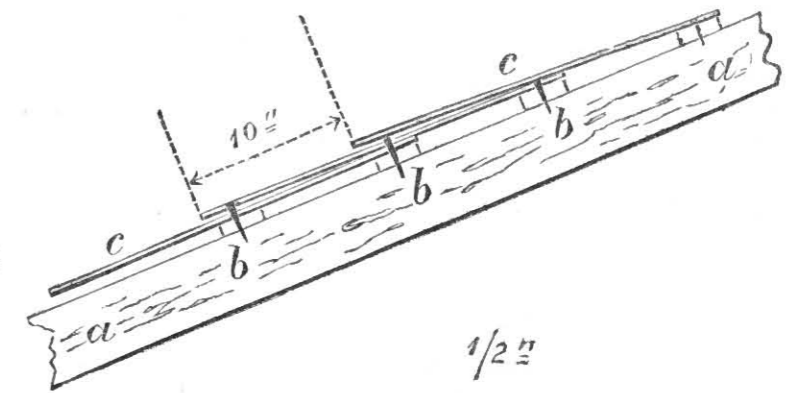

Fig. 27.

In this fig. *b b b*, the battens; *c*, the rafters; *d d e e*, the slates. For lead flashing, and lead work

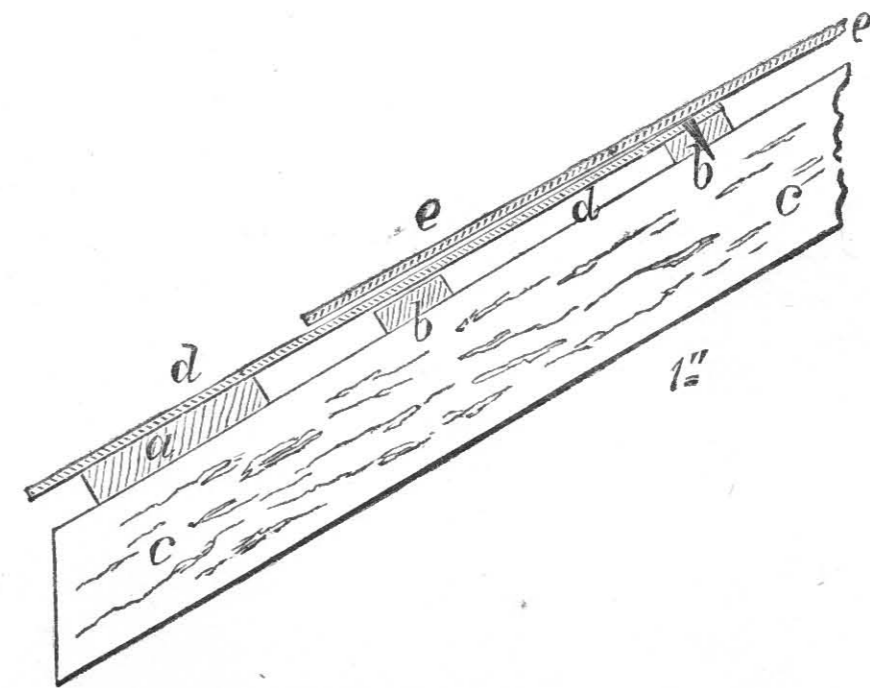

Fig. 28.

generally, see the Chapter in this volume on "Work in Lead and Iron."

13. Weather Boarding.—What is called "weather boarding," used to cover the outside walls, and sometimes the roofs, of sheds, &c., is "feather edged"—that is, with one edge thicker than the other. The thin edge is

placed uppermost, and the boards are placed so that a "lap" of from $\frac{3}{4}$ to 1 inch is allowed.

14. **Gutters of Roofs.**—There are various methods of making these. The simplest is that illustrated in fig. 3, Plate X., the "gutter," *a*, being one formed of cast iron, zinc, or galvanized iron; it is nailed to one end of the rafter, *b*, and the rain from the roof is dropped into the gutter by the lower course of slates, as *c*, projecting a little beyond the face of the rafter, *b*. The diagram to the right is a front elevation of the gutter. The gutter, *a a*, is attached to the end of the rafters so that there shall be a slight fall or inclination in the direction of its length, and towards the "down spout," which leads the rain water to the drain or to the cistern. In fig. 5, Plate X., we illustrate a method of forming a gutter and the eaves of a roof very commonly used; in this, *a a* is the wall; *b*, the "pole plate;" *c c*, the "common rafter." The "gutter," *d d*, is formed as shown; the bottom, *e e*, being tailed into the wall; to the front or face board, *f*, the mouldings, *g*, are secured. The board, *e e*, rests upon the upper face of the cantalever, *h h'*, the outer face of which is moulded, as shown, or the moulded fascia, *h'*, may

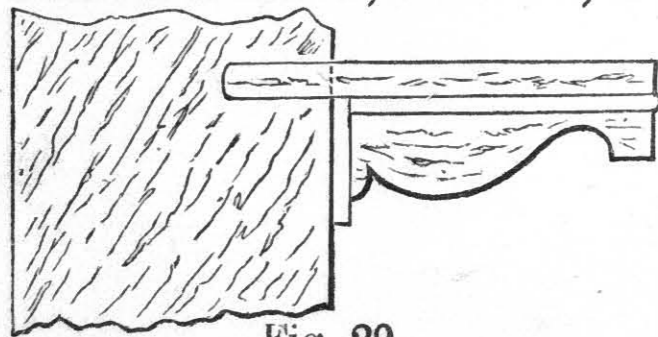

Fig. 29.

be secured to the wood brick, shown by the dotted line, *i*, the cantalever being dispensed with. The drawing to the left is a front elevation of the gutter mouldings, &c. In figs. 29 and 30 we illustrate other forms of "cantalevers," the office of which is to support the eave and overhanging gutter. Fig. 30, properly speaking, is a bracket, the lower end of which is supported by a small stone corbel, *a*, moulded on face, and tailed or built into wall, *b b*; *c c*, a bracket, also tailed into wall, supported at its outer end by the angular piece, *d*, chamfered (see Chapter Third on "Joiner's Work") on its edges, as shown. The angular part between the

gutter is illustrated in fig. 31. In this the gutter, *a*, is behind the front wall, the upper part of which is terminated by the cornice; so that the lower part of roof or eave and the gutter are not seen from the outside; *b b*, the wall; *c*, wall plate; *d*, common rafter; the gutter boarding, *e e*, is supported by the bridging piece, *f*. What is known as a valley, or valley gutter, is illustrated in fig. 32, being used where two span roofs parallel to one another meet in a central point in the "valley;" *a a* is the tie beam,

bracket, *c c*, and corbel, *a*, is frequently highly ornamented with scroll work. In *e e* is an edge or front view of parts *c a* and *e*. What is termed a bridged

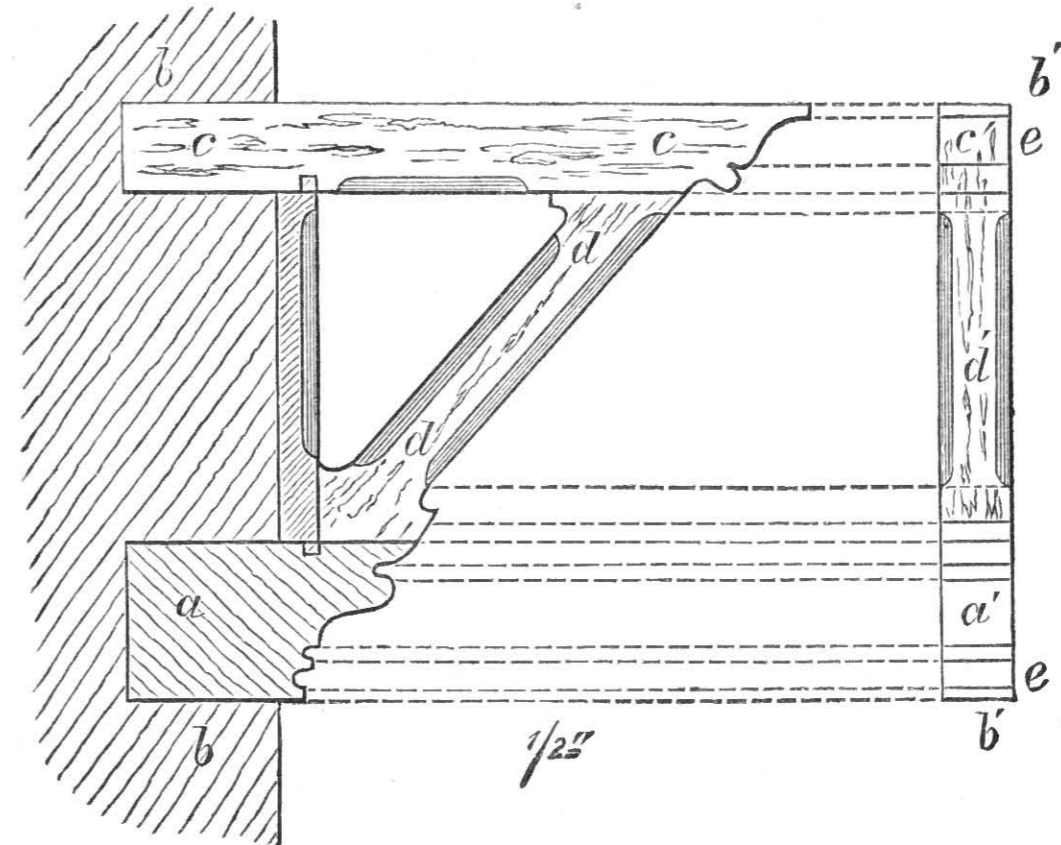

Fig. 30.

gutter is illustrated in fig. 31. In this the gutter, *a*, is behind the front wall, the upper part of which is terminated by the cornice; so that the lower part of roof or eave and the gutter are not seen from the outside; *b b*, the wall; *c*, wall plate; *d*, common rafter; the gutter boarding, *e e*, is supported by the bridging piece, *f*.

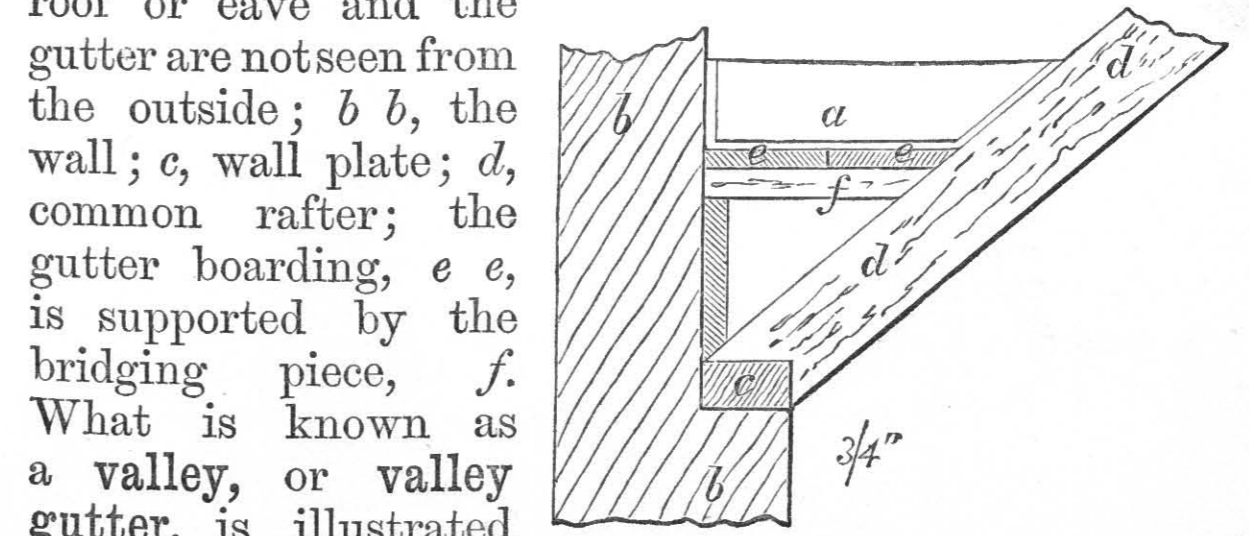

Fig. 31.

where two span roofs parallel to one another meet in a central point in the "valley;" *a a* is the tie beam,

supported in the centre by a trussed partition, part of which is seen at *b*; *c c*, the common rafters, butting against the plate, *d*; *e*, the bridging piece of gutter, which carries the gutter board, *f*. In the *Advanced Course of Building Construction* in this series, other forms of gutters, with details of the parts, will be given.

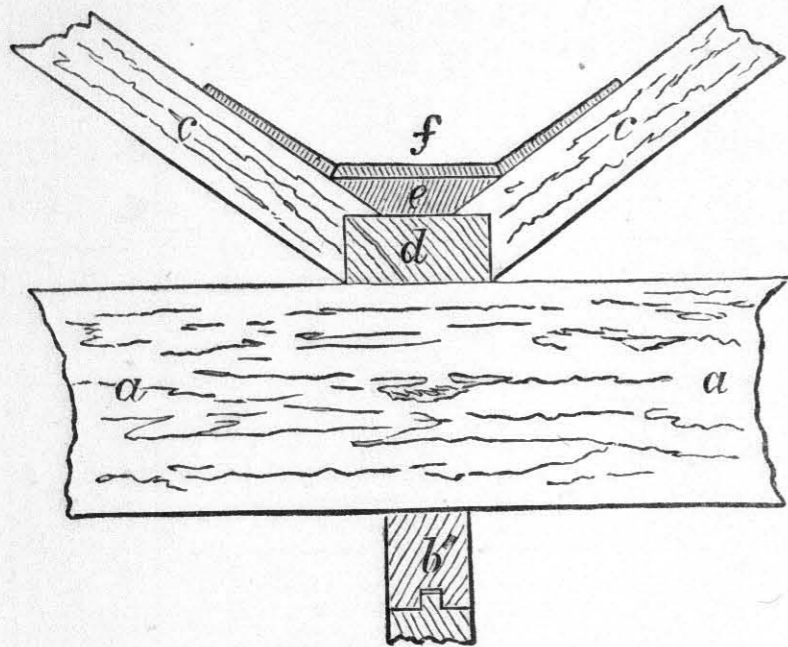

Fig. 32.

The eaves of gabled roofs are frequently finished with cut or ornamented timber, as

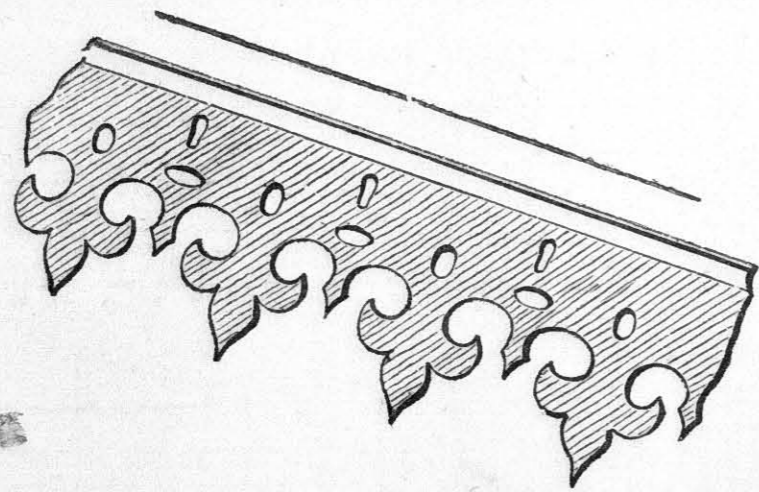

Fig. 33.

in fig. 33, fig. 34, showing an ornamented eaves-

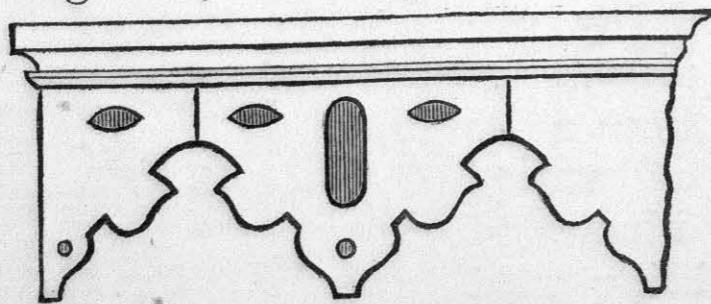

Fig. 34.

board for a horizontal eave. In the *Advanced*

Course, designs for barge board and eaves will be given.

JOINTS USED IN FRAMING OF ROOFS.

15. In figs. 35 and 36 we illustrate **Junctions of Tie Beams with Wall Plates.** In fig. 35,

a notch, *c*, is cut out in the lower or under edge of the "tie beam," *a a*; the "wall plate," *b*, passing into this. In fig. 36, the plan of "cogging" the "tie beam," *c c*, to the "wall plate," *b*, is shown—in this a groove is cut in the

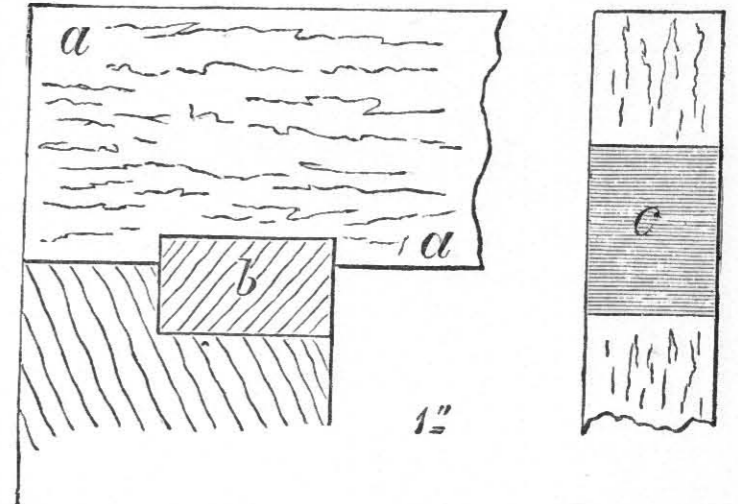

Fig. 35.

face of the "wall plate" at *e e*, with a notch in the lower edge of the "tie beam," as at *f*; a key or cog, *d*, of hard wood is driven into the notch, *e e*, in "wall plate," and the "tie beam" placed *in situ*, the upper part of the cog, *d*, passing into the notch on its under side.

16. **Junction of Foot of Principal Rafter with Tie**

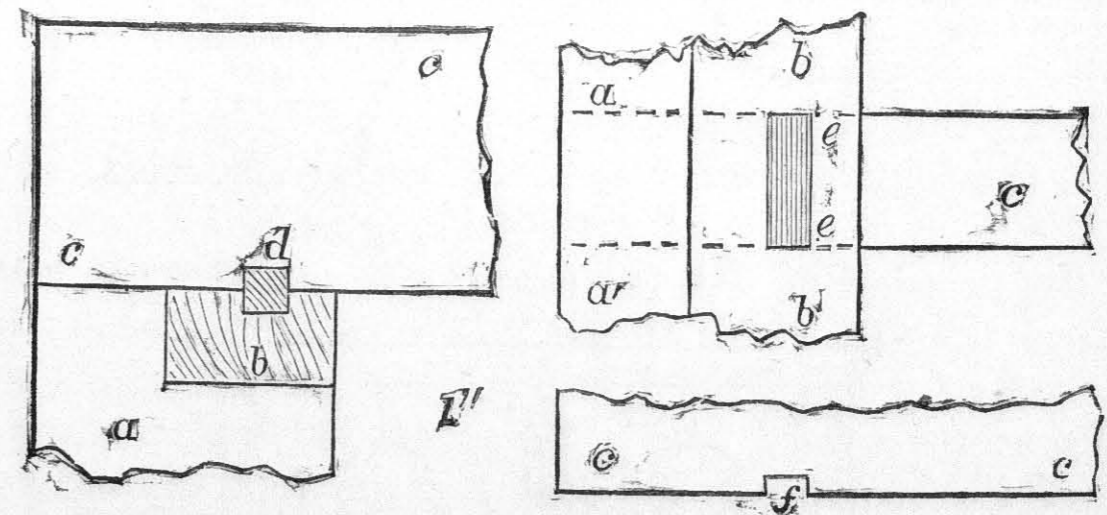

Fig. 36.

Beam.—The simplest method of forming this junction is by cutting out a notch in the upper edge of tie beam, *a a*,

fig. 37, with an angular end, as at *b c*, and sloping edge, *c d*; the end, *b c*, being at right angles to the face, *b e*, of the principal rafter, thus giving the best butting

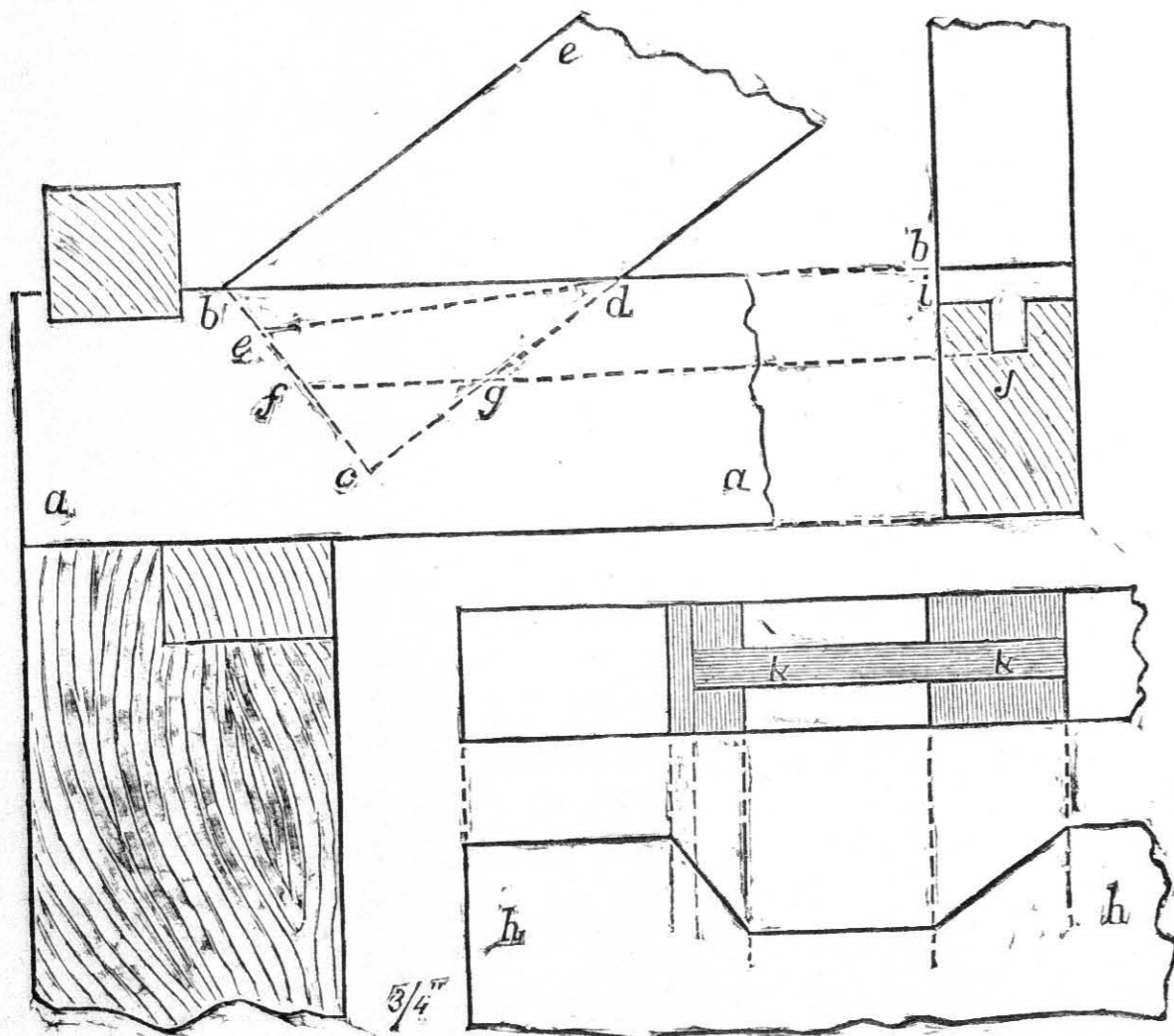

Fig. 37.

surface. But this method, cutting too deeply into the tie beam, the joint is passed in a horizontal direction, as at *f g*, the form of the part cut out being as in *h h*, which is the upper edge of the tie beam. The part from *b* to *e* is kept the full width of the thickness of tie beam; but the part *e f g d* is formed into a tenon, as at *j*, which goes into a mortise, *k k*; this last diagram being plan of upper side of tie beam, showing seat for the foot of principal rafter. Another form of joint is that indicated by the line *i d*, the part *b i* being at right angles to *b e*. Fig. 38 shows another method of forming the junction of the foot of principal rafter, *a a*, with tie beam, *b b*; *d*, the tenon;

e e, the mortise; the dotted lines give the projections of

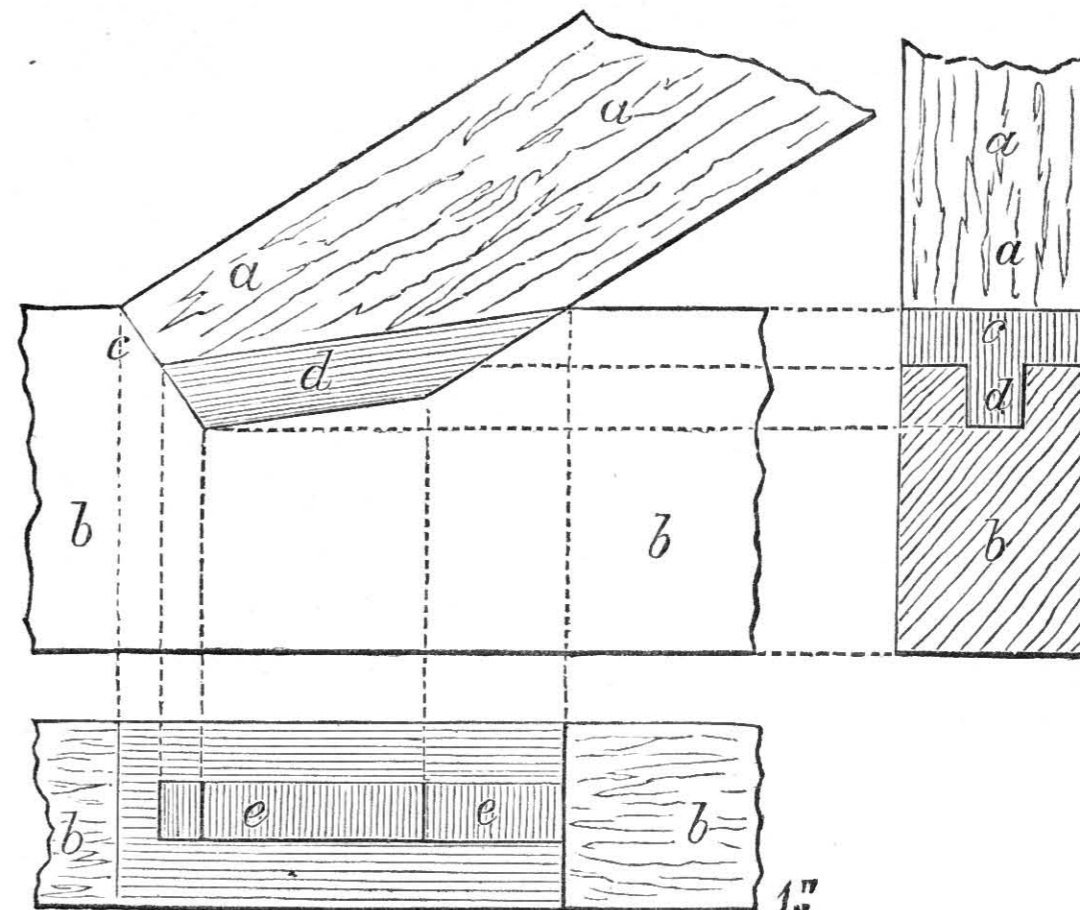

Fig. 38.

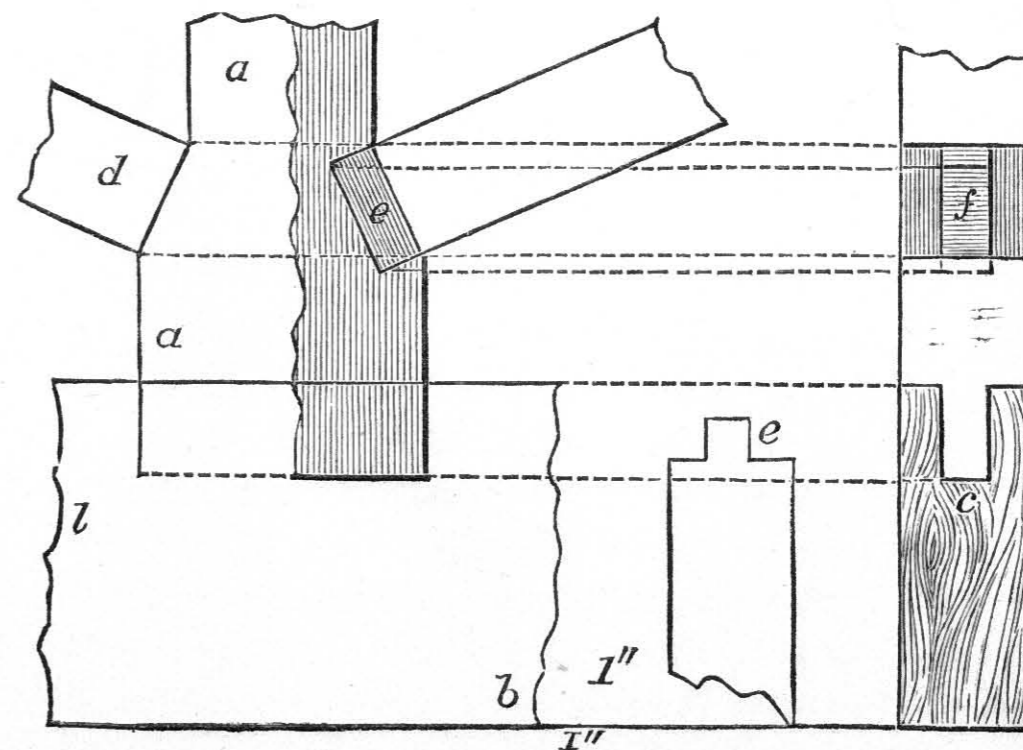

Fig. 39.

various parts, which the reader should study, to aid him in intelligently understanding the details of the joints.

17. Junction of Foot of King Post with Tie Beam.—

In fig. 39, the foot of the "king post," $a a$, is tenoned into the upper face of the "tie beam," $b b$, as at c , in the cross section to the right. The end of the "strut," d , may simply butt up against the sloping shoulder at foot of king post; but the better way is to tenon the end of the strut, as at e , the mortise being made in the face of the shoulder at f . In the diagram, half of the king post is shown in section. As the tendency of the tie beam is to fall away from the "king post" (see "Remarks on Strains in Beams" in the *Building Construction, Advanced Course*, in this series), an iron strap is used to connect the tie beam. In fig. 40, the

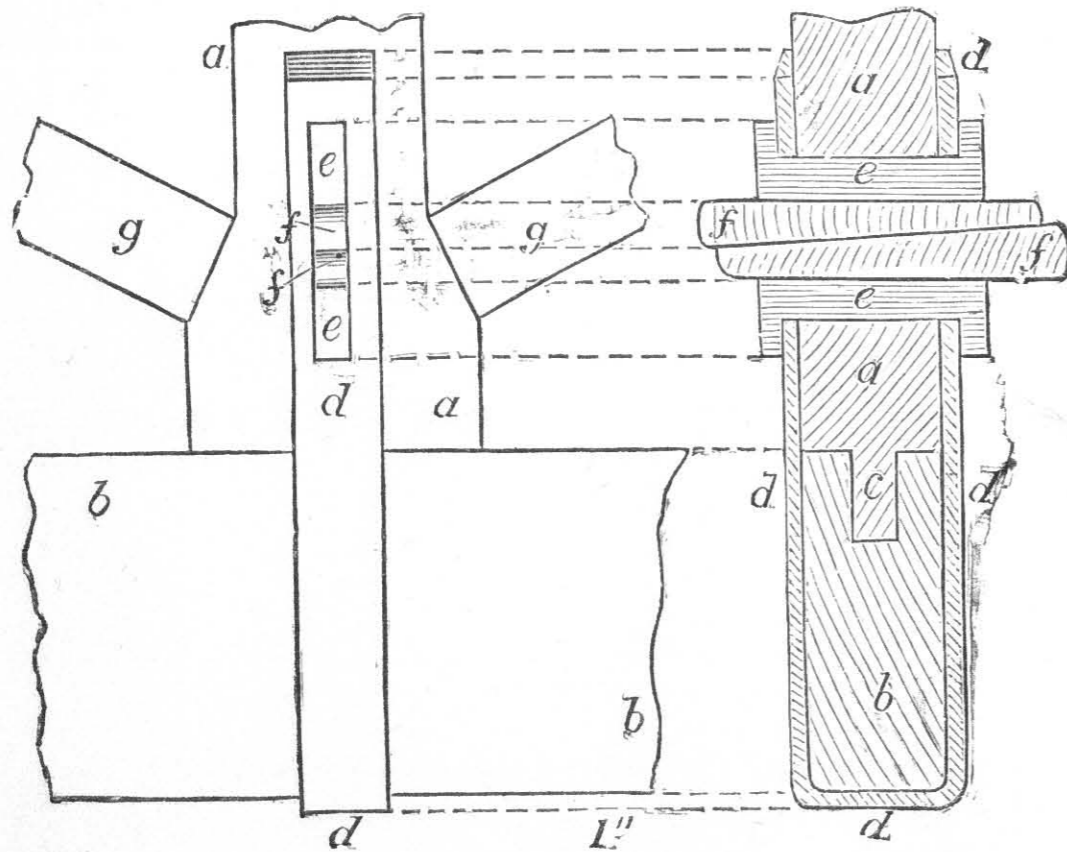

Fig. 40.

method of using a strap is illustrated— $a a$, the king post tenoned into the "tie beam," $b b$, as at c . A wrought-iron strap, $d d$, is passed round the tie beam, and secured to the king post by the iron "gibs," $e e$, and "keys," $f f$; $g g$, the struts or braces. The diagram to the right is a cross section. (See last Chapter, p. 24.)

18. Junction of Struts or Braces with Upper Ends of King and Queen Posts.—Fig. 41 illustrates two methods, —one to the right, the other to the left of the central line $a' b'$; $a a$, the king post; the sloping shoulder to receive the butting end of the strut, i , may be of the same width as the end of the strut, as $b c$; the end of i being tenoned into the shoulder, $b c$, at d . But, as this arrangement gives a wide and, in some cases, a clumsy appearance to the head of king post, the method shown to the left of the line $a' b'$ is adopted. In this there are two faces, $e f$, $f g$, to the

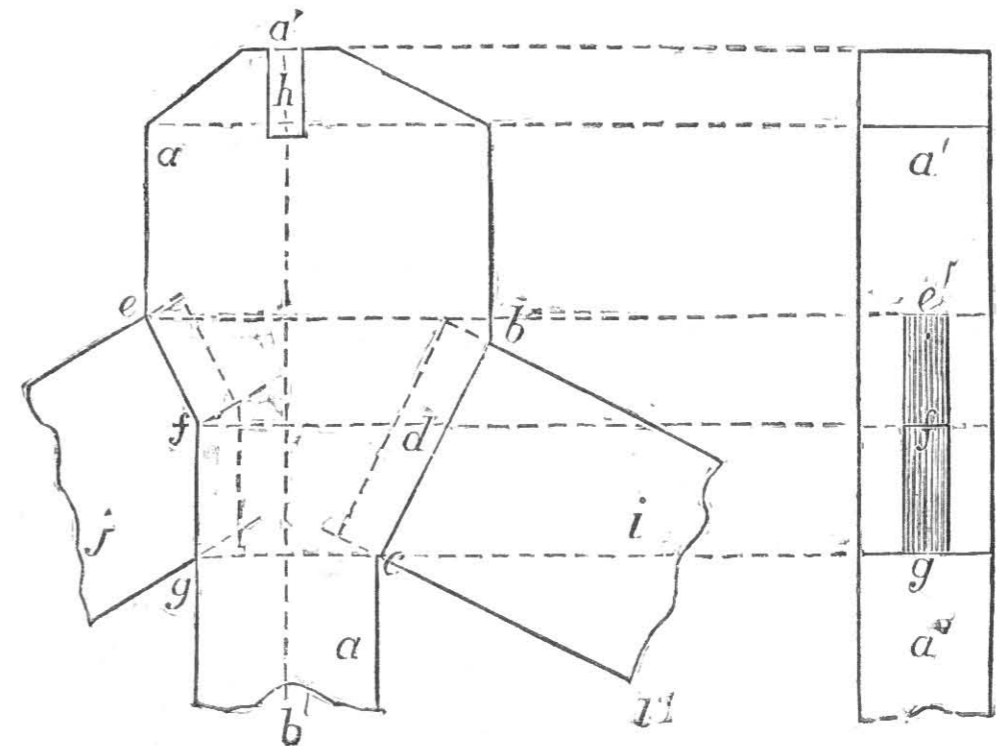

Fig. 41.

end of the strut, j ; and two faces corresponding to the tenon, $e' f' g'$, in the edge of the king post, $a' a'$. (See second view to the right.) In both cases the lines $b c$ and $e f$ are at right angles to the line of face of struts, $i j$. The "ridge pole," or ridge piece, is inserted at top of the king post, in a groove, h , cut for the purpose. In usual practice, especially necessary in the case of roof trusses for wide spans, the "struts," i and j , are kept in connection with the king post by an iron strap; for description of which see Chapter on "Lead and Iron Work."

19. Junction of Straining Beams with the Head of Queen Post—

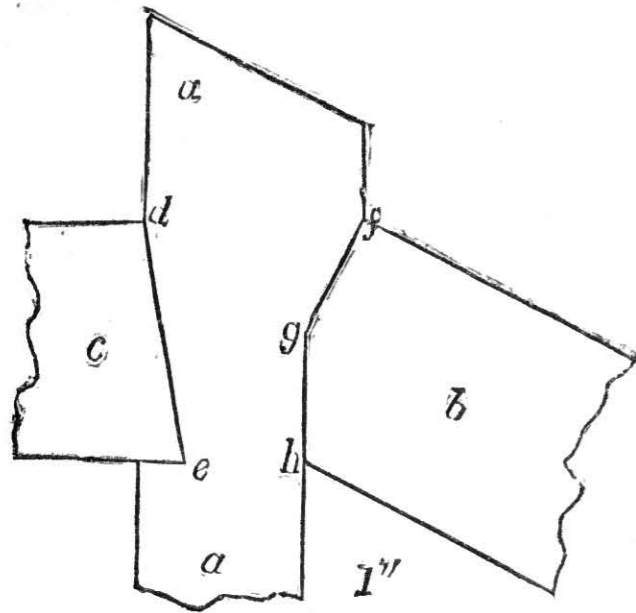

Fig. 42.

A better joint for this part is shown in fig. 43, a tenon, *a a*, being formed at the end of the straining beam, *c*, this passing into a mortise, *b b*, in edge of queen post.

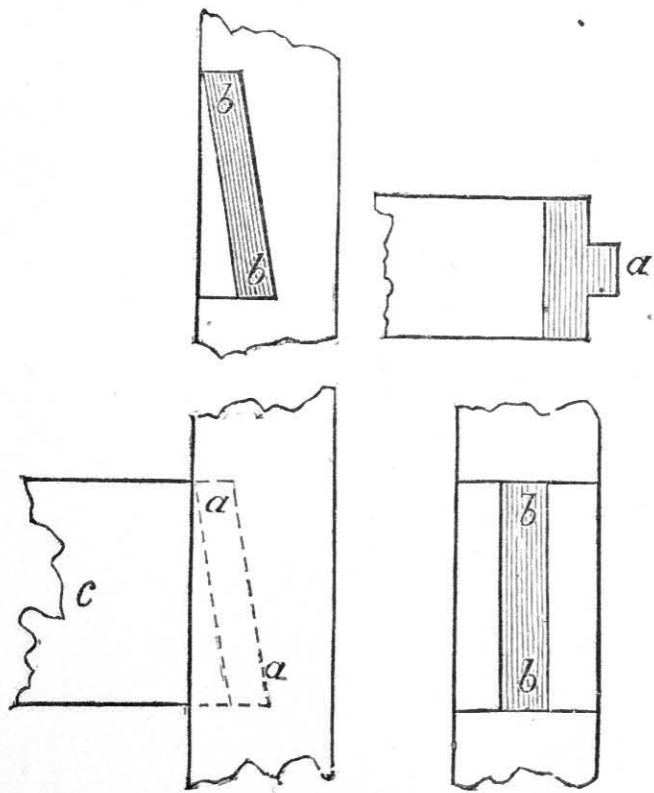

Fig. 43.

The whole are secured together by screw bolts and nuts, *i i*. The drawing in fig. 45 illustrates the junction of head of queen post corresponding to the arrangement shown in fig. 44, *a a* being the queen post made up of two pieces, *b b*, *c c*; *d d*, the "principal rafter;"

e e, the straining beam, jointed at *f g*, and secured by the screw bolts and nuts, *h h*; *i*, section of straining beam, *e e*.

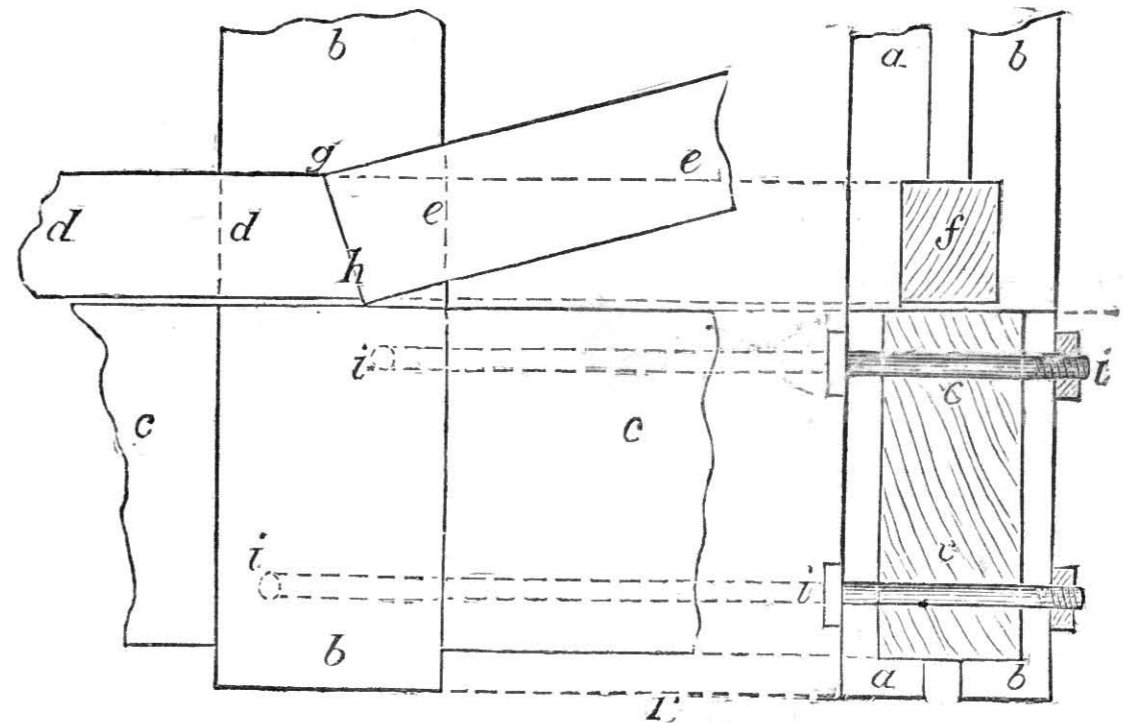

Fig. 44.

20. Junction of Purlin with Principal Rafter.—Purlins are secured to the principal rafter in a variety of ways, one of which is shown in fig. 46; in which *a a* is

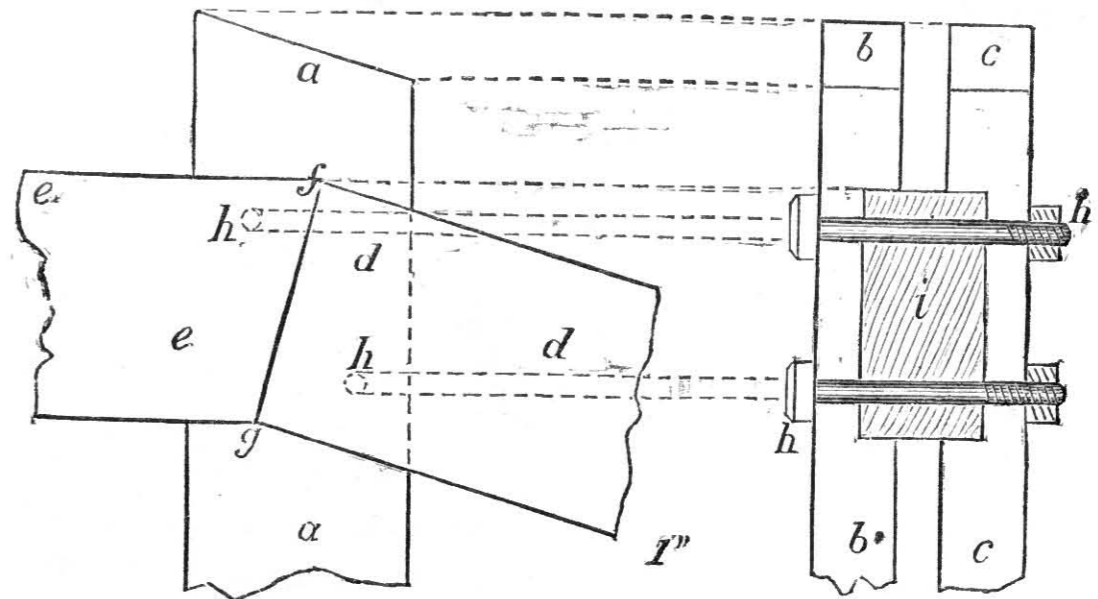

Fig. 45.

the "principal rafter;" *b*, the "purlin," notched at its lower end into edge of "principal rafter," *a a*, and at its upper end to the "common rafter," *c c*. A "blocking

piece," *d*, is notched into face of the rafter, *a a*, against which the lower face of purlin, *b*, rests. When it is deemed to have the space *e e* between the principal, *a a*,

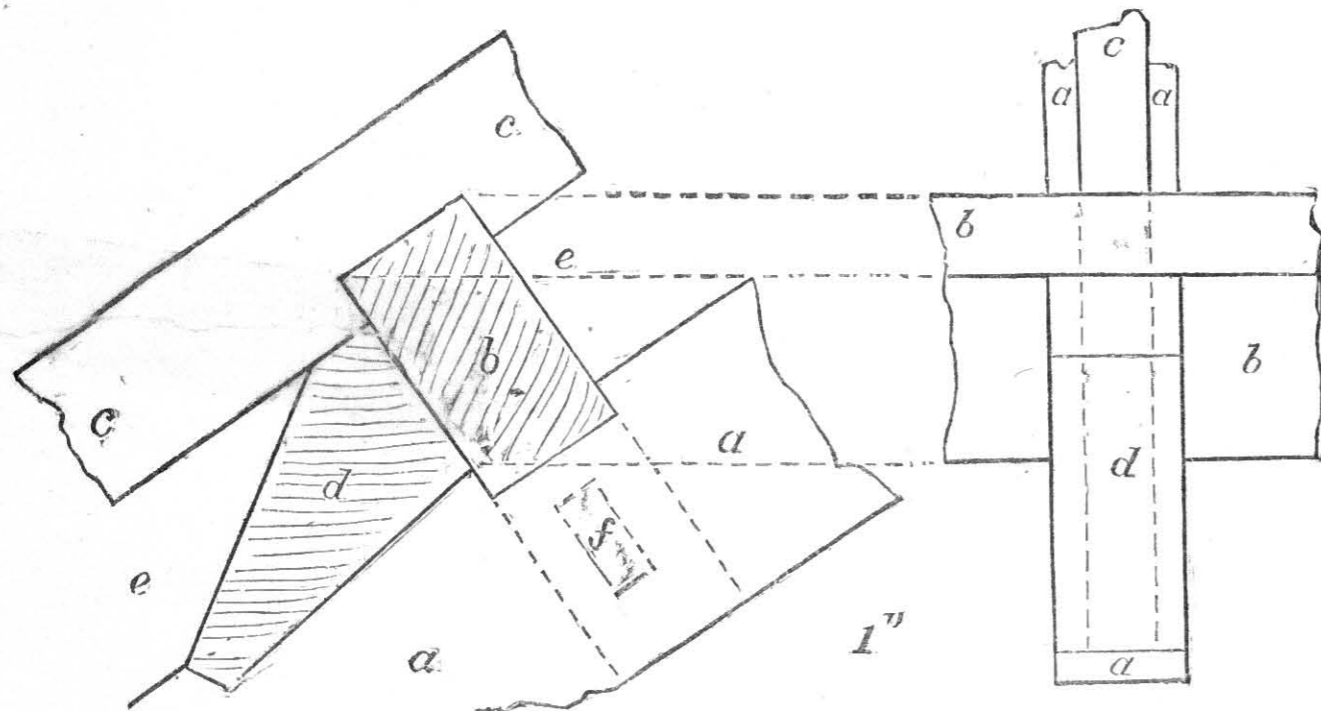

Fig. 46.

and common rafter, *c c*, done away with, in order to lessen the depth of the truss, the "purlin," *b*, is cut into short

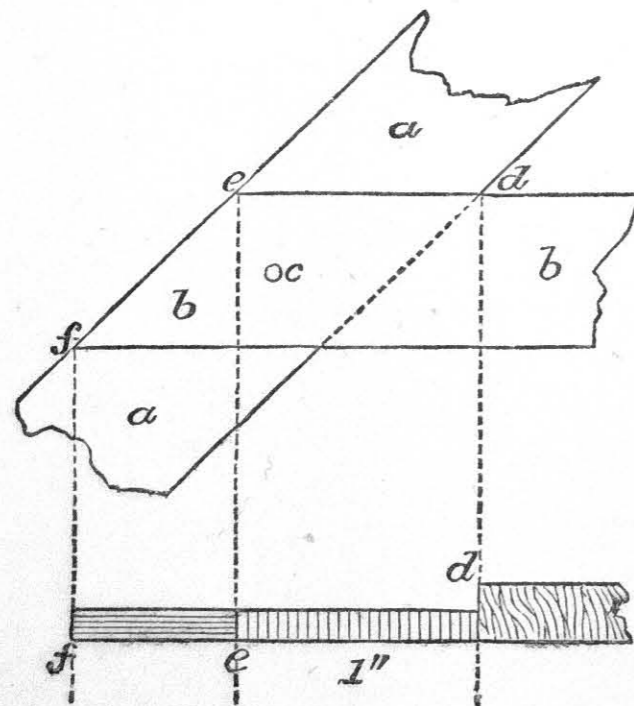

Fig. 47.

lengths, and each length tenoned at the end into mortises, as shown by the dotted lines, *f*, made in the faces of the rafter, *a a*. This method, weakening as it does the strength of the rafter, and throwing the whole strain on the purlin upon the tenon, *f*, is not to be recommended. In roofs of small span, the blocking piece, *d*, is dispensed with, and the purlin merely notched into edge of rafter, *a a*; or it may be simply laid in the edge and spiked to the rafter. In fig. 46,

the drawing to the right is a side elevation of the section to the left.

the drawing to the right is a side elevation of the section to the left.

21. Junction of a Collar Beam with Rafter—Illustrated in fig. 47, in which *a a* is the rafter; *b b*, the "collar beam;" the two being notched to each other with a half lap joint, as shown at *d e*, which is a section of the collar beam, *b b*, on edge. The notch cut in face of the rafter is equal in depth to half the thickness of the collar, *b b*, so that when the two are laid together the surface of *b b* is "flush" or even with the surface of *a a*. The two are secured together by a nail at *c*. In simple work, the collar, *b b*, is simply nailed to the face of *a a*. In fig. 48, we illustrate another form of

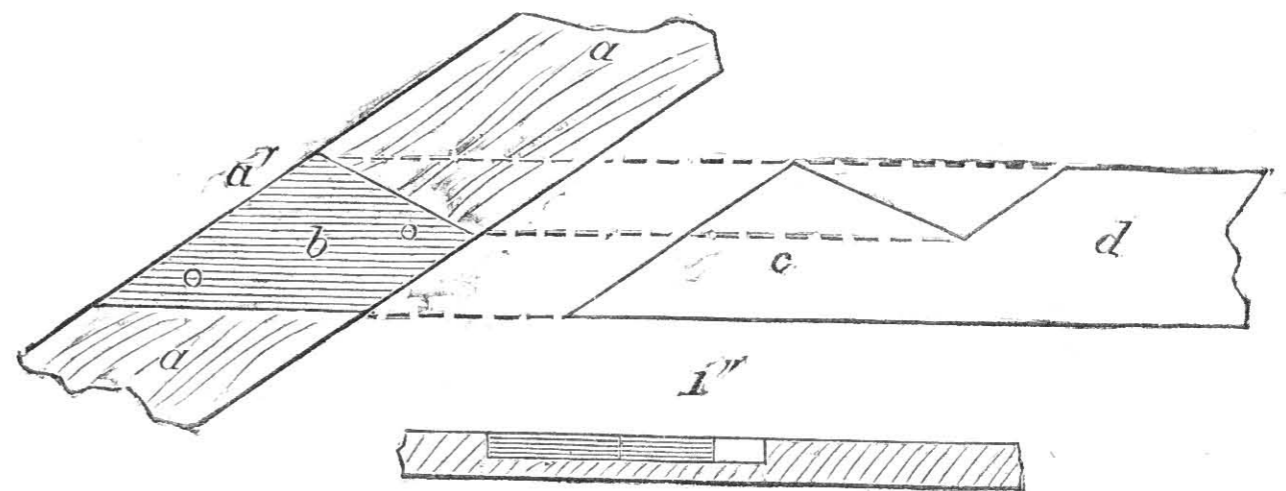

Fig. 48.

this joint, a part of the face of "rafter," *a a*, is cut out at *b*, the end of the "collar beam," *c d*, being cut to corre-

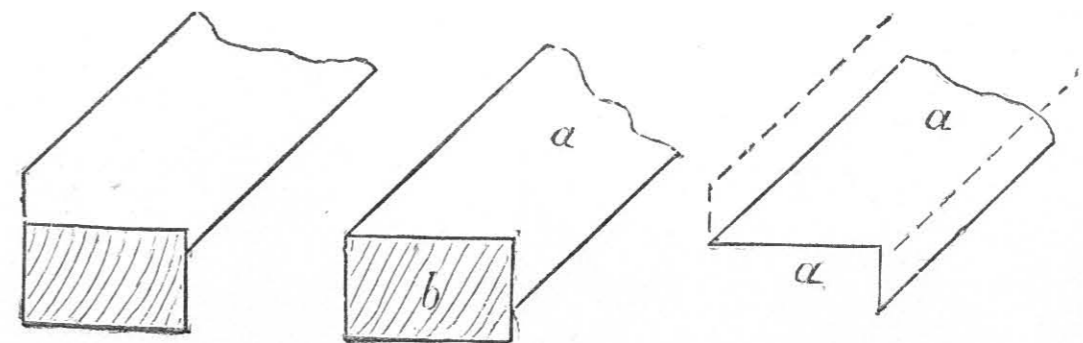

Fig. 49.

spond; the end *c* is of the thickness of the depth of the part *b* cut out in face of *a a*, so that when put together

the faces of *a a*, *c d*, will be "flush." The lower diagram

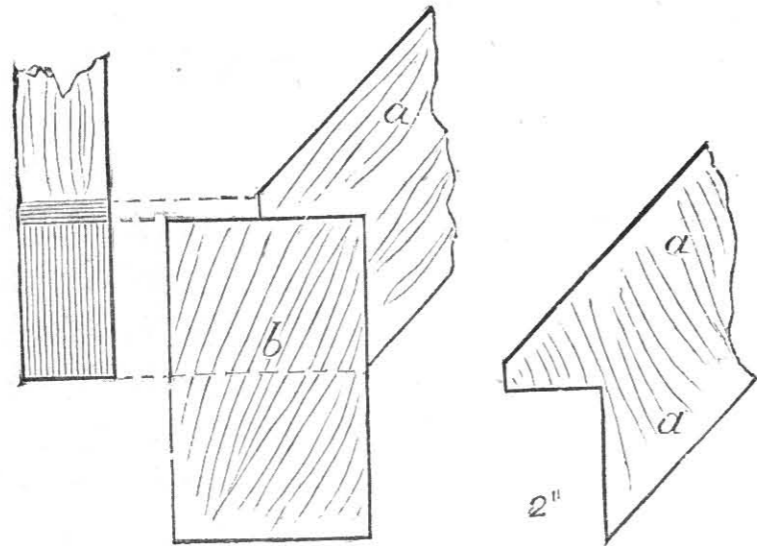

Fig. 50.

in fig. 48 is a section of the edge of *a a*, looking down

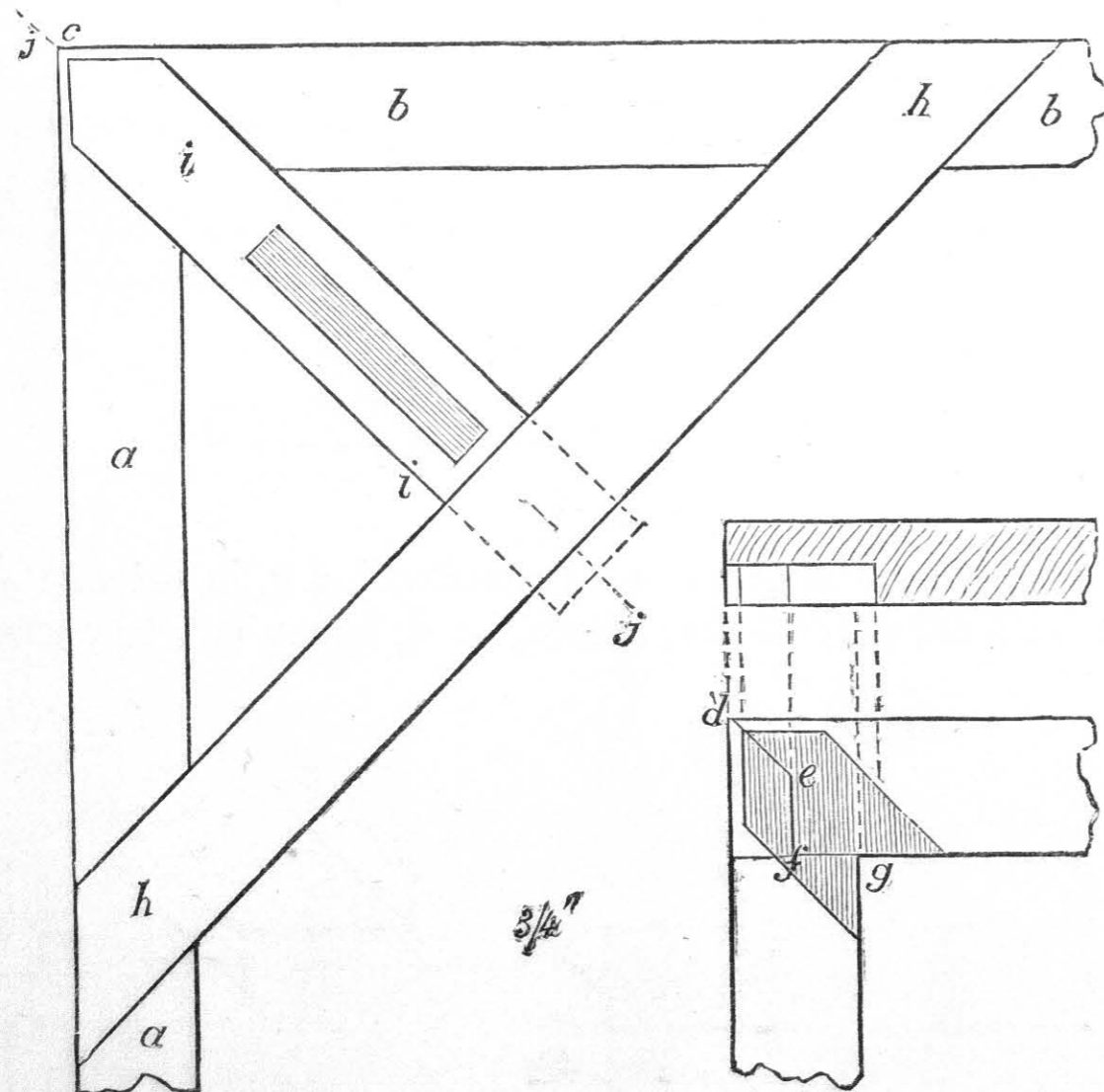

Fig. 51.

upon it from the side, *a'*, when laid horizontally. In fig. 49,

the joint known as a bird mouth joint is shown, being used where an angular timber, *a a*, as a rafter joins a "wall plate," *b b*; this is shown also in fig. 50.

22. Junction of the Foot of a Hip Rafter with Wall Plate.—In this *a b*, fig. 51, are the wall plates, joined at the corner of the wall, *c*, by the joint, as shown at *d e f g*; a piece, *h h*, is thrown across at the angle shown, joining the two wall plates with a half lap joint; this piece, *h h*, is called the "angle tie;" and in roofs of small span this receives the foot of the "hip rafter," as at *a* in fig. 52.

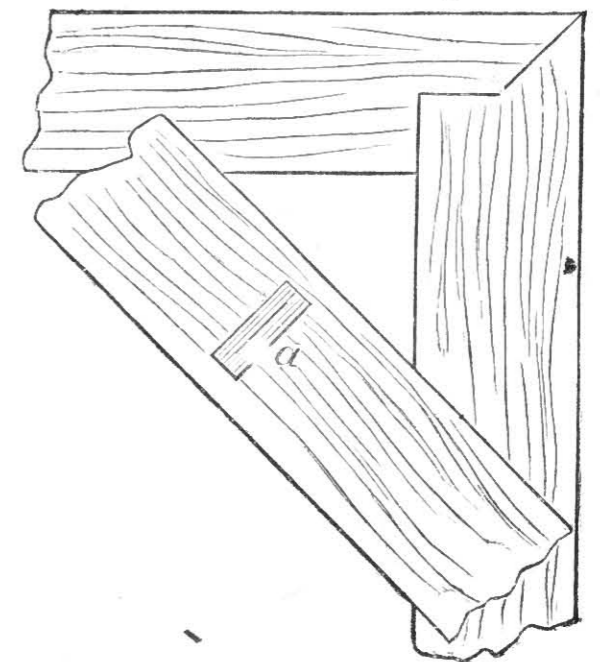

Fig 52.

But in a higher class of work, and with roofs of great span, another member is provided, as *i i* in fig. 51. This is called the dragon beam, or dragon tie, and its office is to carry the foot of the hip rafter, as *a a*, fig. 53; in this figure, *b* being the dragon beam, corresponding to *h h*, fig. 51; *c*, the "angle tie," corresponding to *i i* in fig. 51; *d* being the wall plate, *b*, in fig. 51. Fig. 53 is a side elevation and section in the line *j j*, fig. 51. The "dragon beam," *b*, fig. 53, is tenoned into the "angle tie," *c*, as shown, with a "tusk tenon;" or a tenon may be carried through the tie and pinned, as shown by the dotted lines. The end of the dragon beam near the wall plates is half lap notched, into face of wall plates, as

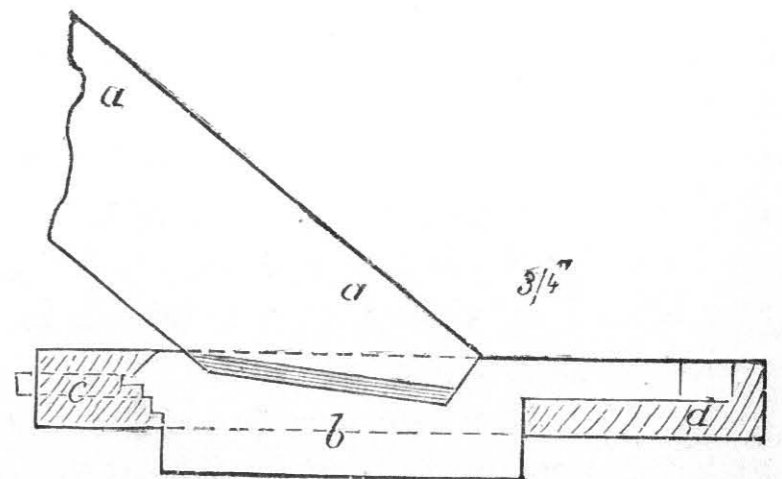

Fig. 53.

plates is half lap notched, into face of wall plates, as

shown at *d*, fig. 53, a corresponding notch being cut in the wall plates, as shown at *e f g*, fig. 51.

23. Centres and Miscellaneous Joints.—In addition to its uses in the construction of floors, roofs, and partitions, such as we have described in the preceding paragraphs, timber is used in framing structures for a wide variety of purposes, as “gates,” “scaffolding,” “bridges,” “centres,” and in the construction of houses built entirely of wood, such as “sheds,” “warehouses,” &c. To illustrate all these in the present volume would not only take up much more space than its pages can afford; but not coming within its scope, these most important structures will be found by the Reader anxious to gain a knowledge of their general features and of their special details, in the volume entitled, *The Advanced Course of Building Construction*, in the present series of technical volumes; and very full information, not coming within the scope of the volumes in this series, in the large work entitled, *The New Guide to Carpentry*, edited by the author of the present volume. We think it right, however, to give here a few examples of simple forms of “centres” or “centreings,” which are certain arrangements of timber framing, used to support the brick or stone work of arches when these are in course of construction, and are, therefore, purely temporary structures, and are taken down after the brick or stone arch has firmly settled. The taking down of the centres from beneath the brick or stone work is called **striking the arch**, and to aid this a certain arrangement is made use of, which will be presently explained. In fig. 54 a simple form of centre for a semicircular arch is shown; in this the lines *a b*, *c d*, show the side walls terminating the width of opening, *e e*, which is to be finished with a semicircular arch at top. When the walls are at the height of the line *a c*, which is the springing line of the arch, the “centreing” or “centre” is erected: The upper part of the arrangement of timbers which is to support the arch is framed in a way more or less complicated,

according to the width of the opening, *e e*, or the span of the arch. In fig. 54 this part is simple, being formed of two planks, *f g*, the outer edges of which are cut to the

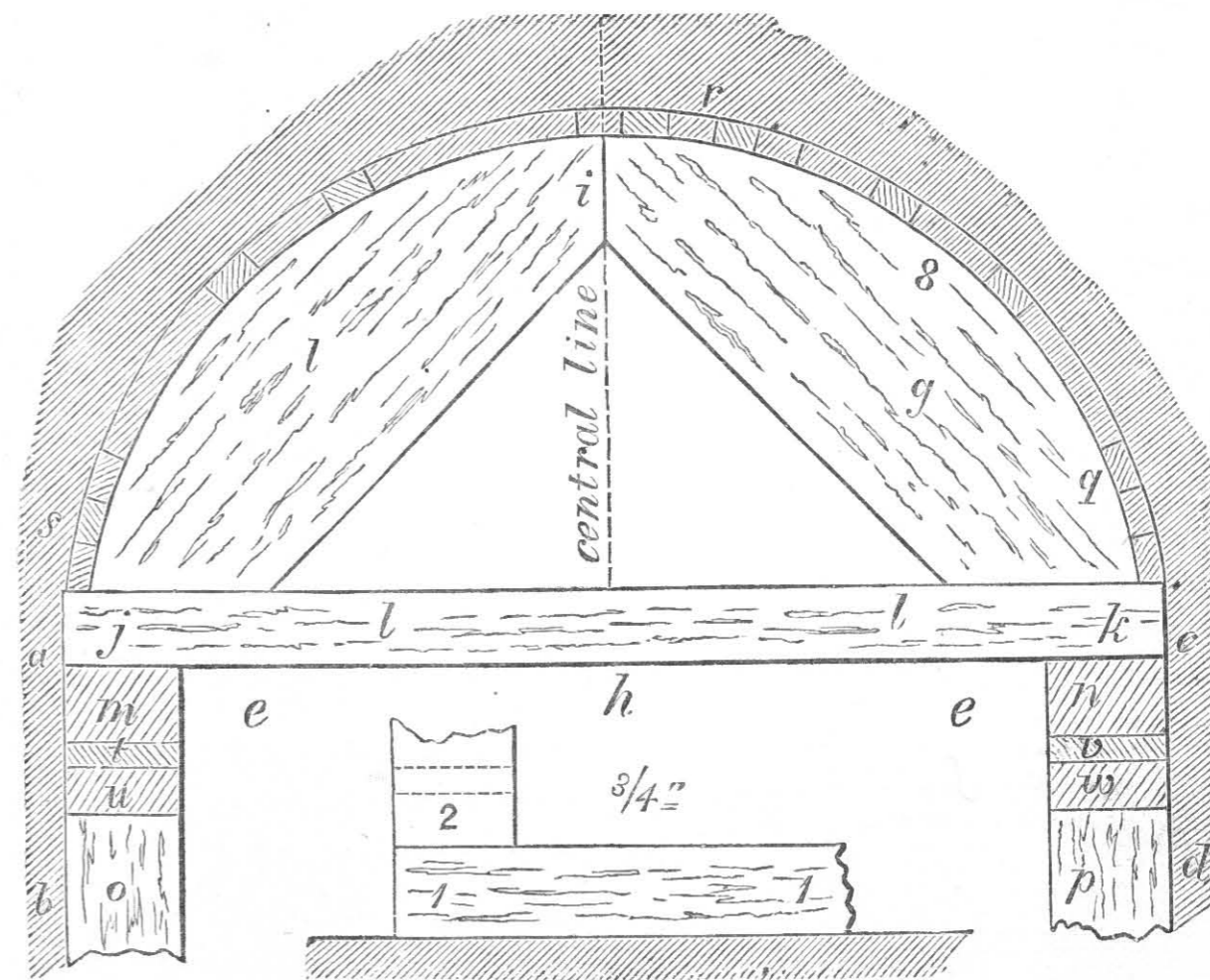

Fig. 54.

circle of the arch, this being described from the point *h* in the line *a c*. These two pieces butt at their upper termination at *i*; and are nailed at their lower ends, *j* and *k*, to a cross piece, *l l*. In some cases this cross piece is omitted, the ends *j* and *k* simply resting on the pieces *m* and *n*, which run across the walls in the direction of their thickness, and at right angles to the piece *l l*. In the arrangement shown, the pieces or “centre” proper, *f g* and *l l*, are supported by the cross pieces or cushion timbers *m* and *n*. These are again supported by the upright posts *o* and *p*, the lower ends of which rest upon the ground, in the case of arches being built on the ground floor of a building, and upon a sill in the wall in

the case of an arch being built on an upper storey. To prevent the feet of the posts penetrating the ground or soil, they rest upon a piece of timber termed a "cill" or "sill," shown at *l l* in fig. 54, *2* being the foot of posts, *p o*. The cross pieces, *m* and *n*, pass through, as above stated, the opening across the thickness of the wall, *a b*, *d c*, and are terminated at the opposite or inside face of the wall, supposing the side, as seen in drawing, to be the outside of the wall. The inner end of the cross pieces, *m* and *n*, support an arrangement of timber precisely similar to that shown in *j f*, *g k*, and *l l*. This is illustrated in fig. 55, which is a side or edge elevation of the centring and wall,—the wall, *a b*, being that lettered also as *a b* in fig. 54. In fig. 55, *c c*, *d d* indicate the parts corresponding to *j f*, *g k* in fig. 54,—*c c* being that at the outer, *d d* that at the inner face of wall; *m m*, in fig. 55, is the cross piece, *m*, in fig. 54; *o o*, the posts corresponding to *p* and *o* in fig. 54. The two pieces, *c c*, *d d*, fig. 55, support or carry cross pieces, *q r s*, fig. 54, these uniting the two sides, *c c*, *d d*, of the centre proper. These

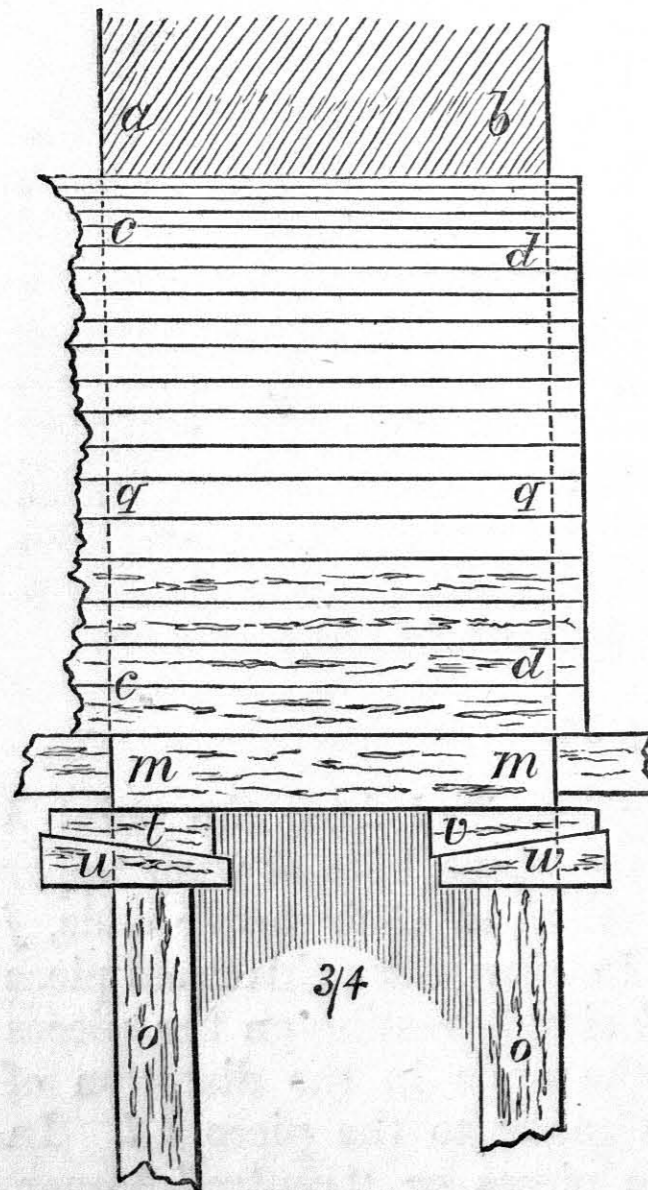

Fig. 55.

pieces are either placed close to each other, as at *r s*, forming a platform or floor, so to say, on which the brick or stone forming the arch is laid in course of building; or the pieces may be laid each being separated from its

neighbour by a short space, as shown at *q q*, in fig. 54. The interspaces may be less than the breadth of a brick, in small arches; or in the case of arches of wider span, and where stone is used, may be much wider. These cross pieces, *q r s*, fig. 54, are termed **bolster pieces**. The arrangement for "striking the centres" is shown at *t u*, *v w*, in figs. 54 and 55. In this double wedges are employed, the large end of one of the wedges, as *t*, in fig. 55, being placed at the small end of the other wedge, as *w*. When the building of the arch is completed, the centre is not removed at once, but the whole allowed to remain for a length of time, longer or shorter according to circumstances. As the brickwork or stonework of the arch gradually settles, the wedges are gradually driven out or loosed, thus allowing the cross pieces, *m* and *n*, and the upper part of the centre to drop gradually. When the settlement is completed, the wedges are driven clear out, and the centring wholly removed. In some cases the wedges are used at the lower part of the posts.

In describing the various forms of floors, partitions, and roofs, in the preceding part of this chapter we have followed up each division with illustrations and descriptions of the "joints" used in framing the component parts of the various structures. In these we have comprised examples of nearly every class of joints used in framing timbers together, whether these be employed in floors, partitions, or in roofs, or in other structures, as bridges, &c. As supplementary to these, and as also affording examples of forms of joints not there described, we add a few more illustrations before concluding this chapter.

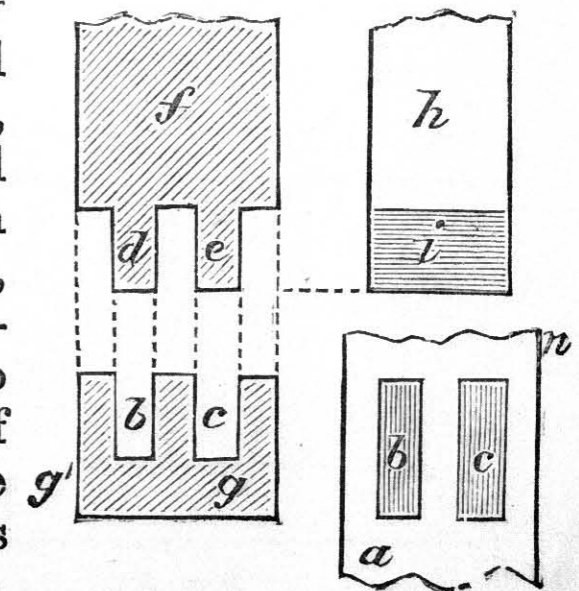

Fig. 56.

In fig. 56 a double mortise and tenon joint is illustrated (for a single joint of this kind, see

fig. 19), being that most generally employed. In fig. 56 *a a* represents part of the horizontal timber in which the two mortise holes, *b c*, are cut to receive the two tenons, *d e*, cut at the end of the vertical piece, *f*, which is to be joined to the piece *a a*. A cross section of *a a* is shown at *g g*; and a side elevation of the foot of *f* at *h*; *i* being one of the tenons. In joining two pieces in the direction of their length which are to stand vertically, as where a long post is to be made out of two short ones, various modifications of the mortise and tenon joints are used. Fig. 57 illustrates one of these; in this *a a* is the upper, *b b*, the lower post. In the cross section of the lower post, *a a*, shown at *c c*, a mortise is cut, formed in two parts, one, *d*, at right angles to the other, *d'*; in the elevation *e* is the tenon in the end of *a a*, which goes into the mortise, *d'*. The joint is sometimes formed as in the lower cross section of *b b*, as at *f f*, the mortise in this case forming a cross of which *g h i* and *j* are the arms. The tenons in one end of the piece, *a a*, are made to correspond to these; and in plan, the end of *d a* is precisely similar to *f f*, the solid part of the tenons being the same as the part indicated in horizontal shading; the parts cut into at the corners of the tenoned foot of *a a* being

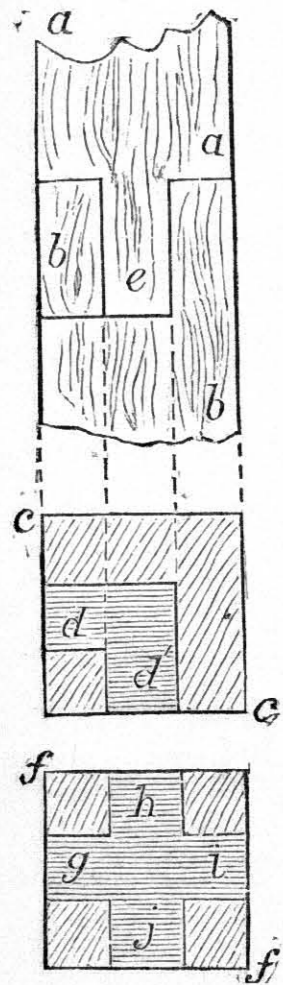

Fig. 57.

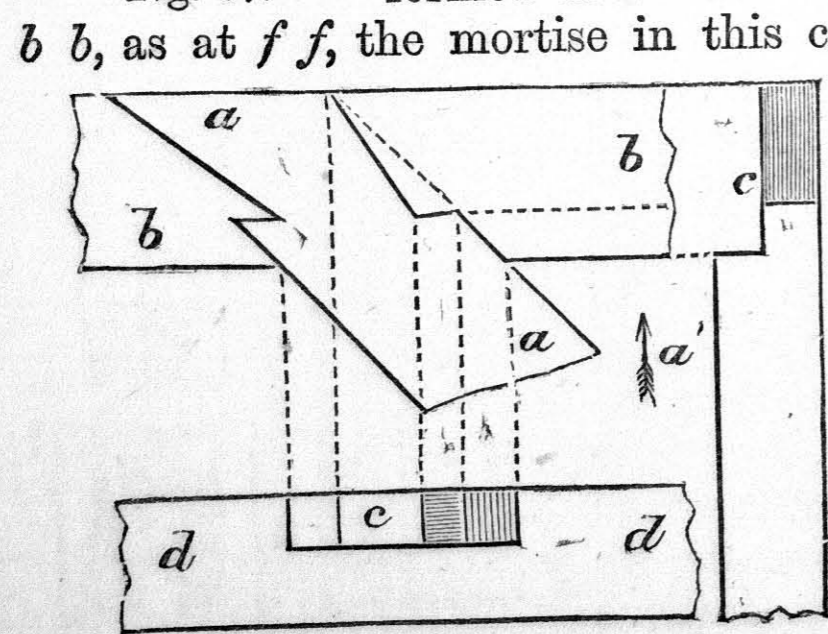

Fig. 58.

same as the part indicated in horizontal shading; the parts cut into at the corners of the tenoned foot of *a a* being

represented by the parts indicated in *f f* by cross line shading. In fig. 58 a form of joint is illustrated, used

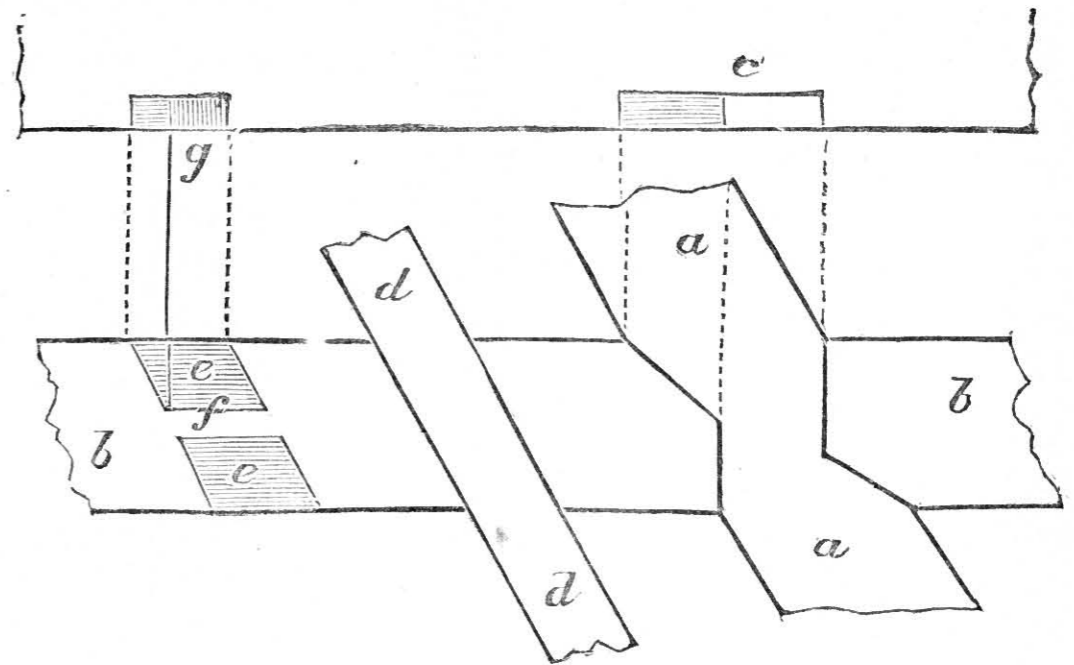

Fig. 59.

in joining two horizontal timbers, one of which, as *a a*, joins the other, as *b b*, at an angle. The pieces are half

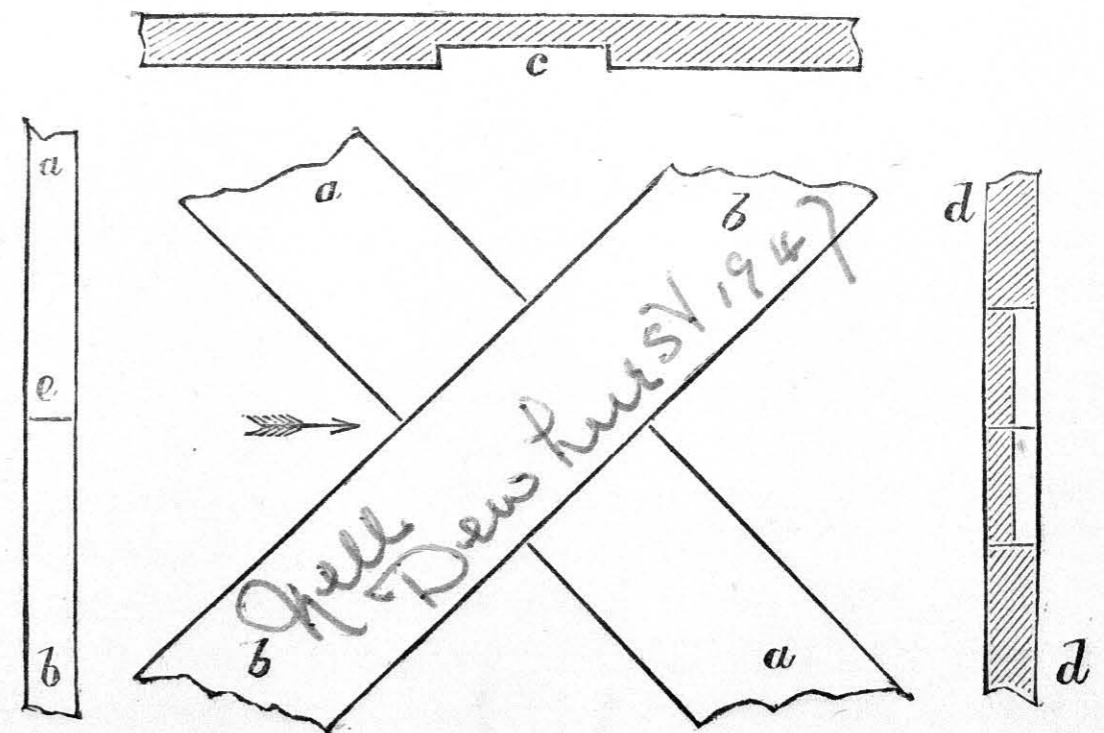

Fig. 60.

lapped, so that the surface of *a a* is "flush" with that of *b b*, as at *c* and *d d*; *c* being side elevation

of end of *a a*, *d d* being that of piece *b b*, looking in the direction of arrow, *a'*. In this construction the head of the piece *a a* terminates in a line with the outside line of the piece *b b*. In fig. 59 is illustrated a joint, in which the piece *a a* crosses another piece *b b*, and is passed on at *a* to cross another piece parallel to *b b*, or to terminate with a bearing in a wall; *c* is the side elevation of the piece *b b*. Another form is shown at *d d* in same figure, this being let into a notch, *e e*, cut in the face of *b b*, with a rib or cog, *f*, passing across it; this rib passing into a notch cut in the lower face of *d d*. *g* is side elevation, showing notch, *e e*. Fig. 60 shows two pieces crossing at an angle; one of these, as *a a*, may simply be nailed on to the surface of the other piece *b b*;

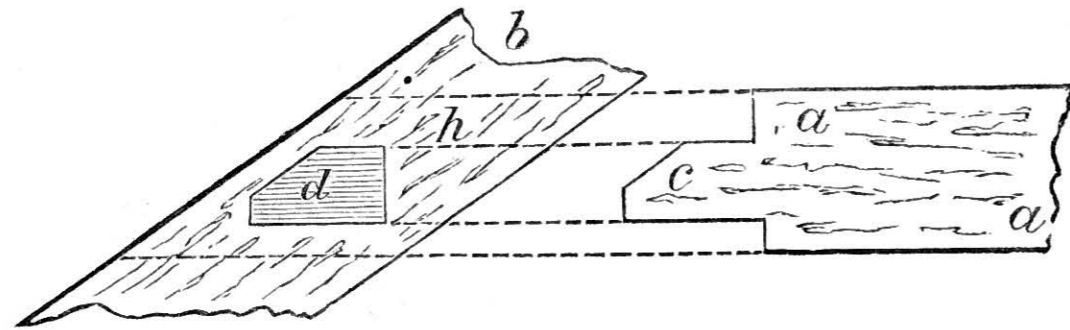

Fig. 61.

but to make a flush joint, they should be notched together half lap fashion, as at *c c*, *d d*; *c* being the edge view of one of the pieces, *d d*, or vertical section at the point of meeting of the two pieces; *e e* being an edge view of the two, looking in the direction of the arrow. Fig. 61 illustrates a joint for a hori-



Fig. 62.

zontal piece, *a a*, joining a piece at an angle, *b b*; the end, *c*, of *a a* is cut with a projecting part, as at *e*, in edge view of piece, *e f*, fig. 62; this goes into the part *d* cut out in the face of *b b*; the part *h*, within dotted lines, receives the corner of *a a*, and a part, *g*, is cut out in the face of *e f*, fig. 62.

CHAPTER III.

TIMBER CONSTRUCTION, AS EXEMPLIFIED IN DOORS,
WINDOWS, AND INTERNAL FITTINGS OF HOUSES.

24. Joiners' Work.—While the work of the carpenter concerns itself with the designing and putting together of the various members constituting what is called **framework**, as roofs, floors, and the like, and deals with pieces of timber of considerable size and weight, the work of the joiner concerns itself with the designing and putting together of pieces of timber, of which the dimensions are small, and weight but trifling. In large framework, the goodness of the work depends upon the accuracy with which the various members constituting the framing are placed in relation to each other, so as to distribute the pressure to which they are subjected in such a way as to obtain the maximum of strength to meet this pressure with the minimum of size and weight of the various parts. The joints and junctions of these parts, although of consequence, do not form the principal feature of heavy framework; whereas, in joinery, the goodness of the work depends almost entirely upon the accuracy with which the joining together of the various parts is performed,—the pieces themselves, as a rule, having comparatively little weight to carry, or small pressure to resist. Joiners' work, in the case of domestic structures, is chiefly connected with the construction of doors and windows, and the various parts of internal fittings made of wood; as partition and other linings, doors, skirting boards, cornices, &c. As the various minor details, such as joints, mouldings, are nearly all to be met

with in doors and windows, we shall proceed to describe the construction of doors, then of windows, and thereafter describe the joints used in putting the parts together, and the mouldings and ornamental parts by which these are enriched or decorated.

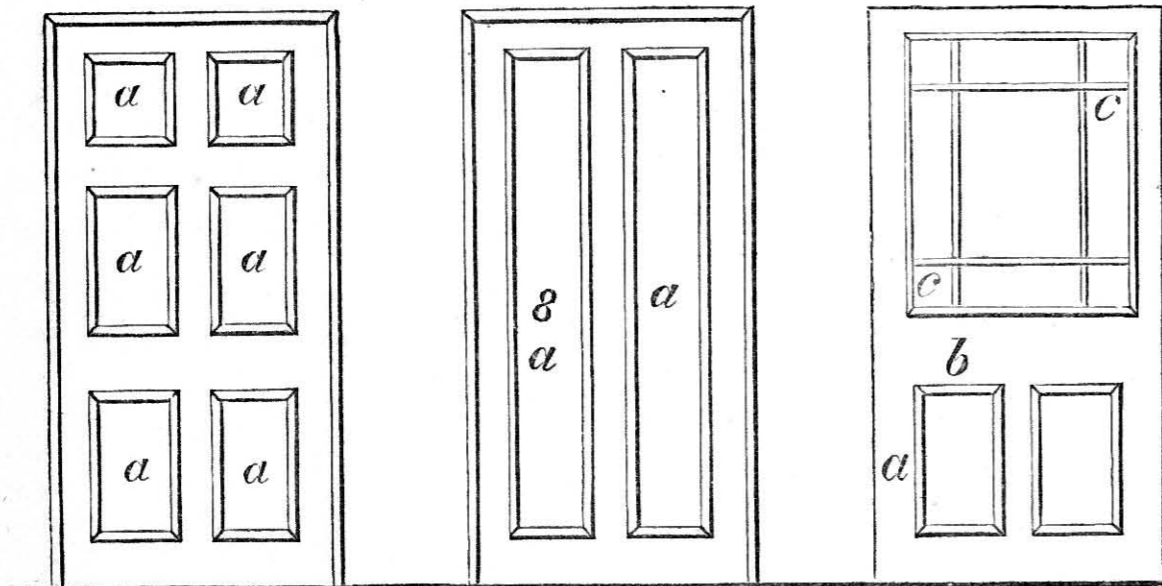

Fig. 63.

Fig. 64.

Fig. 65.

25. Doors are of various kinds, and may be divided into two classes—first, those in which “panels” do not; and,

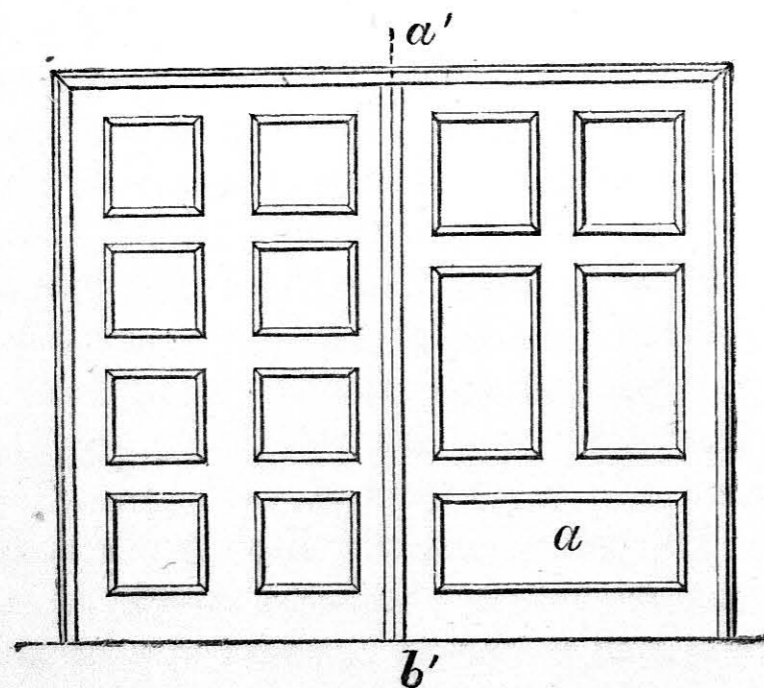

Fig. 66.

second, those in which “panels” form a part of the design. Of doors belonging to the first class, or non-

panelled kind, the most simple is what is called a “ledged;” the next in order is a “ledged and braced;” the third, “ledged and framed;” and the fourth, the “ledged, framed, and braced” door. Of the second class, or panelled, the doors are classed according to the number of the panels in each, as “four-panelled,” “six” (fig. 63), and “eight-panelled” (fig. 66). A “casement or sash door” (fig. 65) has its upper part provided with a window or glass sheets as *c c*, its lower part being panelled as *b b*. Fig. 64 is a two-panelled or front door. A “folding door” (fig. 66) is made into two parts, opening from the centre, and is used between two rooms. The drawing illustrates two methods of panelling this kind of door—half of the design being on each side of the centre line *a b*.

Ledged Door.—In Plate XII. will be found illustrations of the various forms of doors of which we have now given general descriptions. In fig. 1 is inside elevation; fig. 2, vertical section through centre of door; and in fig. 3, plan of a *ledged door*. In this *a a* are the boards forming the face of the door; these are either laid—in the simplest of work—edge to edge, or are tongued and grooved, or rebated (see “*Joints used in Joiners’ Work*”); *b b*, the ledges to which the boards are nailed. Fig. 3 is a sectional plan on the line in *b* in fig. 1.

Ledged and Braced Door.—In fig. 4, Plate XII., we give inside elevation; in fig. 5, sectional plan through line *c' d'* in fig. 4; and in fig. 6, vertical section of a “ledged and braced door.” In this the door is made up, as in fig. 1, of boards, *a a*, and ledges, *b b*; these being strengthened by the additional members, the braces, *c c*.

Framed and Ledged Door.—In fig. 7, plate XII., we give inside elevation of a “framed and ledged” door. In this the boards, *a a*, are surrounded by a frame of two side pieces, *b b*, and top and bottom pieces, *c* and *d*; the ledges, *e, e*, and *d*, are tenoned into the side pieces, as shown at fig. 10, and the boards *a a* are secured to the ledges, the one outside surface being flush with the outside of the

ledges and frame. Fig. 8 is a sectional plan; and fig. 9 a vertical section on line *ef* in fig. 8.

Ledged, Framed, and Braced Door.—In fig. 11 we give elevation of outside; and in fig. 13, elevation of inside, of a ledged framed and braced door; fig. 12 being plan; fig. 14, being sectional plan through line *ij* in fig. 13; and fig. 15, vertical section on line *gh*, in fig. 13.

Framed and Panelled Door.—In fig. 16, plate XII., we give elevation; in fig. 17, sectional plan; and 18, vertical section on line *kl*, fig. 16. The frame surrounding the panels is made up of two vertical pieces, *aa*, *bb*, these being called the “styles.” The style to which the hinges are fixed is called the “hanging style;” the other and opposite, sometimes the “lock style,” the lock being secured to it. The top cross piece, *cc*, is called the “top rail,” the lowest cross piece, *dd*, the “bottom rail;” the centre cross piece, *ee*, the “lock rail;” the vertical pieces, *ff*, parallel to the styles, *aa*, *bb*, and placed centrally between them, are called the “muntins;” the panels, *gggg*, are tongued and grooved into the styles and rails as shown in fig. 17. In fig. 19, plate XII., we give details, one-fourth full size of the ledge, *ee*, of the door in fig. 7; and in fig. 20, section and elevation of part of the boards, *aa*, of same door, showing how they are joined. In fig. 21, plate XII., we give a section showing part of panel, *g*, and of style, *b*, of door in fig. 16. The scale to which the elevations are drawn in plate XII. is given in plate XIII.

Interior or Dining Room Door.—In plate XIII. we give drawing of this, having moulded panels and architrave. Fig. 1 is elevation of side of door towards the room; fig. 2, that of door towards the passage; fig. 3 is vertical section; fig. 4, plan; fig. 5 is a section of the architrave, *aa*, *aa*, figs. 1 and 4; fig. 6, a section of part of fig. 1, on the line *a'b'*. In fig. 6, *a* is the style *b'*, fig. 1; *c*, part of the panel and its moulding on the back “bead and butt,” as shown in elevation at *aa*, *bb*, fig. 2; the moulding, *d'*, fig. 6, to the front of the panel is “bead and flush;” *d*, part of the panel and moulding towards the

muntin, *c*, fig. 1; *e* being part section of this in fig. 6. Part of the door lining is shown at *f*, *g*, being the “rebate,” or part cut out, into which the style, *a*, fits. Fig. 7 is section of the “lining” with the end, *a*, moulded in place of being plain, as at *f*, in fig. 6. The corner, *b*, is finished with a “double quirk,” as at *b* in fig. 4. In same figure, *e* is the style corresponding to *f* in fig. 1, plate XIII.; *d*, the panel; *c*, the muntin; *e*, the panel; and *e'*, the style, *f*, in fig. 1; *f f*, fig. 4, the door lining, section of which is given in fig. 7; *gg*, the grounds for architraves; *aa*, being section in fig. 5; *hh*, the brick wall; *ii*, the plastering. In fig. 3, plate XIII., *a*, is top rail; *b*, lock rail; and *c*, bottom rail of door; *de*, panels; *ff*, skirting boards; *g g*, door linings with double quirk at *h*; *i*, line of architrave.

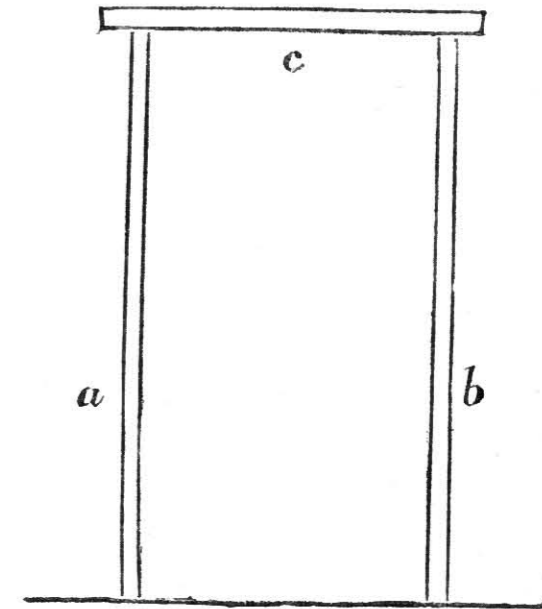

Fig. 67.

Casings of Doors.—Doors are hinged or “hung” to door casings, which line three sides of the door opening in the wall, as in fig. 67; the pieces enclosing the side walls being termed the

“jambs;” as *ab*; the cross piece, *c*, the “head.” The jambs, *ab*, are secured to wood bricks inserted in and built into the wall, as at *d*; these wood bricks are the same dimensions as ordinary bricks. (See *Building Construction, Elementary Series, Part I, “Work in Brick and Stone.”* The jambs are “rebated” (see description of “Joints,” in a succeeding paragraph) on one side, as at *a* in fig. 68, to receive the door

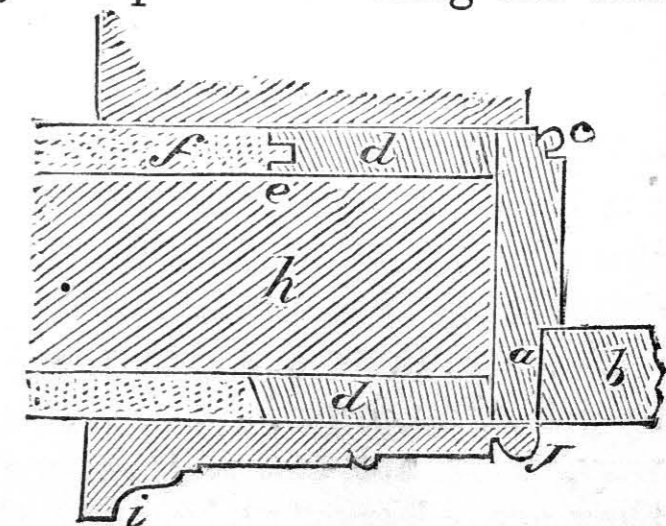

Fig. 68.

“rebated” (see description of “Joints,” in a succeeding paragraph) on one side, as at *a* in fig. 68, to receive the door

styles, part of one of which is shown at *b*. In place of having the other end of the jamb square, it may be moulded, as at *c*, with a "double quirk bead." The door casing is surrounded on three sides, in finished work, with what may be called a frame, made of wood, ornamented more or less completely with mouldings, and designated an **architrave**. This, as seen in the elevation in Plate XII., extends up the sides and across the head of the door opening. The side architraves are called "jamb architraves;" the cross or head, the "transverse" or "transverse" architrave. The architrave is placed with relation to the door opening, that the small end, as *j* in fig. 68, is always next the opening. The architraves are secured to pieces of timber called "grounds," which are again secured to the wall by wood bricks, as *d d*, fig. 68. The edges of these are generally ploughed or grooved, as at *e e*, fig. 68, to afford a "key" or "hold" to the plaster, *f*; or the edge of the ground may simply be splayed or bevelled off, as at *g* in fig. 68. In this figure, *h* is the brick or stone wall; *i*, the architrave. Both sides of the opening in wall may be provided with architraves, or one only, as that towards the room. The other may be left plain, and finished up in the door jamb with the plastering only. Where no architrave is provided in the door opening, the edge of the jamb lining is usually rounded off with a quirk bead. When the opening for the door is made in a partition, the posts of the partition (see Chapter Second, "Partition") bounding the opening are called the "jamb posts," and to these the door lining is secured.

26. The Panels of Doors, *a*, fig. 65, are usually of greater length than breadth; if of the same dimensions every way, they are called "square panels," as *a*, fig. 63; if they are of greater breadth than height, as when they stretch across from the hanging to the lock style, they are termed "lying panels," as *a* in fig. 66. The panels, as will be seen from Plate XII., are fixed to the styles by their edges being passed into grooves made in the styles.

As a general rule, the thickness of the groove is one-third of the thickness of the framing or style. When the panel is of this thickness, as in fig. 69, a recess, as *a b c d*,

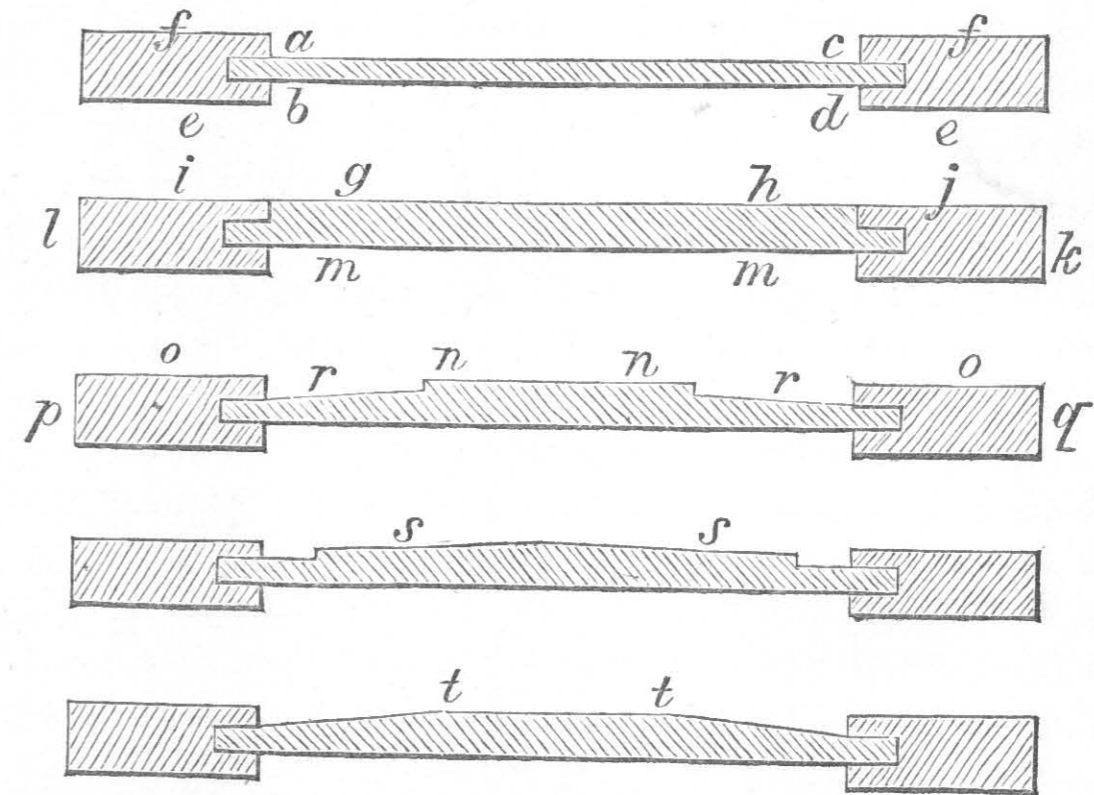

Fig. 69.

being formed on both sides of the panel between this surface and the surface, *e e f f*, of the style, it is termed a "square panel." This panel being square, both back, *b d*, and front, *a c*, the surfaces, it will be seen, do not come beyond the line of the groove—that is, the panel faces and groove sides are all in one line. When one surface of the panel, as *g h*, is flush with the surface, *i j*, of the style, *k l*, it is called a "flush panel," the back, *m m*, being "square." When the panel has its central part raised, as at *n n*, the surface being flush with the surface, *o o*, of the styles, *p q*, it is called a "raised panel;" in this the margins or sides slope off to the groove, as at *r r*. Other forms of "raised" panel are shown at *s s* and *t t*. These are all "square" at the back, but they may be made "flush," as at *g h*. When the centre of a "raised panel," as *n n*, fig. 69, is separated from the "margin," *r r*, by a moulding, as at *a a*, in fig.

70, the panel is termed a "moulded raised panel;" *b b* is part of the "margin" in each case; *c c*, part of the raised centre. In fig 70, other methods of forming the margin of a panel are shown at *d* and *e*.

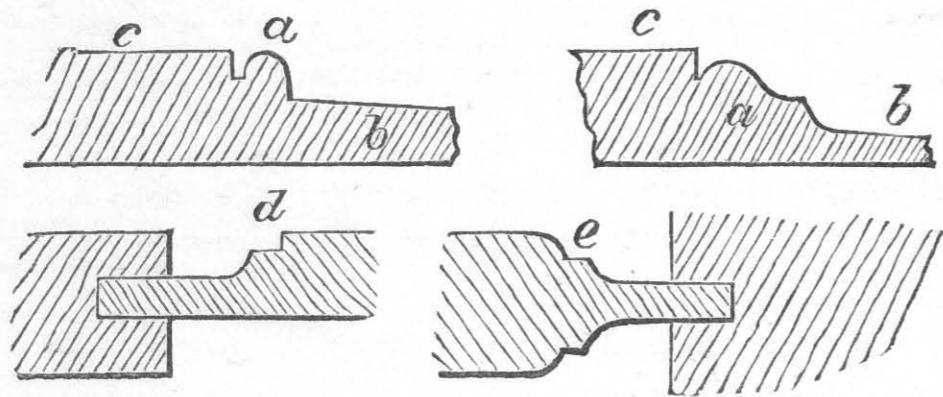

Fig. 70.

Panels are generally separated from the styles by mouldings more or less elaborate. When the panel is "flush," as at *g h* in fig. 69, the moulding is formed on the two longest sides only

of the panel itself, the mouldings being terminated at the rail lines at top and bottom, the moulding being formed with the grain of the wood. This is illustrated in fig. 71, in which *a a* is part of the style; *b b*, part of the panel; *c*, the moulding formed on the edge. The upper part of the diagram is the lower part in elevation—*d d* being part of the "rail;" *e e*, of the style; *f f*, of panel; *g*, of moulding.

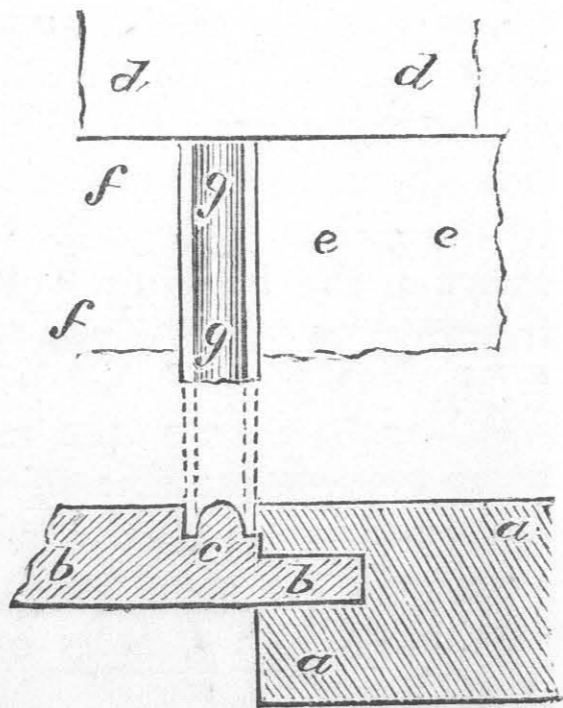

Fig. 71.

This arrangement is known as "bead and butt panel," or a "bead-but panel." When the moulding is carried round, the panel being at top and bottom, as well as at the sides; and when the moulding is formed on the under edges of the styles and rails, being "mitred" at the corners, the arrangement is known as a "bead and flush panel," or "bead-flush panel." This is illustrated

in fig. 72, where *a* is part of the panel; *b b*, part of the style or rail; *c c*, the moulding on its edge. The upper part of the diagram shows the elevation, *d* being part of the style; *e*, part of the rail; the moulding at the point of junction of the horizontal and vertical parts being joined by a "mitre" joint, at *f* (see "Joints" in a succeeding paragraph). A moulding is said to be "struck on" when it is struck or formed upon the framing, as at *c* in fig. 72; it is said to be "laid on" when it is laid on the panel, as at *a* in fig. 73—its end, as

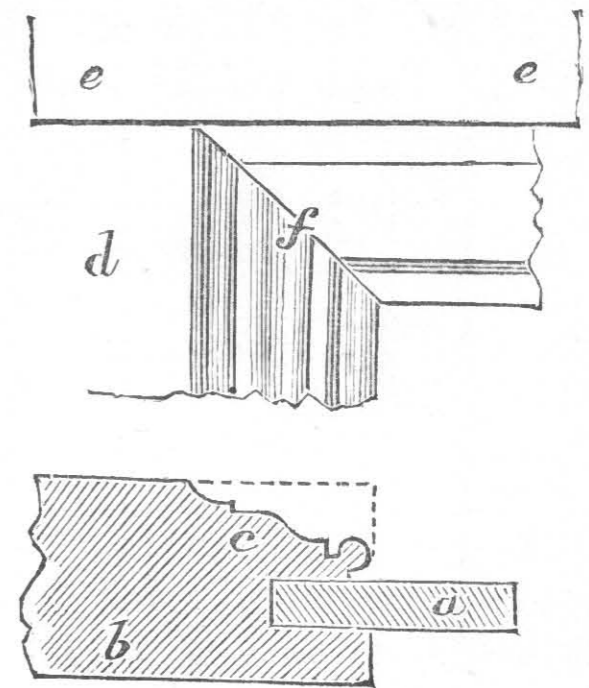

Fig. 72.

b, butting against the edges of the style or rail, *c*. In this case the moulding may be nailed either to the panel, *d*, or to the rail or style, *c*, but it should not be nailed to both, as when the framing "gives," and the panel leaves the framing, or *vice versa*, the expansion will cause the

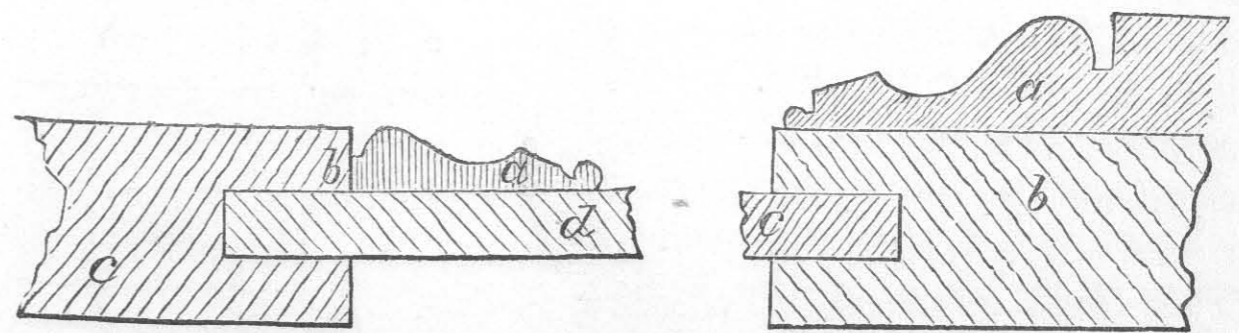

Fig. 73.

Fig. 74.

moulding, *a*, to be split at the nail parts. When the panel is "flush" the mouldings, *a*, are laid on the style or rail, as *b*, fig. 74. When mouldings are laid on to either panels or the framing, they are formed in long lengths, and cut up to the requisite lengths, and mitred at the corners, as at *f* in fig. 72. When mouldings

project from any surface, they are generally termed "bolection" mouldings.

27. Windows.—In fig. 75, in *a* and *b*, we give sketches illustrative of the ordinary form of sash windows. Sash windows are either "fixed" or "hung."

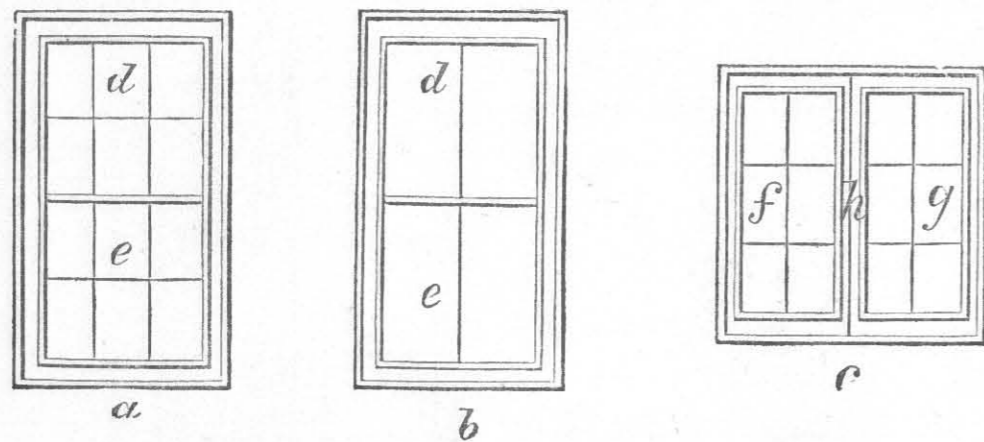

Fig. 75.

If "fixed," the window is of course not capable of being opened; if "hung," it may either be "single-hung" or "double-hung." If single-hung, the lower sash, as *e*, fig. *a*, in fig. 75, is capable of being lifted up, the upper sash being fixed, or *vice versa*. The upper sash in a single-hung window is, however, that which is usually made capable of being opened by being lowered. If the window is "double-hung," the lower sash, *e*, is made to lift up; the upper sash, *d*, to pull down. In what is called a "casement window," as at *c* in fig. 75, the two leaves or sashes, *f* and *g*, are hinged to the frame or casings at their outer edges, and are made to open inward towards the room, or outwards towards the exterior, the inner edges butting or closing against the central part, *h*. This form of casement window is that generally used for kitchens and sculleries. Fig. 76 illustrates two forms, *a* and *b*, used for superior rooms and frequently termed "French casement windows." A mode of making a casement window is shown in *b*, fig. 76. In this the two upper compartments, *c* and *d*, are fixed; the two leaves, *g* and *f*, open right and left. Windows are sometimes made so as to open by sliding horizontally into grooves or recesses formed in the walls. In factory buildings,

the windows are formed with an upper part, as *c* and *d* in *b*, fig. 76; this turning on pins at the centre of the ends, so that it can be made to be horizontal, or opened at any less angle, or the part, *c d*, may be hinged at its lower edge to the cross bar, *e e*, and opened at any angle required, being kept in this position by cords and pulleys.

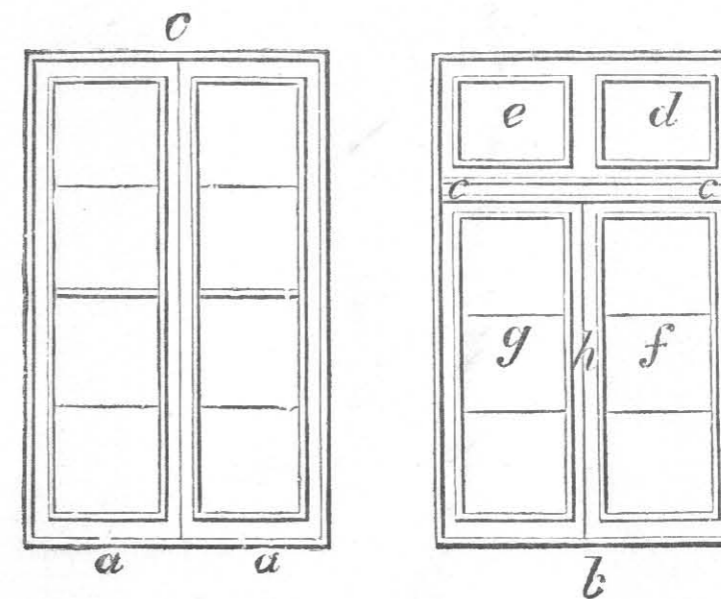

Fig. 76.

In "fixed" sash windows, the window proper is inclosed in a frame fixed in the wall, called a "solid sash frame," the sides of the opening made in the wall being boarded. But in the case of a balanced sash, *i. e.*, a single or double-hung sash—the frame at the sides is made as shown in fig. 3, Plate XIV., and is called a "cased framing"—the sides are hollow, as at fig. 3, Plate XIV., and the top-piece or "head" is similar to the head of a door frame (see *c*, fig. 67); the bottom of the frame is called the "sill" or "cill," as *a* in fig. 77, and is generally made of oak. If the part of the sill outside of the window is made sloping, as *b*, fig. 77, in order to admit of the rain falling on it being quickly carried away; if there are more than one sloping face to the sill, it is called a "double sunk sill," the first on *b* being separated from the second on *e*, fig. 77, by a splayed, or bevelled, or by a curved face as shown. The oak sill of the window casing frame rests upon the stone sill, as at *a*, fig. 5,

Plate XIV; *b*, the lower bar of sash. The parts making up the sides of the window frame are shown at fig. 3, Plate XIV., the sides being known as the "casing pieces," or "casing;" in this, *b b* is the "pulley style," or "pulley piece;" the office of which is to carry at the upper part of the style, near the head of the window, the pulleys

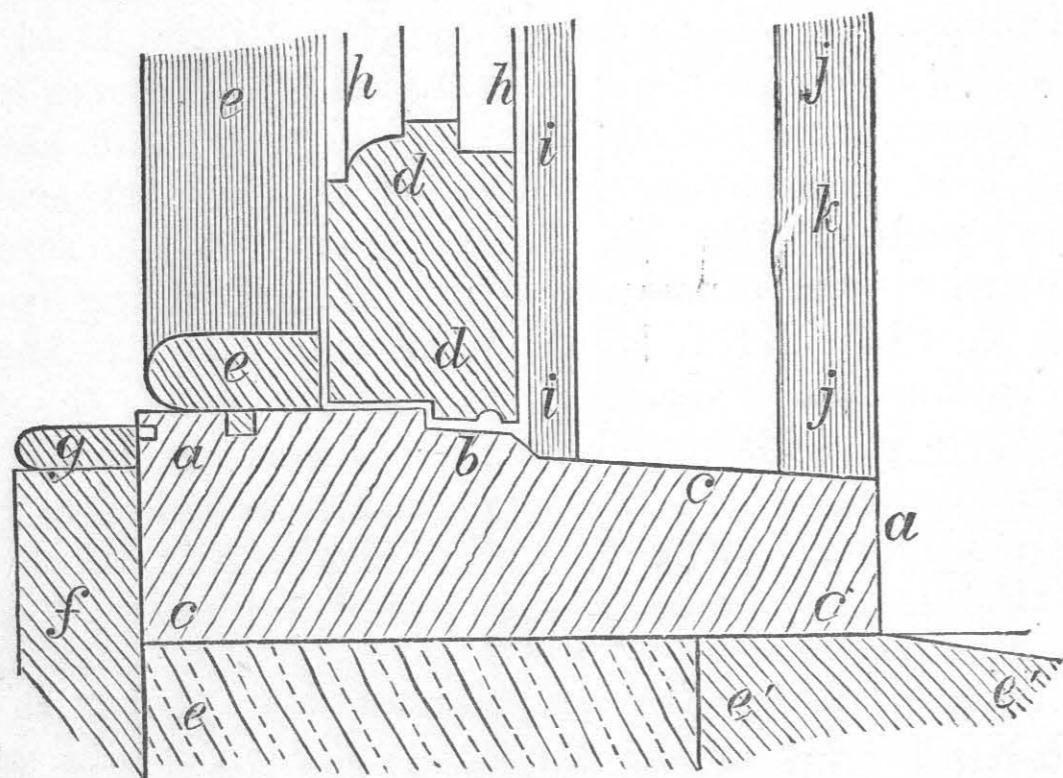

Fig. 77.

over which is passed the cord, one end of which carries a heavy weight, *c*, to counterbalance the sash, as *a a*, to the side bar of which the other end of the pulley cord is fixed. The "sash weight," *c*, is that for the upper sash *a a*, *d* is the weight for the lower sash, which slides in the part *e e*. Between the two sash weights and separating them, so that they and their attached cords may not get entangled, is the "parting slip," shown at *d*, fig. 3, Plate XIV. The "pulley piece," *b b*, is secured at the end toward the outside of the window to the piece *e f*, called the "outside lining" at the other, or inside end, to the piece *g*, called the "inside lining;" these two linings being joined by a third piece, *h h*, called the "back lining," parallel to *b b*. As the bead, *i*, fixed to the "inside lining," *g*, is called the "inside bead;" that to the "outside lining," *f*, the "outside bead." The outer end of *f* is

sometimes worked round to form a bead, as shown by the dotted lines. The bars of the upper and lower sashes are kept separate by, and made to slide up and down in the groove, or recess formed by a piece of wood called the "parting bead," as *j*, fig. 3, Plate XIV. All these pieces run from top to bottom of the window opening, being secured at bottom to the sill, at top to the head of the framing (see figs. 2 and 5, Plate XIV.) The reader will, of course, understand that the arrangement shown at fig. 3 is repeated in the case of an ordinary sash window, such as *a* in fig. 75; each end of the same sash being hung to a balance weight, corresponding to *c d* in fig. 3, Plate XIII. Fig. 1, in this plate, is the front elevation of a "three-light window;" when the central part, *a a*, of a window of this sort is much wider than the side parts, the arrangement is called a "Venetian window." Fig. 4 is plan of the part, *d d*, of fig. 1, Plate XIV., one side of which covers the "casing" or "casing pieces" of the right-hand side bars of window, *b b*, fig. 1 (fig. 3 showing the casing bars for left-hand bars of window); while the other side of the central line, *a b*, fig. 4, covers the casing pieces of the left-hand side of window, *c c*, the right-hand casing pieces of this being precisely like the drawing in fig. 3, only reversed in position—that is, with the "back lining," *b b*, towards the right hand, in place of to the left, as in fig. 3, Plate XIII. In fig. 4, *c d*, the "pulley pieces" or "pulley styles;" *e e*, "outside lining;" *f*, "inside lining;" *g g*, "inside bead;" *h h*, "outside bead;" *i i*, "parting bead;" *j j*, the "sash weights" (double for the two windows, *b b* and *a a*, fig. 1), separated by the "parting slip" made in the form of a cross, as shown. In fig. 77, the part of the lower or bottom bar of a sash window is shown, *e e* being the beaded "inside lining," corresponding to *i* in fig. 3, Plate XIV.; *i i*, the "parting slip" or "bead," corresponding to *j*, fig. 3, Plate XIV.; and *j j*, fig. 77, the "outside lining," corresponding to *f*, fig. 3, Plate XIV. In fig. 78, the meeting of the sash bars of the lower sash, *a*

(corresponding to *e* in *a*, fig. 75), and upper sash, *b* (corresponding to *d* in *a*, fig. 75), is shown,—*d*, the upper cross bar or rail of lower sash, corresponding to *e* in *a*, fig. 75, and the lower rail of which is at *d d*, fig. 77; *d'*, the lower cross bar or rail of upper sash, corresponding to *d* in *a*, fig. 75. The upper and lower halves are technically termed “sheets,” *e e*, *h h*, *i i*, *j j* correspond to same parts as in fig. 77, *e e*, being the “inside lining;” *j j*, the “outside lining;” *i i*, the “part-

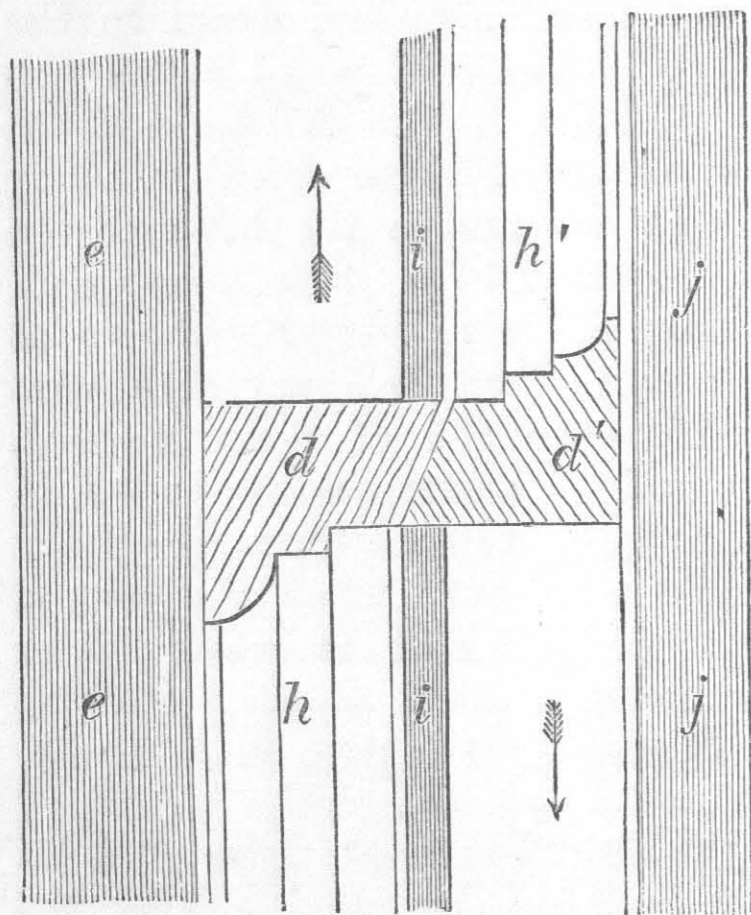

Fig. 78.

ing slip” “or bead.” In fig. 79, *c* is the upper or cross bar of upper sash; the letters indicate similar parts as in figs. 77 and 78.

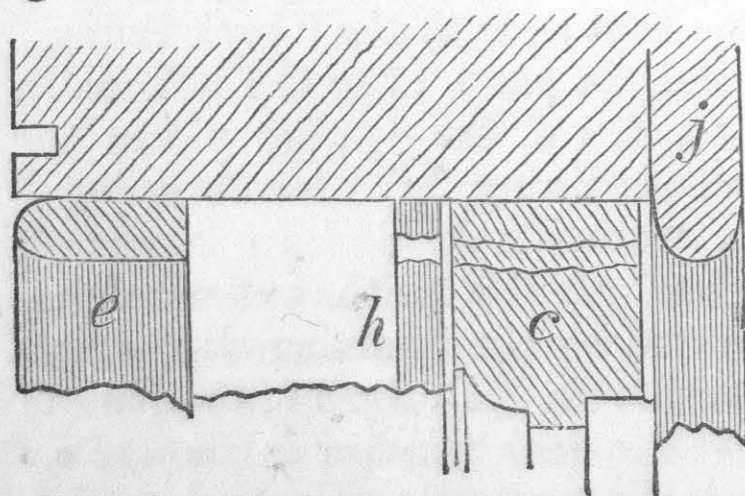

Fig. 79.

The panes of glass of a sash window are fastened to the “astragals” or “sash bars,” which are so placed as to form squares or rectangles, as shown in fig. 75. The forms or sections of the “sash bars” vary much, according to the design of the building, or taste of the architect. A very common form is illustrated in fig. 80, at *a a*, which is known as the “lamb’s tongue sash bar.” The

The panes of glass of a sash window are fastened to the “astragals” or “sash bars,” which are so placed as to form squares or rectangles, as shown in fig. 75. The forms or sections of the “sash bars” vary much, according to the design of the building, or taste of the architect. A very common form is illustrated in fig. 80, at *a a*, which is known as the “lamb’s tongue sash bar.” The

glass is shown at *b b* towards the outside, being secured at *a* and *d* by putty, *c c*, or by a small bead or fillet, *i*, same figure. *f f*, *g g* is the front elevation, showing the

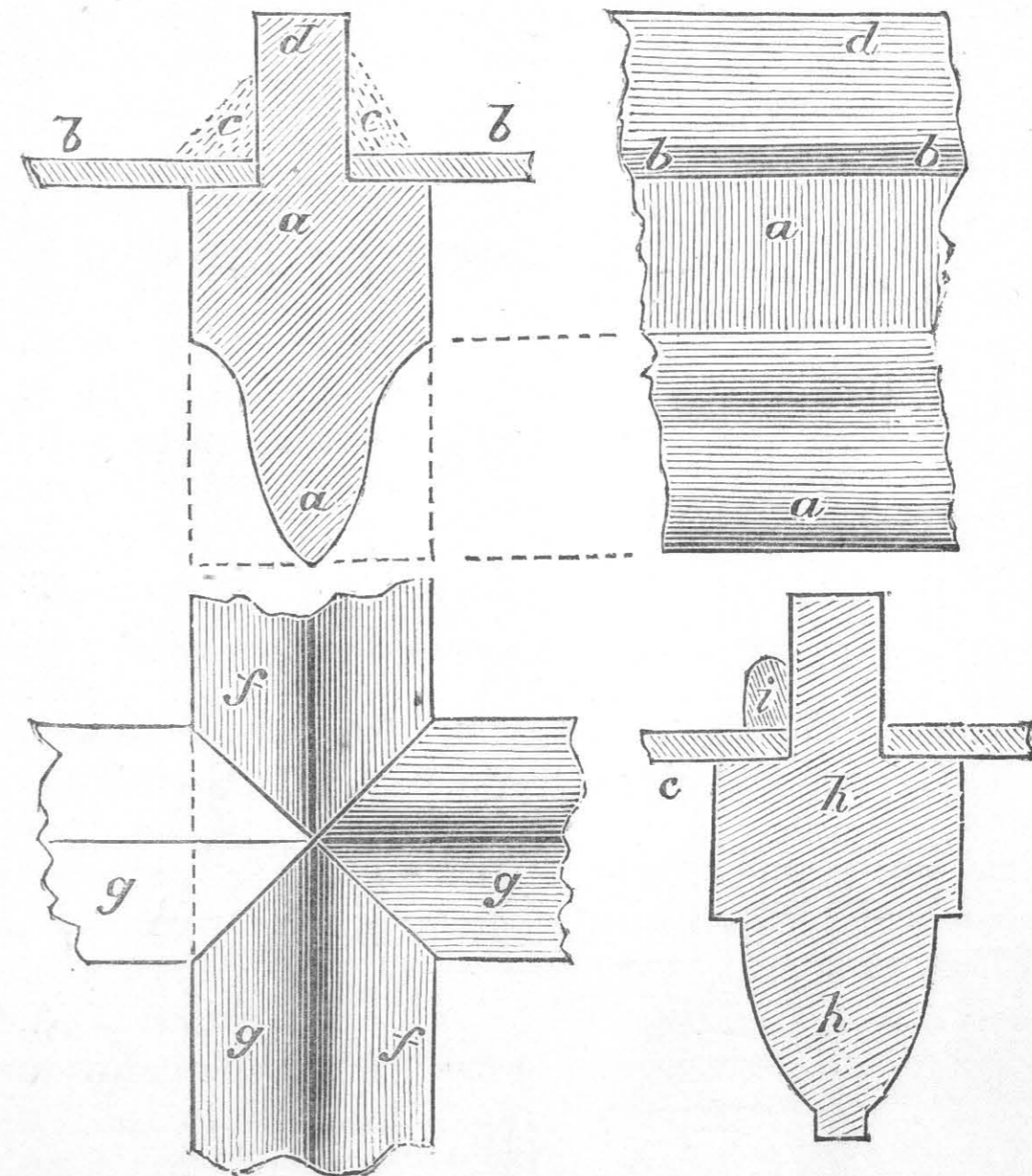

Fig. 80.

junction of a vertical sash-bar, *f f*, with a horizontal one, *g g*. Another form of sash bar is shown at *h h*, in fig. 80, and at *a a*, in fig. 81. In fig. 82, the junction of the horizontal bars, *b b*, *d d*, with the vertical, *a a*, *c c*, are shown. *a a*, *b b* being the front elevation of *a a* in fig. 81; *c c*, *d d* of *h h* in fig. 80.

28. Shutters to Windows.—These are generally provided to windows, and are of several kinds—“folding,” “lifting,” and “rolling.” Folding shutters are illustrated

in fig. 83, which are those for a superior room, as they fold into and are inclosed by what are called "shutter boxings." The boxing is made up of two side linings and a back lining. The side lining next the window is in fact the "inside lining" of the window casing, part of which

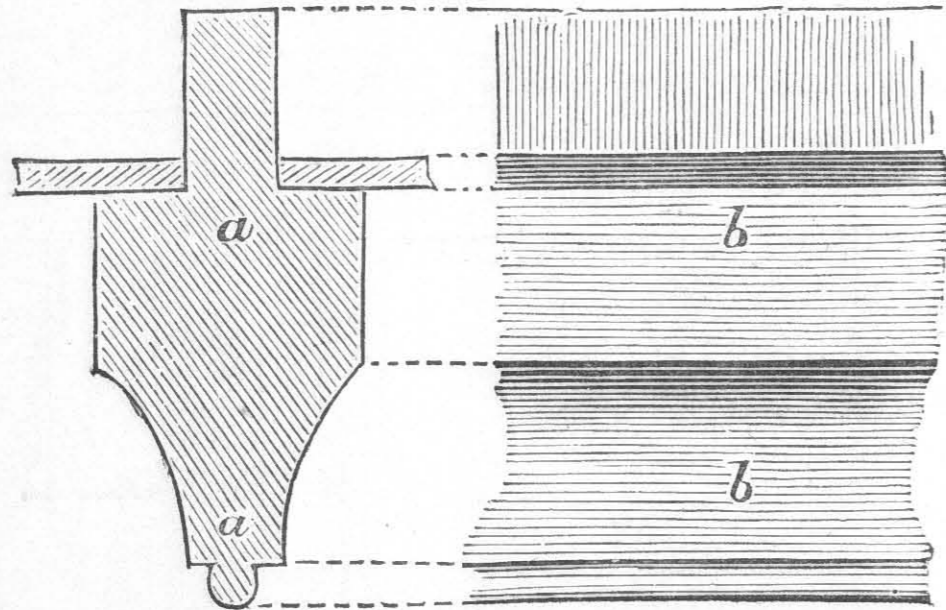

Fig. 81.

is shown by the line *a a*, fig. 83. The other side of the shutter boxing is at *b b*, and the "back lining" is at *c c*.

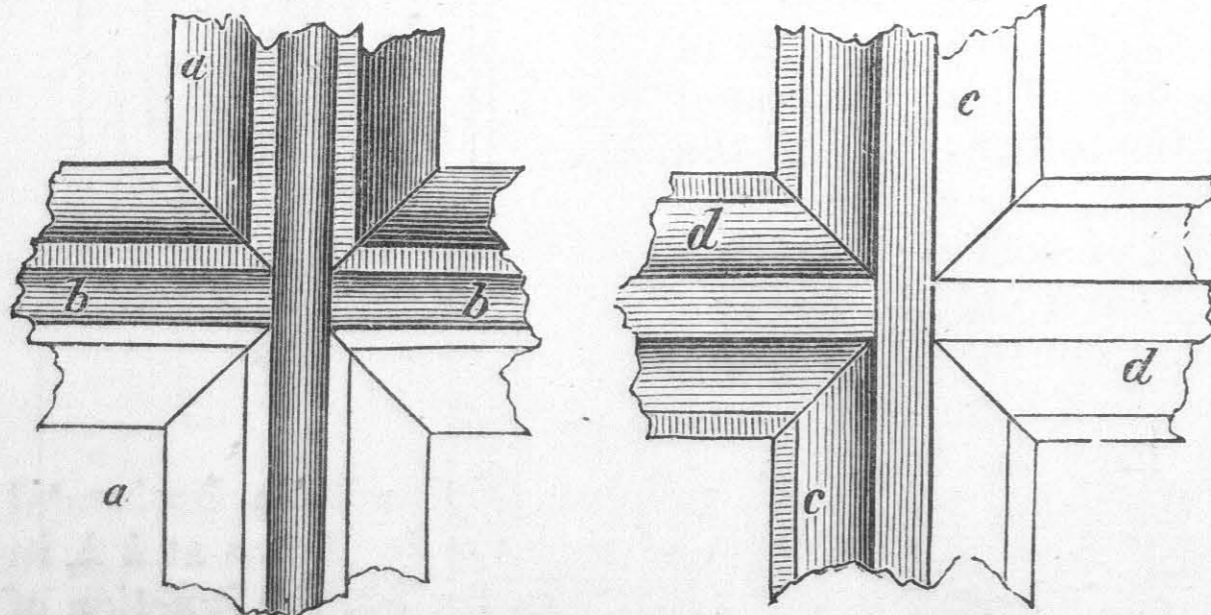

Fig. 82.

The side, *b b*, forms the "ground" to which the "architrave," *d d*, is secured; *e e*, the plastering keyed into the side lining of boxing. In superior work the back lining is panelled at *f*, to show finished work when the folding shutters—called "flaps"—as *g g*, *h h*, *i i*, are pulled

out in order to cover the window. The front of the shutters, as *g g*, is called the "front flap" or "first flap;" *h h*, the "second back flap;" *i i*, the "back flap." The "front flap" is generally panelled in front, so that—as

in the day time—when the shutters are in their place in the boxing, the front or outside of *g g* may be ornamental. If the flap is very broad, it may be panelled in two. Fig. 83 is a cross section of the shutter and shutter boxing, showing the thickness of the pieces. In elevation the length of the shutter would show equal to the height of the window to be covered. The bottom of the shutters slide above, and rest a little above upper face of inner sill. The arrangement shown in fig. 83 is of course repeated at the other side of the window, the shutter flaps being of such a width that they cover only half of the breadth of the window, the other half being covered by the flaps in the boxings at the other side. Other forms of shutters will be found, described and illustrated, in *Building*

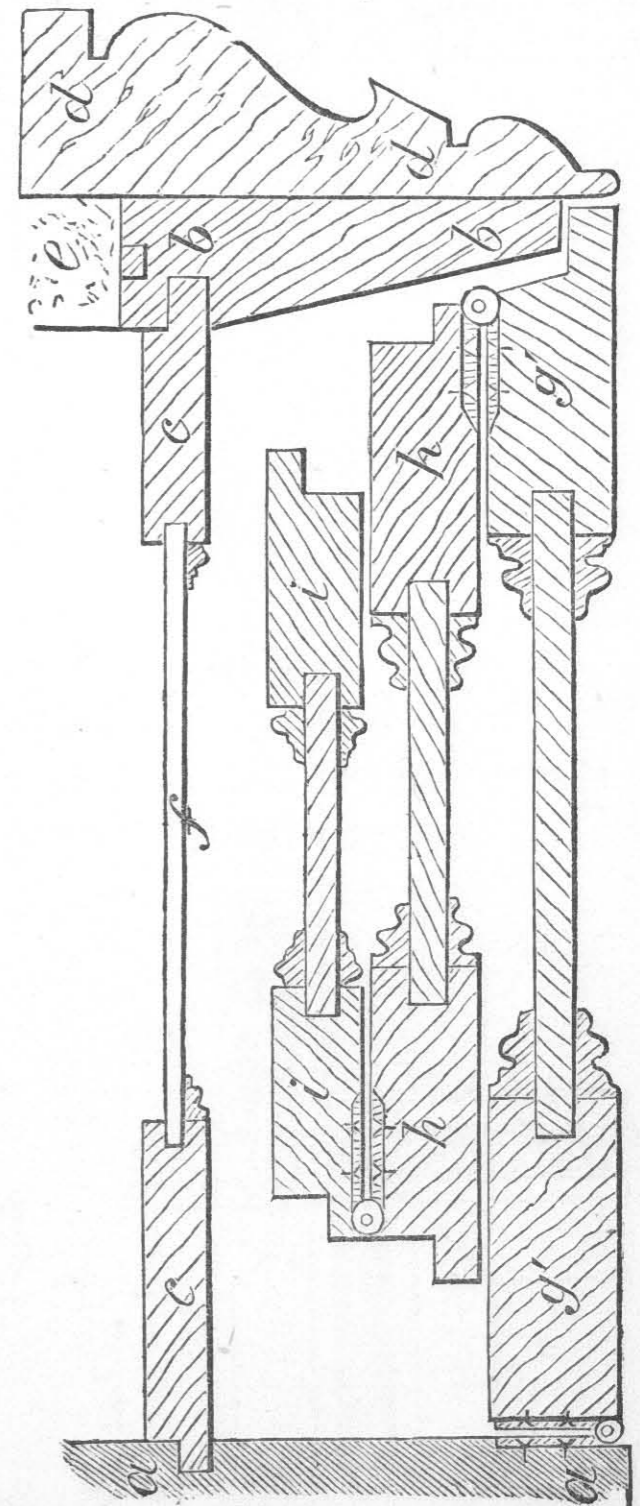

Fig. 83.

Construction, Advanced Course, in this series.

29. Hinging of Doors and Windows.—The hinging of doors is a work involving considerable nicety in laying out the lines for the joints of the various parts; and

will be found more fully described in the volume forming the advanced course in this series. We can only glance at one or two of the simpler methods in use. In fig. 84, we give the elevation — half actual size—of a very commonly met with hinge. This is shown as fully open or extended, being attached at one end to the style *a a*, and at the other to the style *b b*; when closed, they are as at *a b*, in fig. 86.

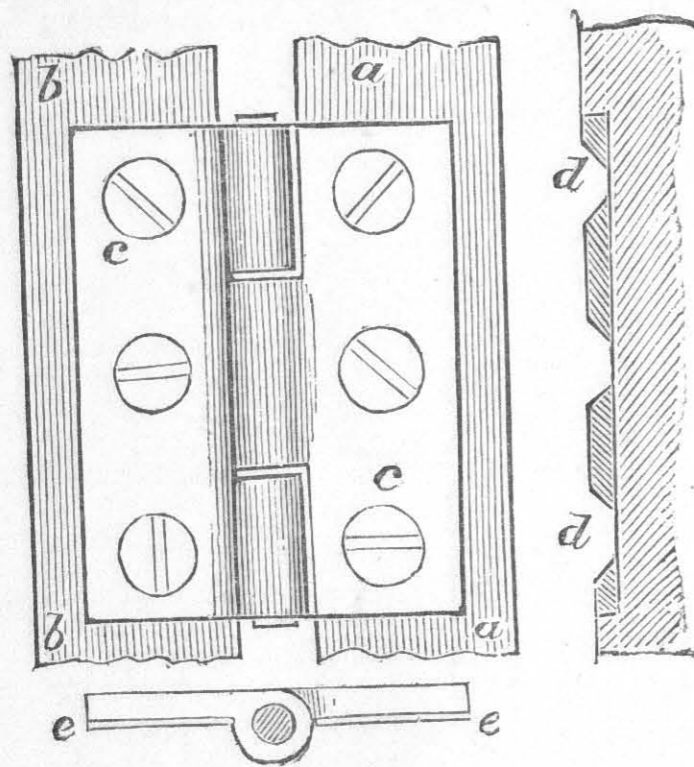

Fig. 84.

The hinges in rough work are simply screwed to the surface of the wood, so that they project beyond its surface; in better class work, they are sunk so as to be flush with the surface of the wood, as in fig. 85. In fig. 84, *d d* shows how the screw-nail holes are countersunk, so that, when screwed home, the surface of the end of screw-nail, *c c*, is flush with the surface off hinge; *e e* is the end view of hinge. Fig. 85 shows the application of this simple form of hinge to the hanging of a door, in which *a* is part of the “lock style” of the

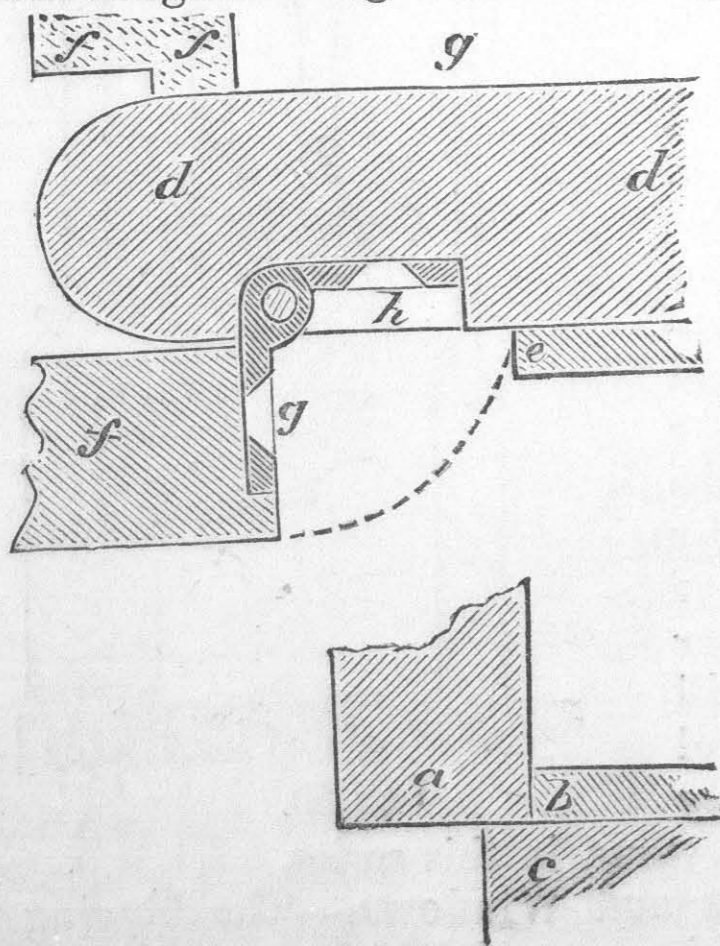

Fig. 85.

a door, in which *a* is part of the “lock style” of the

door, going into the rebate, *b*, of the jamb lining, *c*. The lining at the opposite side of the door is at *d d e*; *f* is part of the hinging style of the door, in the position which it assumes when wide open, at right angles to the door opening; *g* is the half of the hinge sunk into the edge of style, *f*; *h*, the other half sunk into recess in jamb *d d*; *f f*, plaster of wall; *g*, wall. Fig. 87 shows the form of hinge joint known as a rule joint. Fig. 88 shows a form of hinge joint, which prevents any one seeing through the line when the door is opened.

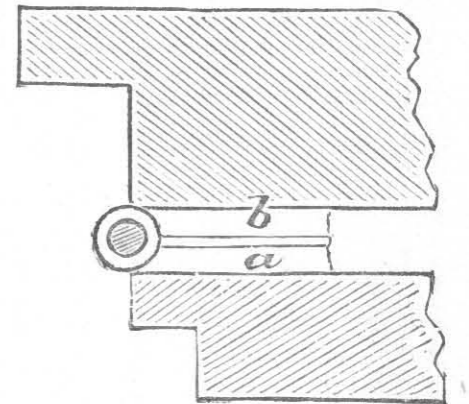

Fig. 86.

Fig. 87 shows the form of hinge joint known as a rule joint. Fig. 88 shows a form of hinge joint, which prevents any one seeing through the line when the door is opened. Fig. 86 illustrates the usual method of hinging shutters; sometimes they are let into the flaps. The lock of a door is secured to the “lock style” of the door, at a convenient height from the door, generally about the centre of the middle rail. Locks are of various kinds. A “mortise lock” is concealed within the thickness of the style, nothing being seen but the handles on either side and the key-holes. The key-hole is covered with a hanging cover called an **escutcheon**. A “rim-lock” is placed on the outside of the door style, and is of course visible, as also is the part which receives the bolt of the lock when the door is locked; this being secured to the jamb lining of the door frame. Bolts are generally provided to doors as well as locks, and are usually placed immediately below the lock. It is a good plan, for further security, to have sunk bolts placed at top and bottom rails.

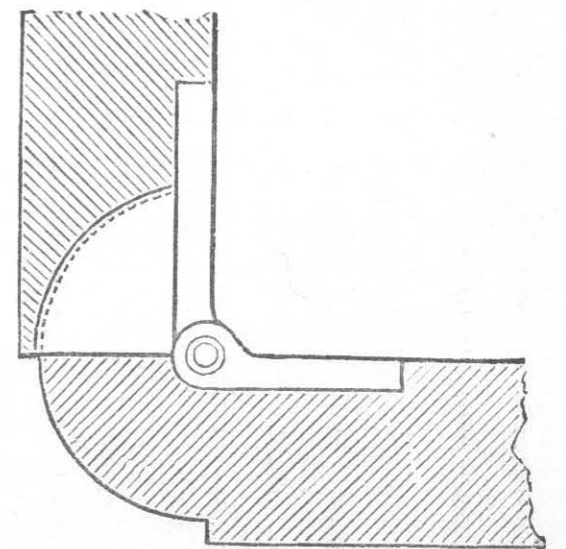

Fig. 87.

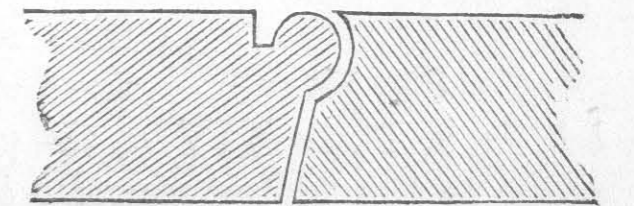

Fig. 88.

Fig. 86 illustrates the usual method of hinging shutters; sometimes they are let into the flaps. The lock of a door is secured to the “lock style” of the door, at a convenient height from the door, generally about the centre of the middle rail. Locks are of various kinds. A “mortise lock” is concealed within the thickness of the style, nothing being seen but the handles on either side and the key-holes. The key-hole is covered with a hanging cover called an **escutcheon**. A “rim-lock” is placed on the outside of the door style, and is of course visible, as also is the part which receives the bolt of the lock when the door is locked; this being secured to the jamb lining of the door frame. Bolts are generally provided to doors as well as locks, and are usually placed immediately below the lock. It is a good plan, for further security, to have sunk bolts placed at top and bottom rails.

The sash-frames, already illustrated, show what are "cased framings," so called from the framing, as at *h h*, *b b*, fig. 3, Plate XIV., being made hollow, or like a case, to contain the sash weights, and are adapted to "hung" sashes. These are sashes capable of being moved up and down. If both sashes, the upper and lower, are capable of being so moved,

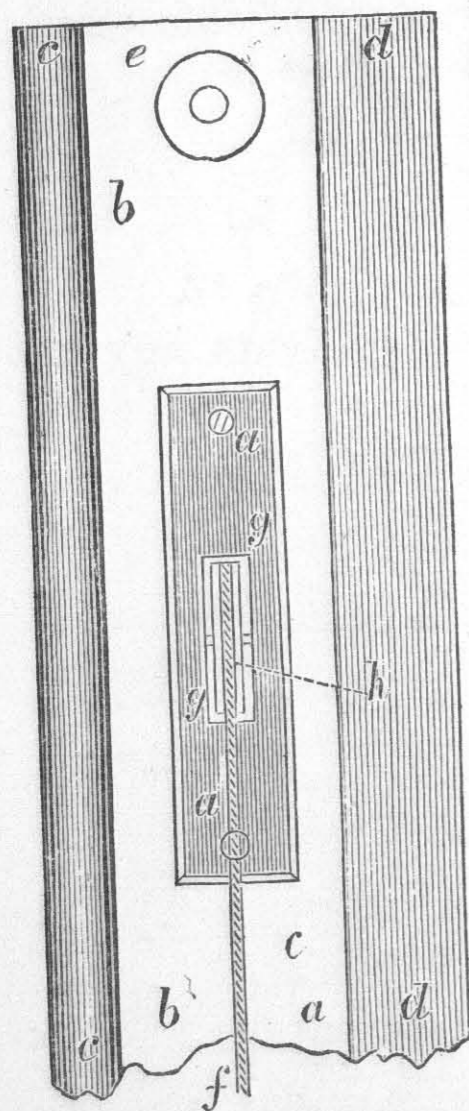
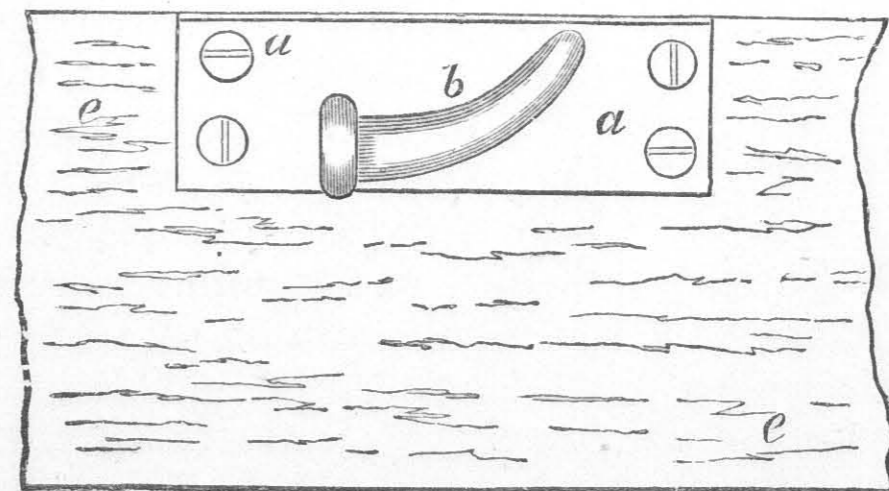
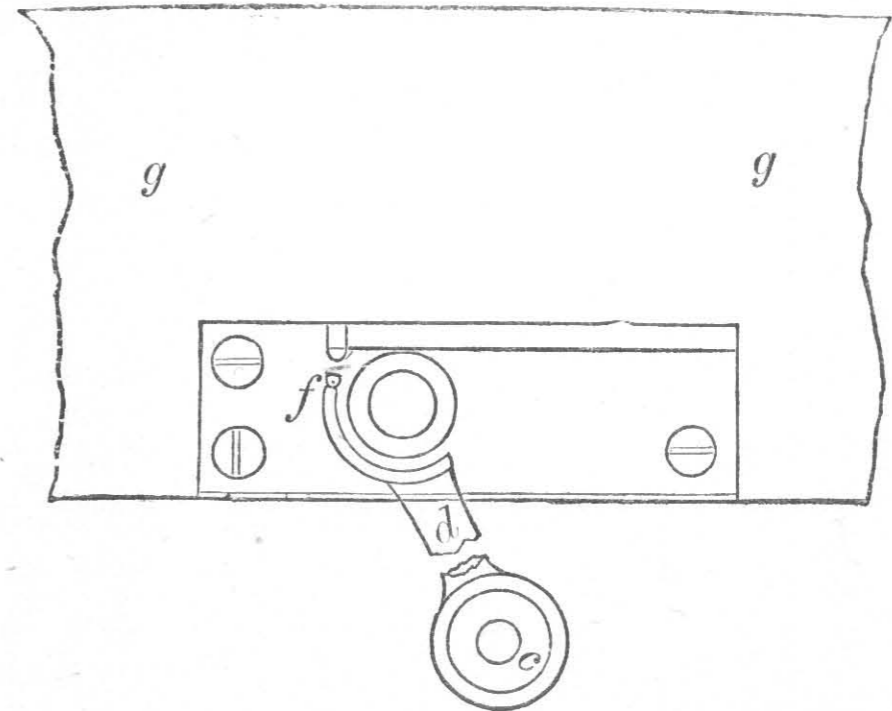

Fig. 89.

the window is said to be "double-hung;" if one only is capable of being moved up and down, it is said to be "single-hung." Where the window frames are "solid," the upper sash is fixed, the lower only being made capable of being moved up and down, sliding between the parts as between *f* and *i*, fig. 3, Plate XIV., at *e e*. The window in this case is fixed at any desired point of vertical opening by a jointed catch, the termination of which slips into notches made at desired intervals in the bead of lining of frame. The cords for suspending the sash-weights, *c d*, fig. 3, Plate XIV., pass over "pulleys" fixed in the pulley style, *b b*, same fig. In fig. 89, we give a sketch of the pulley piece, which is fixed into a mortise or aperture cut in the face of the pulley piece or style, *b b*, fig 3, Plate XIV. *a*, the pulley frame, secured by screw-nails to the pulley piece, *b b*; *c c*, the outside bead; *d d*, the inside bead of window lining; *e*, the bearing, *a*, for the axis of the roller for the window blind; *f h*, the rope or cord, the lower end of which is attached to the upper cross bar of the lower sash; the cord passing over the pulley, *g g*, and terminated at the end by the sash weight, *c*, fig. 3, Plate XIV. Windows are secured from being lifted or lowered by locking the upper and lower sashes together by

means of a "catch." This is illustrated in fig. 90; and the part *a* is screwed down to the top surface of the upper cross bar or rail of the lower sash; the part *a a* being secured to the upper cross bar of the lower sash; *b* is a horn, over which the bar, *d*, is brought by the handle *c*, a spring at *f* bringing back the bar or lever, *d*, when it is released from the horn; *g g* shows part of the lower cross bar of upper sash; *e e* the upper cross bar of the



1/2 size

Fig. 90.

lower sash. For the convenience of lifting the lower sash, finger or "thumb bows" or "hooks," as *a a*, in fig. 91, are secured, two to each sash, to the lower cross bar or rail,

b b, of the lower sash. In fig. 91, *b* shows a "moulded," *c*, a "bevelled," and *d*, a "square," sash bar or cross rail, the side rails or styles being finished in the same way all round, mitreing at the corners. In fig. 91, *e* is the glass pane; *f*, the putty, which secures it to the cross bar rail. It is a convenience to have a ring or bowe attached to the top cross bar of the upper sash, in the centre; by means of a hooked rod, the upper sash may, by the aid of this hook, be raised or lowered very conveniently.

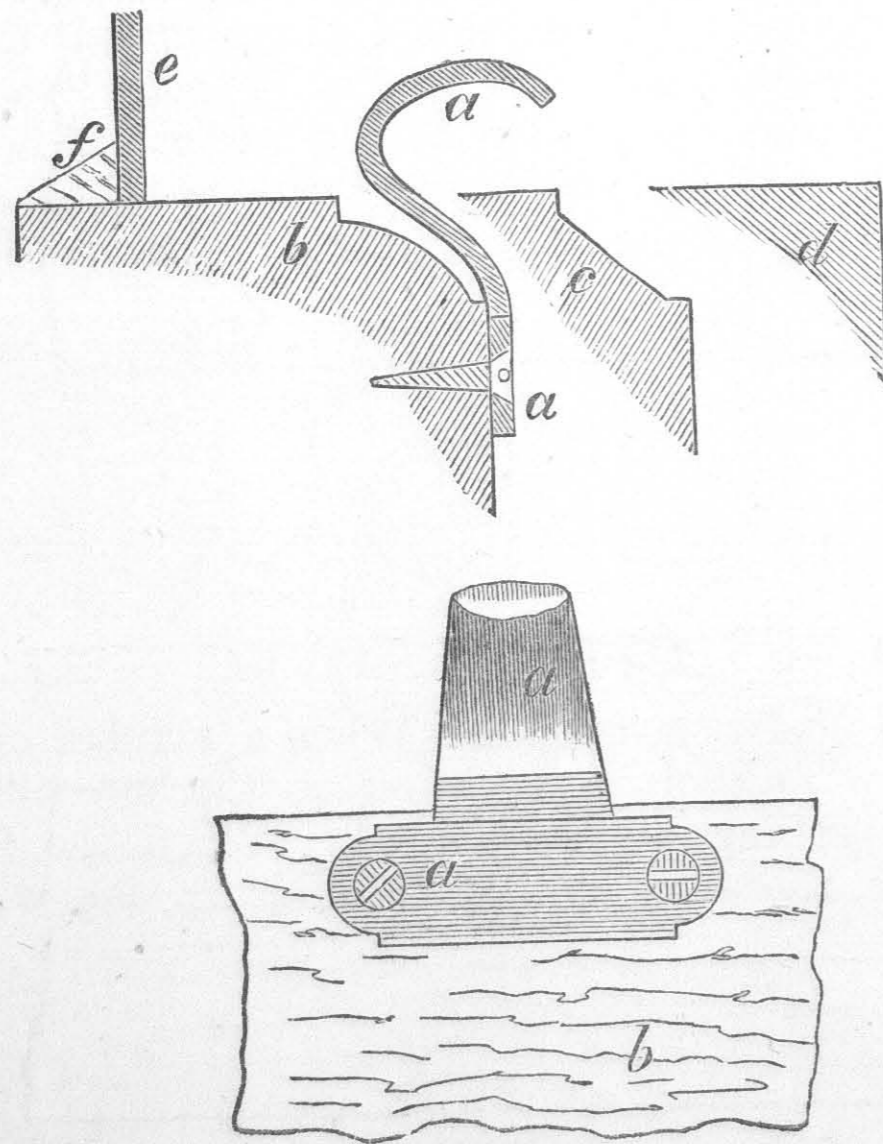

Fig. 91.

30. Method of Joining Pieces of Timber in Joinery Work.—Before describing the more simple forms of joints used in putting doors, windows, and internal

fittings together, we illustrate the forms of ordinary mouldings used in decorating work. The methods of describing or setting out the curves of such will be found in the volume in this series on *Technical Drawing, for the use of Students of Architecture and Building*; and illustrations will also be found in *Building Construction, Advanced Course*, in this series of technical educational works, of the more complicated and higher class of mouldings, Gothic and the like. In fig. 92, *a* is the "fillet," with a flat face as shown; the office of this is to divide mouldings of different or of the same character from each other. In the same figure, *a*, *b*, and *c* are three fillets in conjunction. Fig. 93 is the "torus" or "round," being a projection from a surface of half or a semi-circle. When small, the torus is called a bead. When the bead, *a*, fig. 93, projects from the surfaces, as

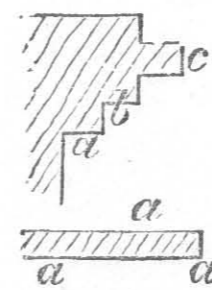

Fig. 92.

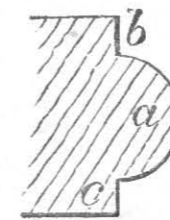

Fig. 93.



Fig. 94.

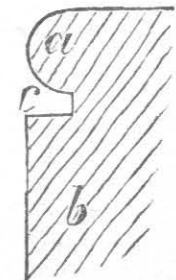

Fig. 95.

b c, it is called a **cock-bead**. When a number of small beads run parallel to each other, the assemblage is called a **reeding**, as in fig. 94. When the bead is flush with the face, as the bead *a*, fig. 95, with the

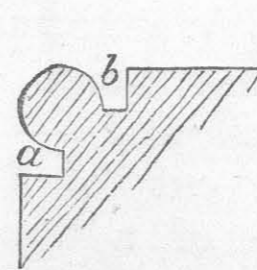

Fig. 96.

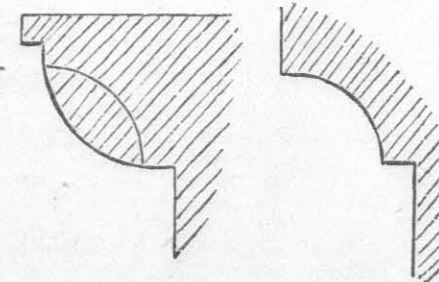

Fig. 97.

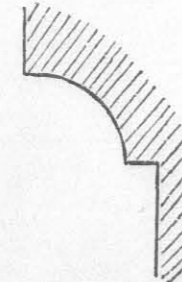

Fig. 98.

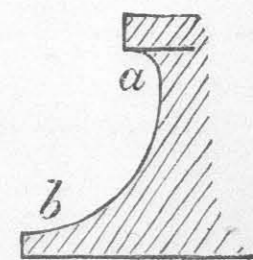

Fig. 99.

face *b*, the bead is called a **quirk**, or **quirked bead**. When the returns, as *c*, are two in number, as

a b, in fig. 96, the bead is called a **double quirk**. Fig. 97 is the "ovolo," or "quarter round." Fig. 98 is the "cavetto," or "hollow," which is a quarter of a circle reversed. Fig. 99 is the "scotia." Fig. 100 is the "cyma recta," or "cymatium," in which the hollow, *a*, is at the top, the round, *b*, at bottom. In the "cyma reversa," or "ogee," fig. 101, the round, *a*, is at the top, and the hollow, *b*, is at the bottom of the moulding. Fig. 102, the "congee," being the curve used to connect a horizontal fillet, *a*, with a vertical part, *b*.

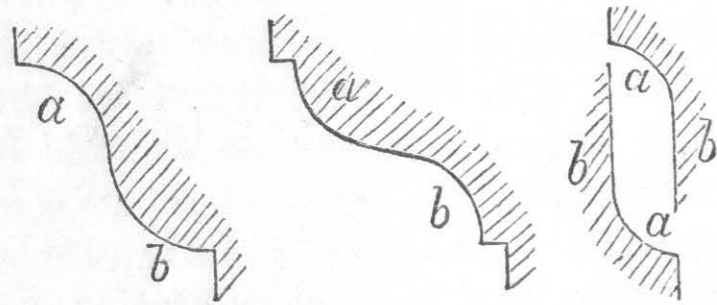

Fig. 100. Fig. 101. Fig. 102. We now come to describe the different methods of joining timbers together under the head of

31. Joints Used in Framing Doors, Windows, &c.—

In joining narrow boards together in order to make a broad surface, as the boards forming a door, there are various methods employed. When the boards are planed, with their edges left square, they are said to be "shot," as at *a a a*, fig. 103; *b b b* being the boards in section. When a small part — square or rectangular — is cut out of the edge of a board, taking away part of the edge, *c*, and part of the face, *d*, fig. 104, the edge is said to be made with a

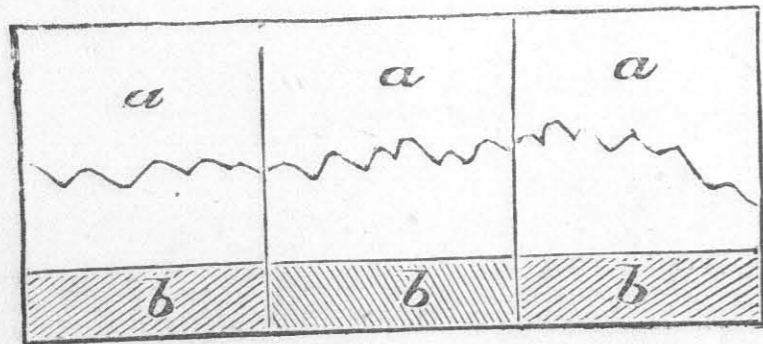

Fig. 103.

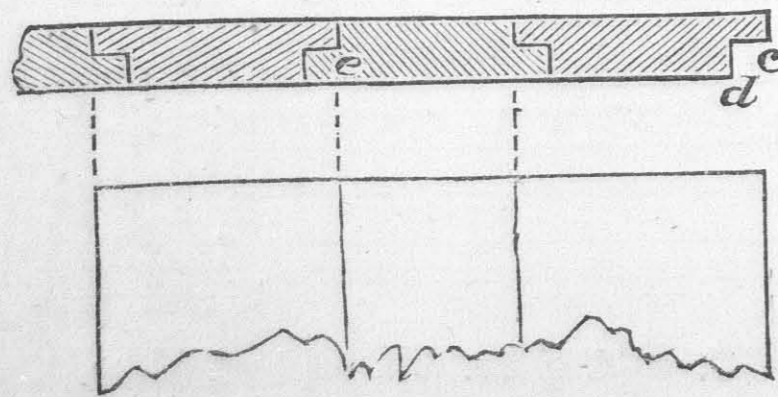

Fig. 104.

face, *d*, fig. 104, the edge is said to be made with a

"rebate;" and boards placed together, as at *e d c*, are said to be "rebated." When a small groove, as *d a b*, fig. 104, is cut out of the edge of the board, it is said to be "ploughed" or grooved, a corresponding projection being cut in the other edge, as *c d*, this being called a "tongue" or "feather." Boards put together this way, as *e e e*, are said to be "matched," sometimes "ploughed and feathered," and sometimes "ploughed and tongued," although this latter term is applied sometimes to the method illustrated in fig. 106, in which both of the edges of the boards are ploughed or grooved, as at *a b*, fig. 105, the boards brought together, as at *c*, and a narrow piece of wood (shown at *e e* in side, and at *f f* in edge view, called a **tongue**, or **slip feather**) driven into the space, *c*, as at *d*; *g g* shows one of the edges of a board. In "matching" boards, as in fig. 106,

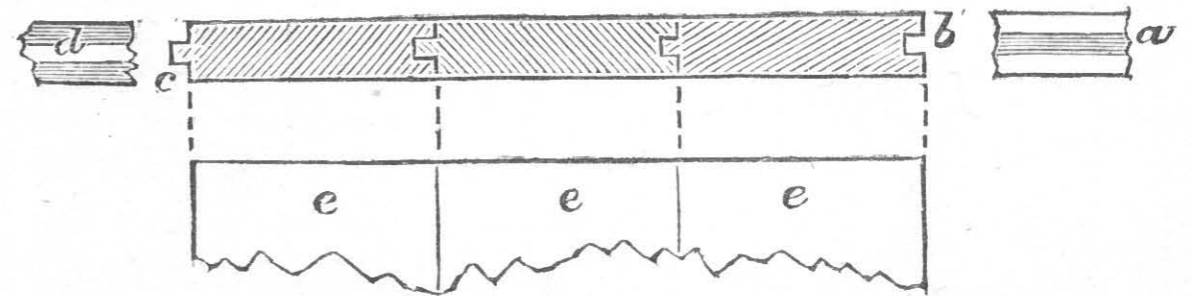

Fig. 105.

the plough or groove is formed, as in fig. 107, at *a*; the tongue or feather, *b*, being of the same section; *c c* is

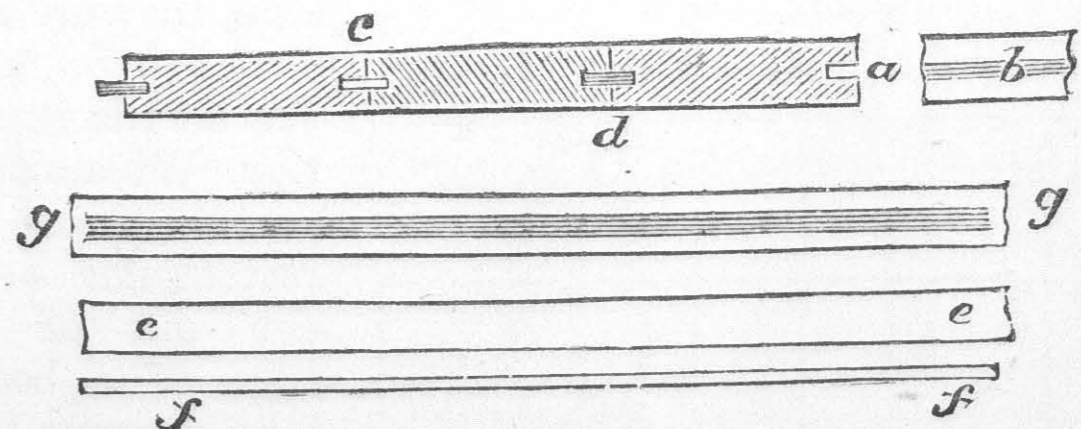

Fig. 106.

the ploughed edge of a board done in this way. Rebated boards, with fillets *a* and *b*, are illustrated in fig. 108; *c c*

being elevation of the fillets, and *dd* of the boards. In fig. 109, we illustrate three other methods of joining boards with moulded edges. *e, ff,* and *gg* are the elevations of the sections at *ab* and *cd*. Boards are

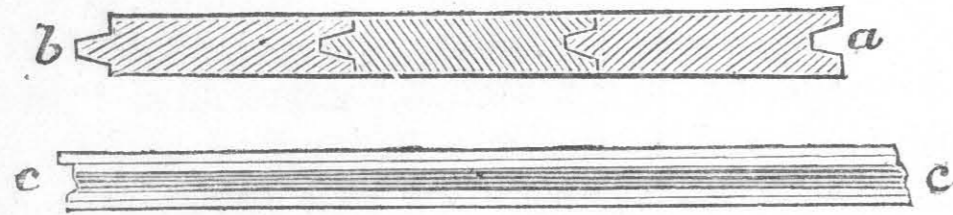

Fig. 107.

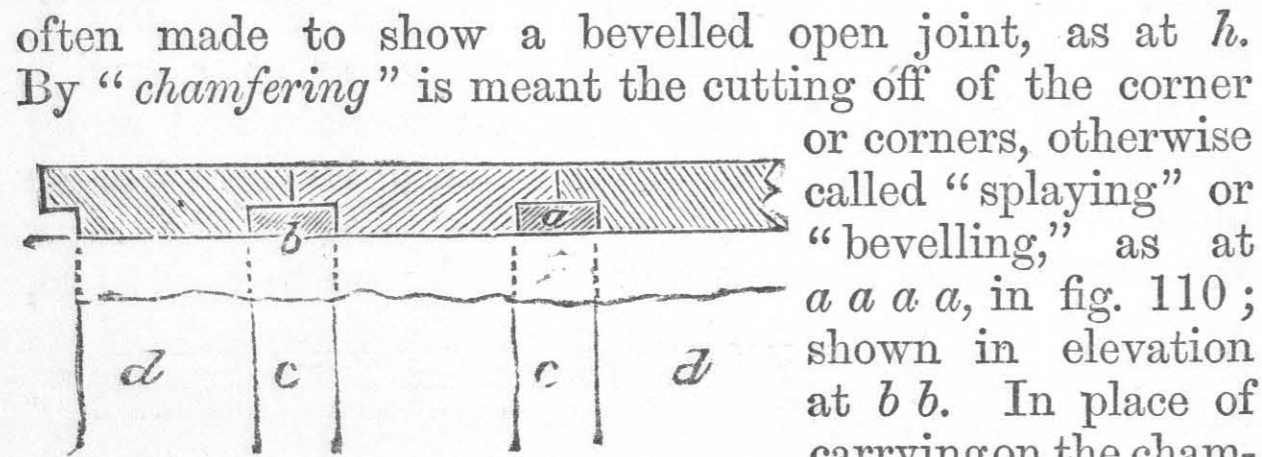

Fig. 108.

often made to show a bevelled open joint, as at *h*. By "chamfering" is meant the cutting off of the corner or corners, otherwise called "splaying" or "bevelling," as at *aaaa*, in fig. 110; shown in elevation at *bb*. In place of carrying on the chamfer or bevel from one end of the piece to the other, as at *bb*, it is sometimes stopped at some distance from the ends, as at *cd*; this being called a "stop chamfer; the sharp corner, as *c'*, being met with a curve, as shown at *cd*, and in side eleva-

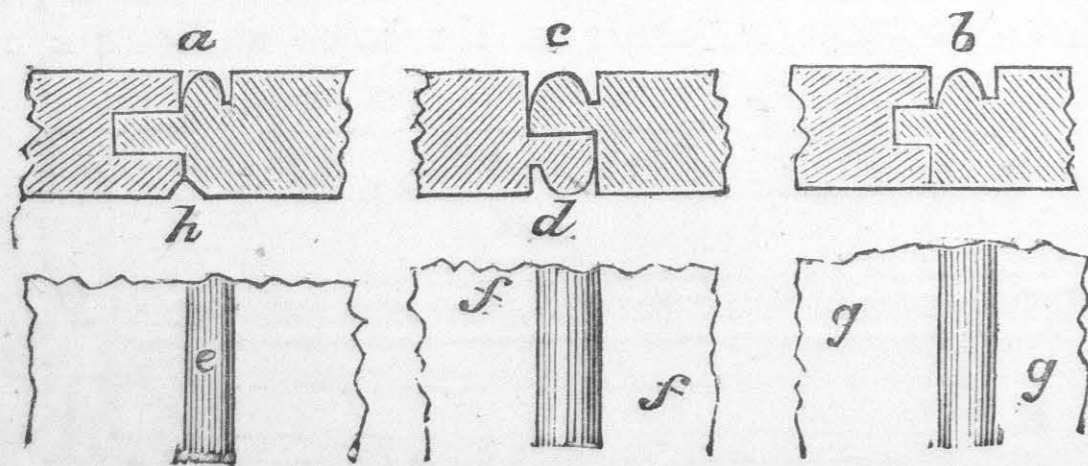
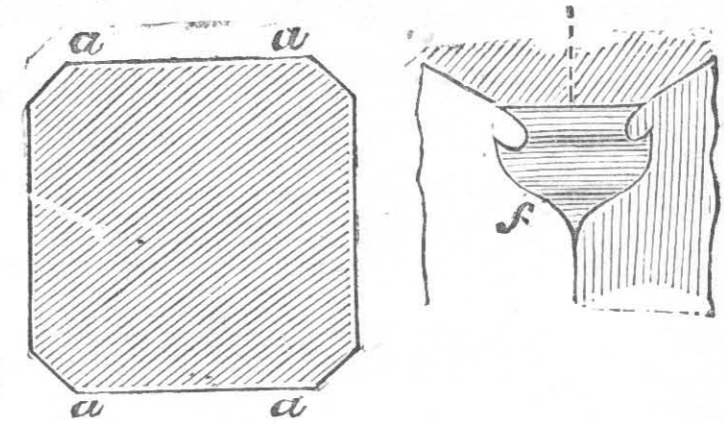

Fig. 109.

tion at *ee*. "Stop chamfers" are often made ornamental, especially in Gothic work. One method is shown at *f*; the dotted line indicates the sharp corner as continued.

Boards put together in the way we have now illustrated are further secured and kept together in various ways, some of which are now to be figured. In fig. 111, the method known as "ledging" is illustrated at *bb, cd* being the section.



When the boards, as *aaa*, fig. 112, are cross-grooved or ploughed in their ends, as at *b*, and held together by the piece *ccd*, which is feathered in its edge, they are said to be "clamped;" *d* being the "clamp."

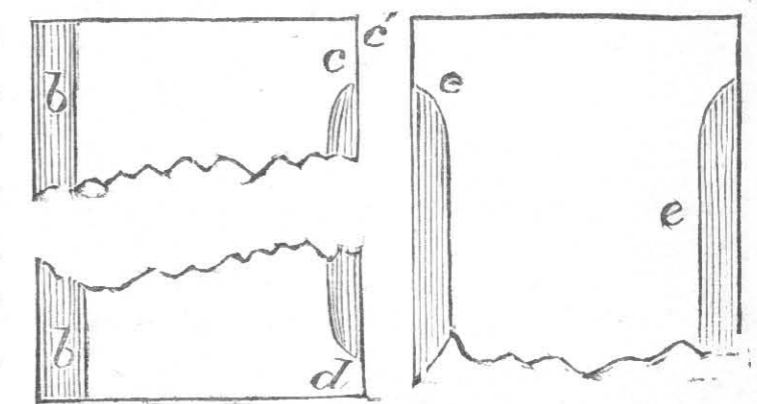

Fig. 110.

In place of the clamp being

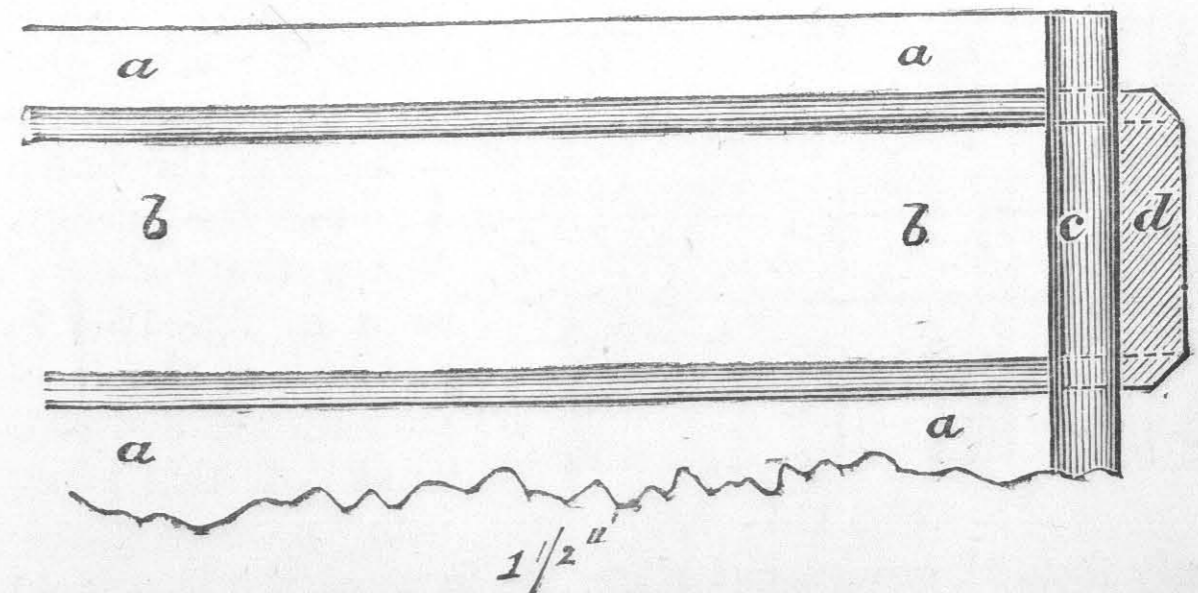
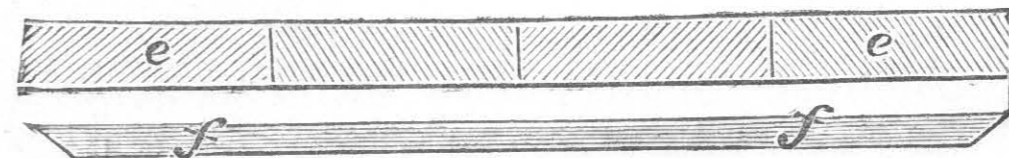

Fig. 111.

terminated at the ends, as at *e*, that is, made to reach

across the full breadth of the boards, *a a a*; the ends of the clamp and the last of the boards on each side

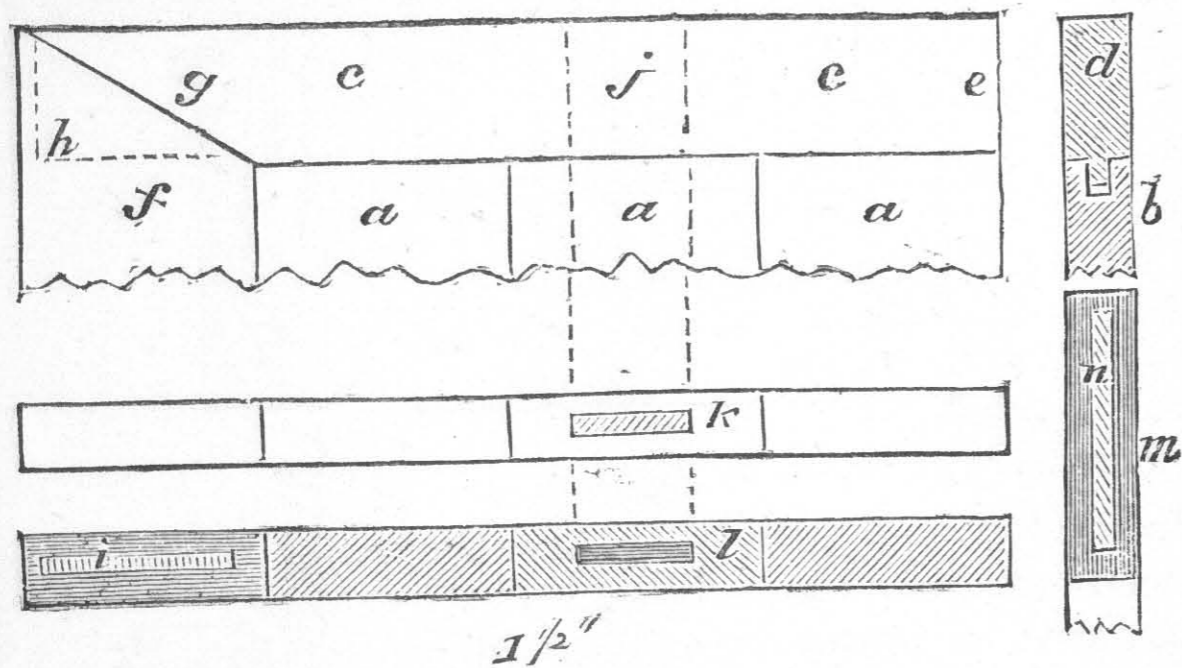

Fig. 112.

are mitre jointed, as at *g*; *f* being the last board at the edge. This joint may be further secured by a tenon at the end of *g*, as shown by the dotted line, *h*, going into the "mortise," as shown in the section. In some cases the boards, *a a*, are finished with a tenon, shown by the dotted lines, *j*, going into a mortise cut through clamp, *c*. This is shown in the plan at *k*, and in the section at *l*.

The face of the mitre joint at *g* is shown at *m-n* being the tenon *h*; *m*, the clamp. When the "clamp," as *a a*, fig. 113, is finished at the back with a dovetailed part, as at *b b*, this going into a correspond-

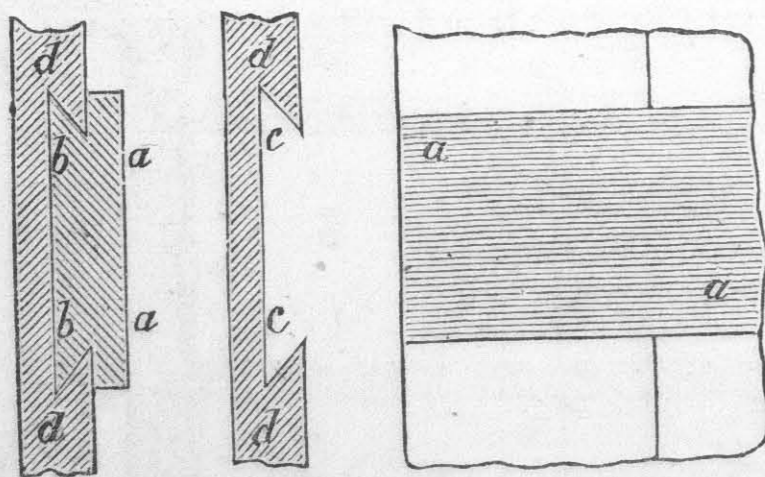

Fig. 113.

ingly formed groove cut along the faces of the boards to be joined together, the clamp is said to be a "mitre clamp," and the boards to be "mitre clamped." (See

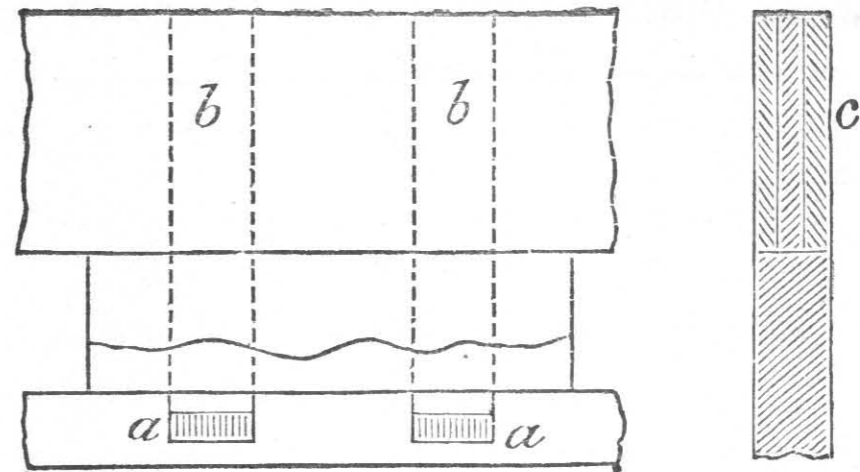

Fig. 114.

Advanced Course, Building Construction). Boards are framed together, as already partly illustrated, in the paragraphs treating of "Doors." In place of a single tenon and mortise, a double mortise and tenon is used, as at *a a*, *b b*, fig. 114. The tenons are sometimes wedged up; this prevents the tenon from being drawn out; as illustrated in fig. 115, where *a* is the tenon,

b b the wedges, shown in section at *c c*, the wedges, *d* the tenon. The tenon, in place of being single, as already shown, may be

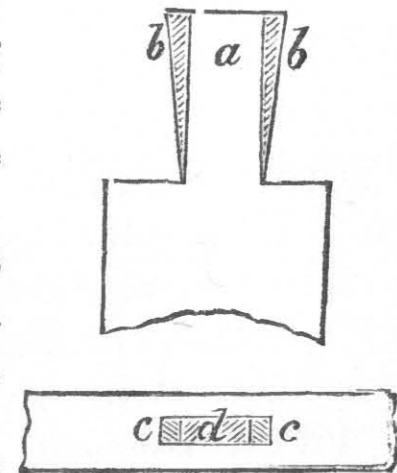

Fig. 115.

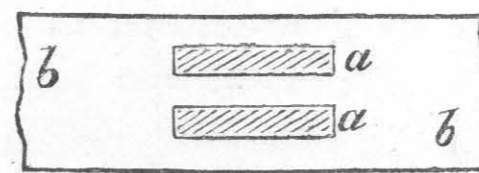

Fig. 116.

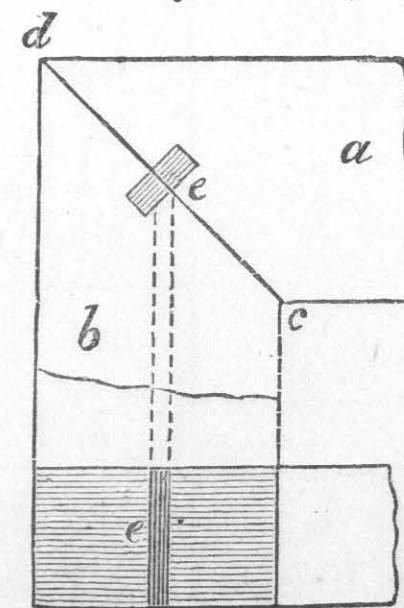

Fig. 117.

double—two mortises, as *a a*, fig. 116, being requisite in the thickness of the frame or style.

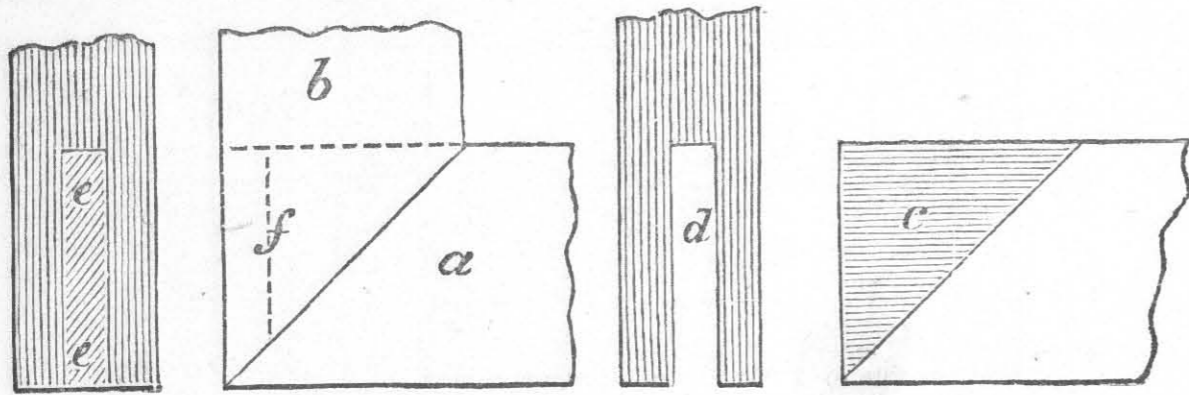

Fig. 118.

Pieces are joined at right angles by several methods, one of which is illustrated in fig. 117. Other methods will be found in the *Advanced Course of Building Construction*, in this series. In fig. 117 the pieces, as *a* and *b*, are simply

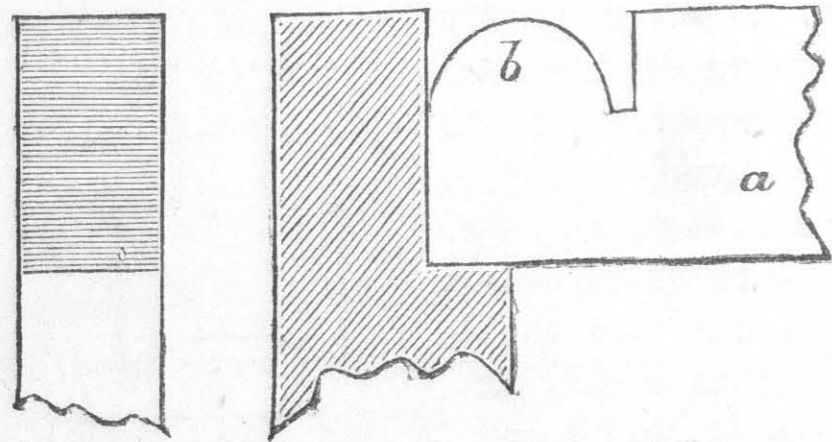

Fig. 119.

“mitred” at the angle of 45° on the line *c d*, the faces of the joint being made square, the two secured together by a nail, or a small “dowel,” or pin, as *e*, may be put in, as shown about the centre of the mitre line, *c d*; the lower diagram is plan of the lower piece, *b*, looking down vertically upon the face of joint, *c d*, this being indicated by the longitudinal shading, *e* being position of the dowel, *e*. Fig. 118 shows a method of joining pieces at right angles, used for the internal angle of skirting boards—the projecting piece, *a*, at the end of *b*, passing into a groove, cut on the edge

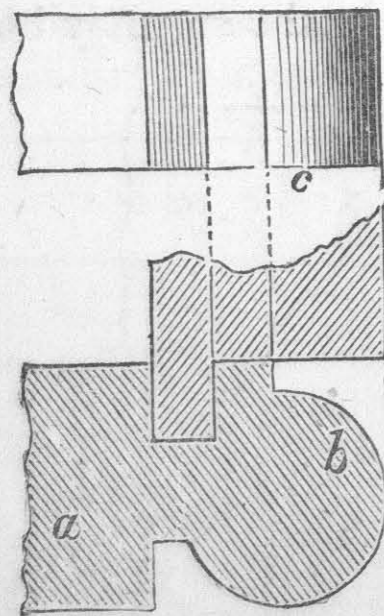

Fig. 120.

of the piece, *d*. Other methods, in which the mitre is rebated, or made with dowels or keys, will be found illustrated in the *Advanced Course*. Fig. 119 is a joint for two pieces at regular angles, on which the piece *a*

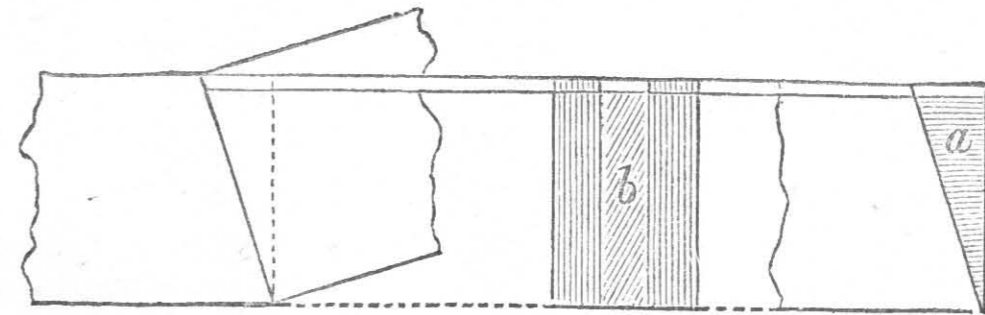

Fig. 121.

is finished with a single quirk bead. A joint of this kind is also made, in which the sharp corner of the two joining pieces is got rid of by terminating the piece *a* with a double quirked bead, as at *a b* in fig. 120. Fig. 121 is a joint in which one piece, as *a*, is at an angle to another piece, *b*, other than a right angle, the two being secured by a mortise and tenon, *b* and *a*. Fig. 122 illustrates another method. The various forms of joints of pieces at angles to each other are sometimes strengthened by pieces, called “blockings,” placed behind, these being glued or nailed to the pieces. Various forms of blockings, *a, a, a*, are illustrated in fig. 123, *b c* being the pieces joined at right angles to each other; and at *a*

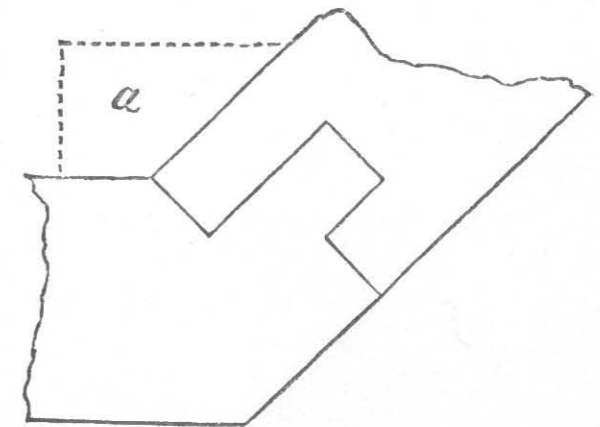

Fig. 122.

in fig 124.

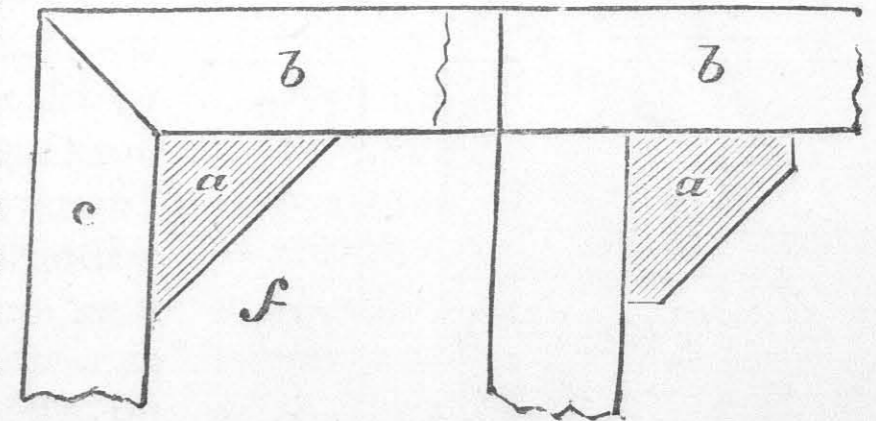

Fig. 123.

Dovetail joining is a method of joining pieces at right angles to each other by projecting pieces, which may

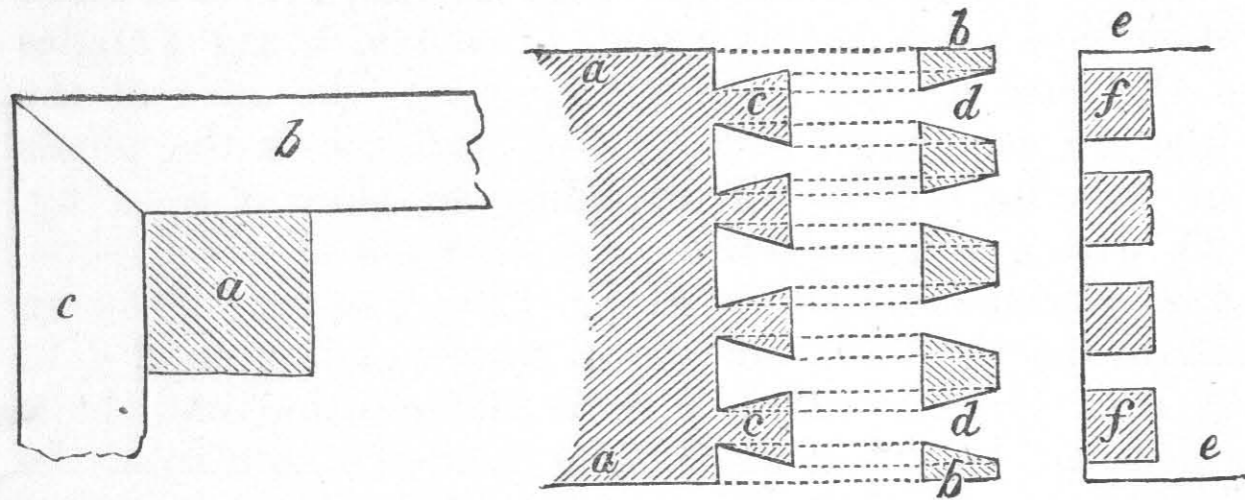

Fig. 124.

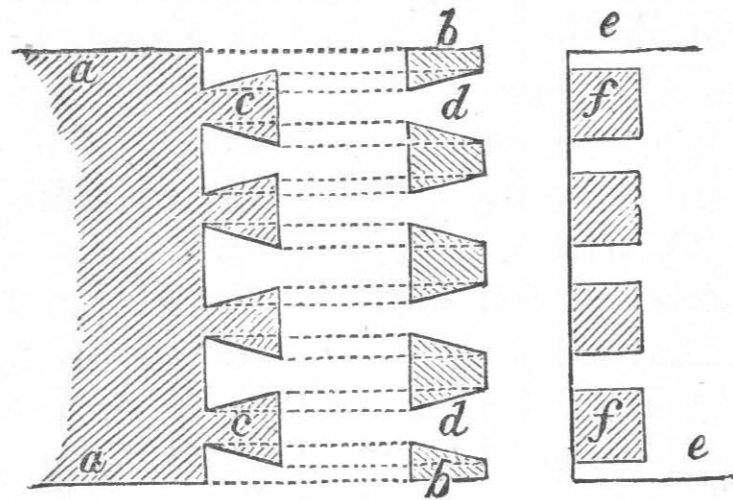

Fig. 125.

be called tenons, broader at one end than another;

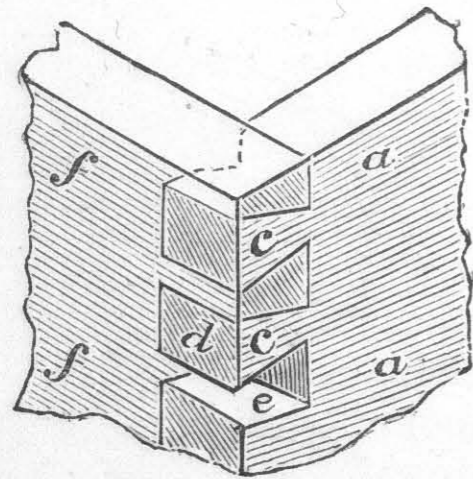

Fig. 126.



Fig. 127.

these passing into parts cut, of corresponding shape, in the edge of the others, and which may be called the mortises. In what is known as "common dovetailing," the joints are seen on both sides, as shown in fig. 126. In fig. 125, *a a* is the front surface of the piece to be joined, with a "common dovetail" joint, to the piece *b b*, of which the edge only is,

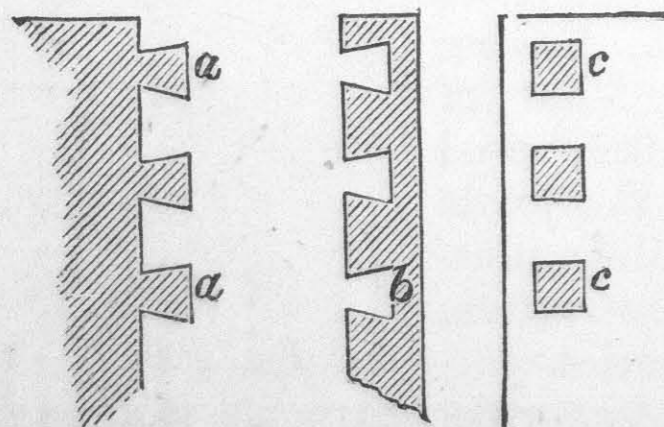

Fig. 128.

of course, seen in the drawing; *c c* are the expanding projecting pieces or tenons; these are passed into the parts, *d d*, cut out on the edge of *b b*; *e e* shows the return face of *b b*, this being, of course, at right angles to the face of the other piece, *a a*; the ends of the piece *c c* are shown at *f f*. Fig. 126 shows the pieces put together—*a a* corresponding to piece *a a* in fig. 125, with expanding tenons, *c c*, the ends of which show at *d*, corresponding to *f* in fig. 125; *e* in fig. 126 being one of the parts cut out of *f f*, corresponding to *d d* in fig. 125. In fig. 127, *a a* show the position and shape which the hole, *b b*, fig. 125, presents, as seen from the inside face of *b b* in that figure. In what is known as "lap dovetailing," the end, *d*, fig. 126, of expanding piece, *c*, is concealed, and only the flat sides are shown at one side; this is effected by shortening the expanding projection, as at *a a*, fig. 128, and cutting off the indentation of the other piece, so as not to go through the piece entirely, as in fig. 125, a solid piece, *b b*, being left. In fig. 128, *c c* shows the appearance of the only side at which the joint is seen; this is further illustrated in fig. 129, *a* showing one piece cut out completely as in common dovetailing, as in fig. 125; *b*, the expanding mortise cut short so as not to go through, leaving a piece, as at *c*. The kind of dovetailing known as "mitre," used for superior work where the joints are entirely concealed, will be illustrated in *Building Construction, Advanced Course*, in this series.

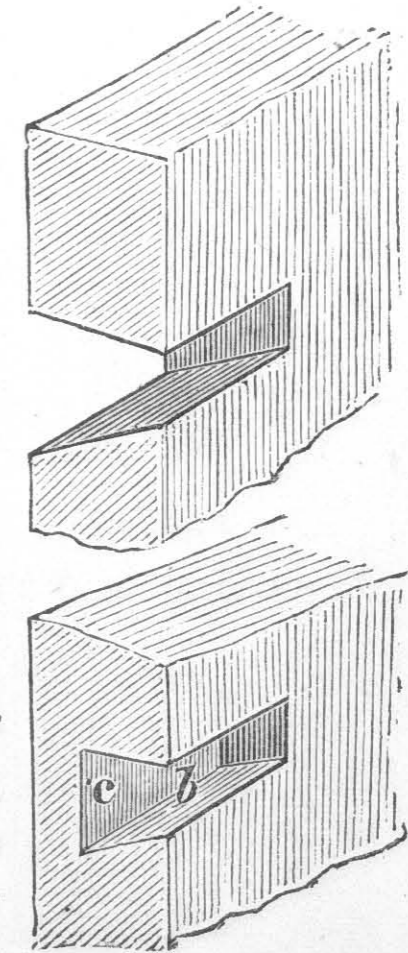
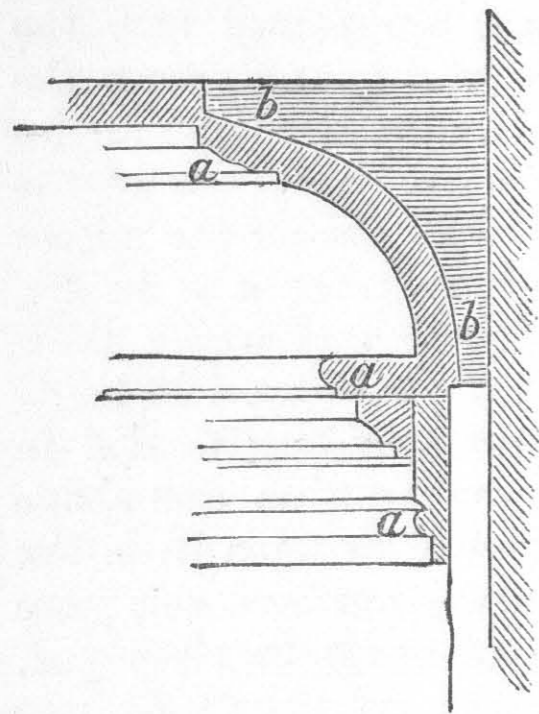

Fig. 129.

Brackets.—In fixing plaster cornices to rooms, as at *aaa*, fig. 130, the plaster is worked out on the outside of pieces of wood, as *b b*, the outer edges of which are cut

so as to follow roughly



the outline of moulding. The bracket for the cornice may be made with its outer edge cut to the several shapes of the part indicated, and may be built up of separate pieces of timber dowelled and jointed together, as in making wooden pillars; this and other methods of joining timber will be found in the *Advanced Course* named above. We have already shown how architraves are secured to grounds. Architraves are of two kinds—single and double.

In fig. 131 is illustrated a "single architrave." The mouldings are at one end only, the

Fig. 130.

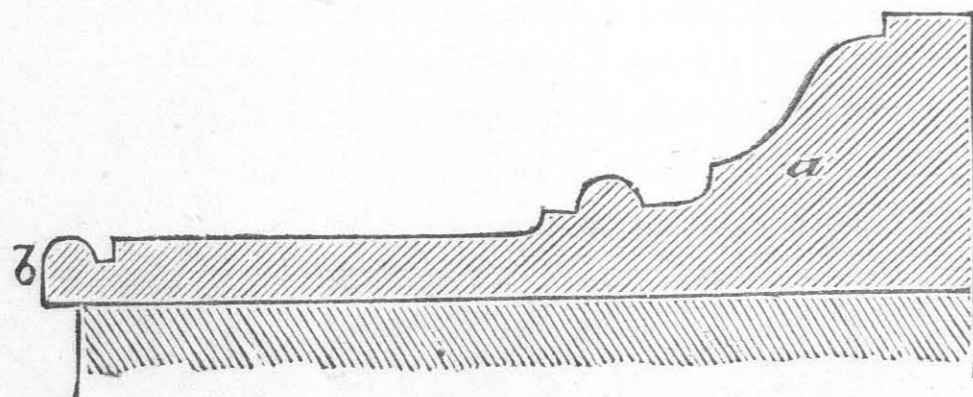

Fig. 131.

architrave being generally terminated with a quirked bead;

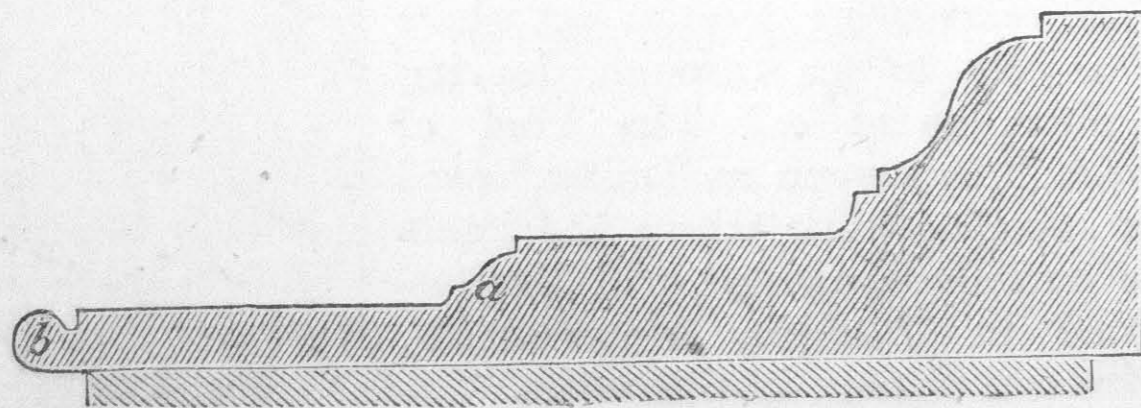

Fig. 132.

when a moulding is placed in the middle, as at *a* in fig. 132, the architrave is called a "double architrave."

CHAPTER IV.

WORK IN LEAD AND IRON.

In the *Advanced Course on Building Construction*, in this series, the reader will find remarks on the above materials—their nature and constructive peculiarities. We now proceed to point out briefly some of the more simple parts of construction in which they are employed, taking up lead first.

32. Lead flashings are the strips or bands of sheet lead, generally 8 to 9 inches in breadth, and weighing about 5 to 6 lbs. the square foot, which cover the joints made at the junction of the roofing boards, or slates to chimneys, &c. In fig. 133, we give a section at *a*, and part elevation at

b, of flashing to a chimneystalk; *bb* is the flashing or strip of lead; the joint, at *c*, is covered by the piece of sheet lead, *d*, the end, *e*, of which—2 inches in length

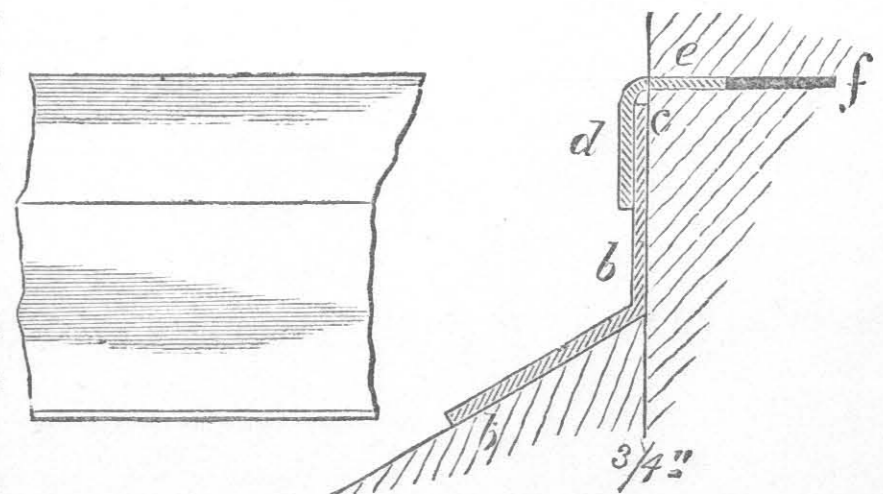

Fig. 133.

—is passed into the joint, *f*, of the brick-work, part of the mortar being scraped out to allow of *e* being inserted. Fig. 134 represents the ordinary mode of employing lead flashing for gutters at the back of a parapet wall. The edge, *a*, of the lead is inserted into the joint, *b*, of the brickwork for about 1 inch in width, the mortar being taken out for this distance between the

joins to admit of the lead being entered. It is then bent vertically downwards at *c*, against the wall, *d*, then returned horizontally, as at *e*, over the surface of the

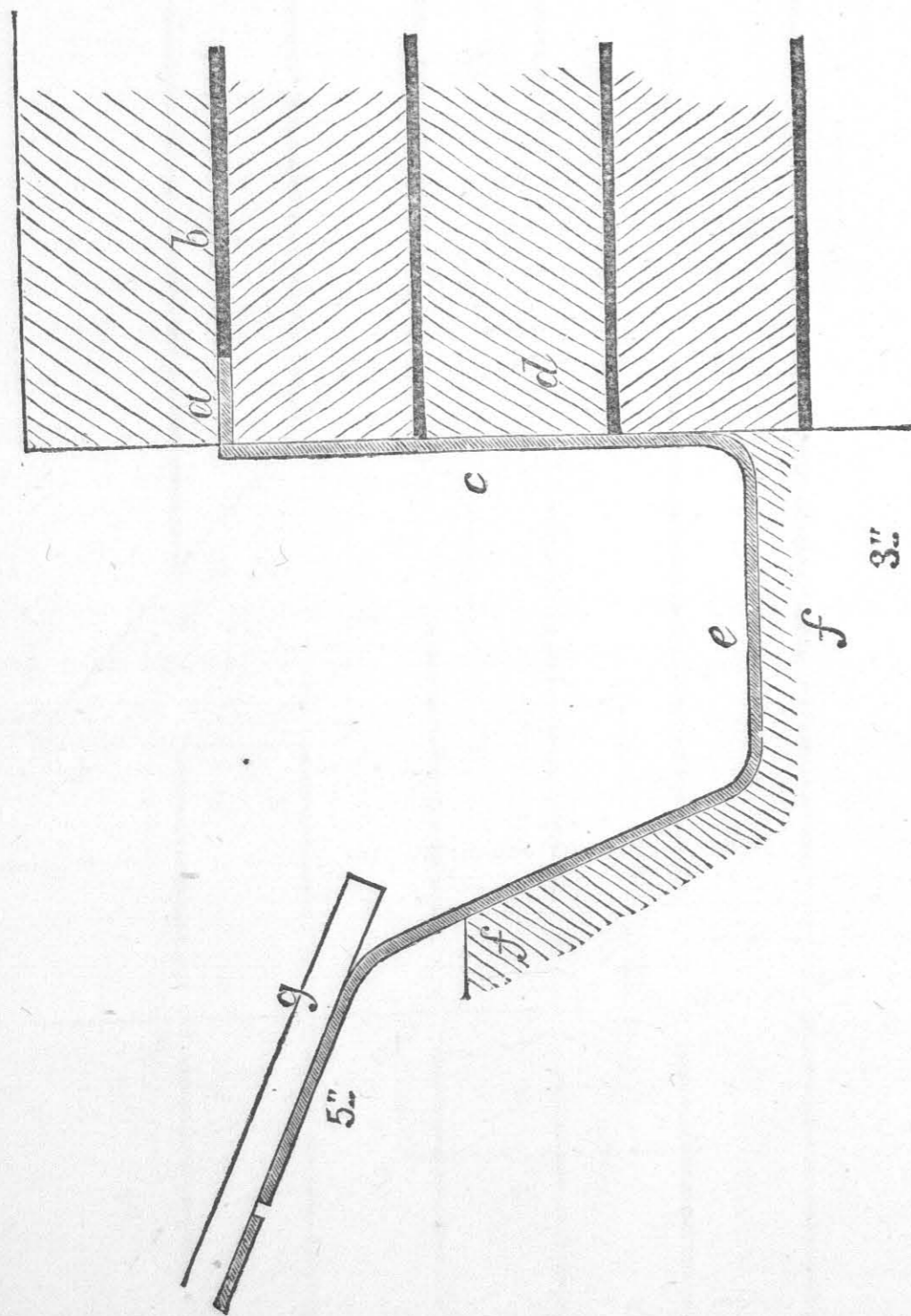

Fig. 134.

gutter, *f*, and up under the slates, tiles, or roof covering, at *g g*, some 5 or 7 inches. Fig. 4, Plate XV., illustrates another method of finishing the part at *a*, fig. 134. Fig 7, Plate XV., illustrates the gutter at the outer or parapet side of a flat roof; fig. 8 the

central gutter of the same; with method of making the lead junctions.

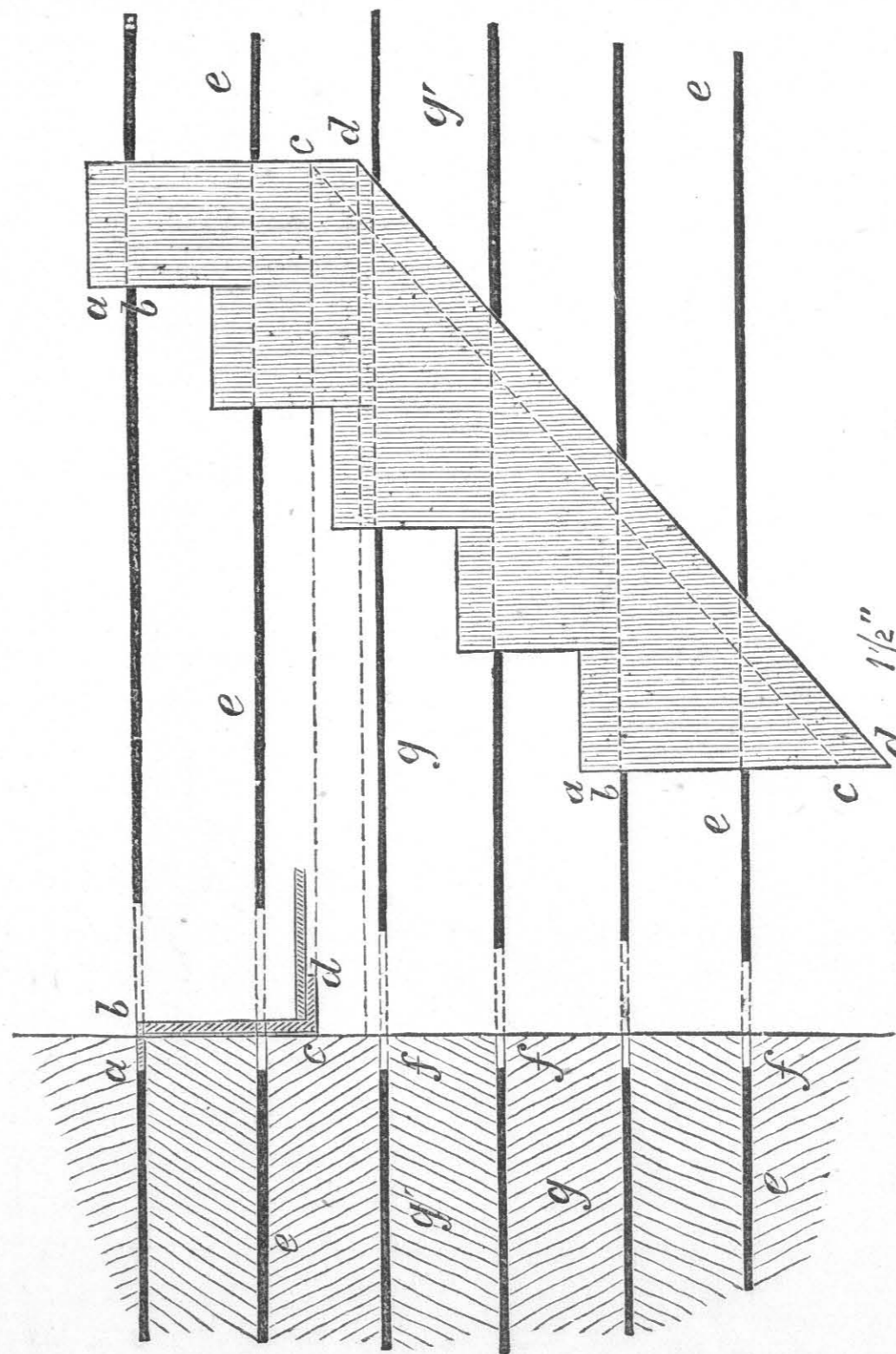

Fig. 135.

In the case of the junction of a roof surface with a parapet wall, or coping of the gable, the "flashing" is

required to be done with great care, so as to prevent the rain from insinuating itself to the work below. In the case supposed, the "flashing" is laid on the slope corresponding with that of the roof. "But, as it would not be convenient," says Pasley, "to groove the bricks for receiving the upper part of it in any other manner than by opening the joints, which are all horizontal, the lead is notched at top, in the form of steps, in the manner shown in fig. 135; 1 inch of each step, the upper part of it (*a b*), is then let into one joint of the successive courses

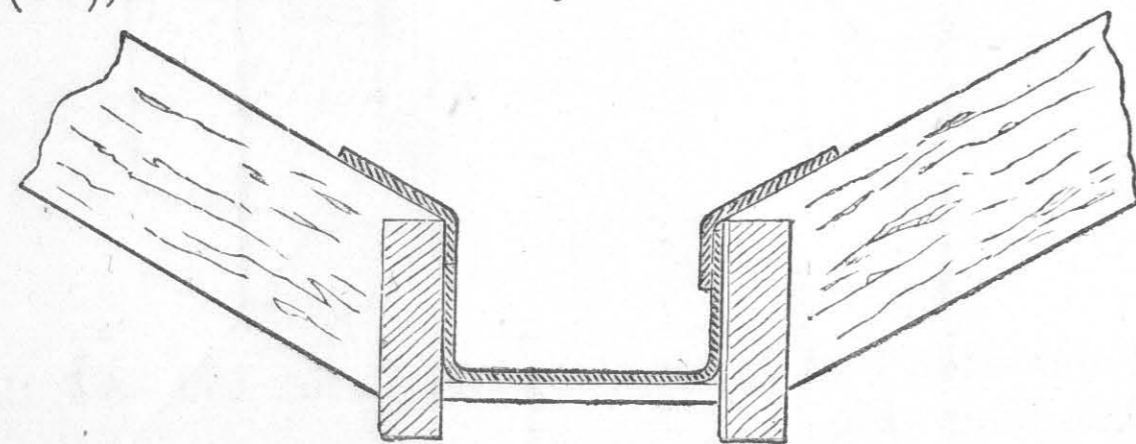

Fig. 136.

of brickwork, whilst the lower part of the flashing (*c d*), being bent at right angles, is introduced along the slope of the roof, and is either covered by, or covers the extreme course of slates or tiles which rest against the walls." Fig. 135 is an elevation of the lead flashing, but with the edges not bent; fig. 135, *a* in section shows the edges bent and inserted in the joints of the brickwork. In fig. 135, *e e* are the mortar joints, with the parts of *f* taken out to admit the lead; *g g*, the bricks. In fig. 135, *e e* are the mortar joints; *g'*, the bricks. In figs. 136 to 141, various modes of using lead flashings are illustrated, fig. 136 being that for a valley roof. Figs. 137 and 138 illustrate a good use of lead flashings for parapet walls; the lead being returned over the top, and

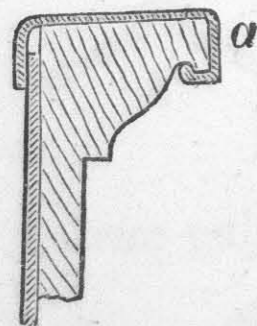

Fig. 137. terminating at the front, as shown at *a a*. It is good practice to have, in the case of parapets, a bed of cement

terminating at the front, as shown at *a a*. It is good practice to have, in the case of parapets, a bed of cement

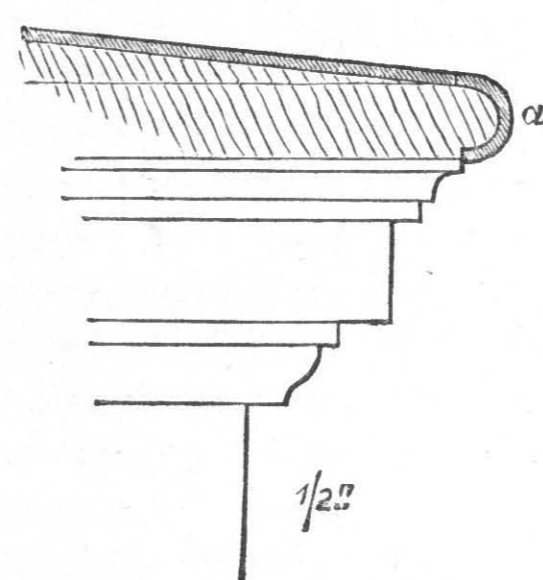

Fig. 138.

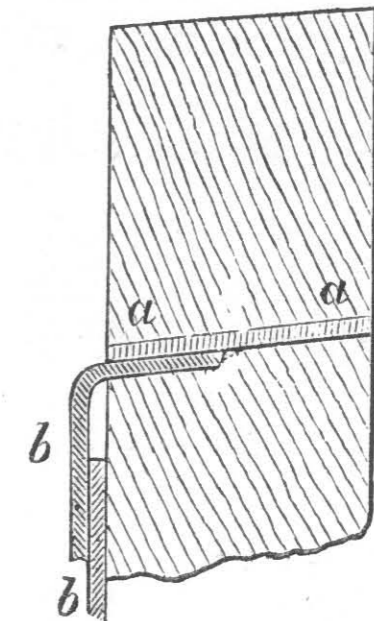

Fig. 139.

laid above the lead flashing, as at *a a* in fig. 139—*b b*, the lead flashing. Fig. 140 illustrates, in plan, *a*, and section, *b*, the flashing of a "hip rafter."

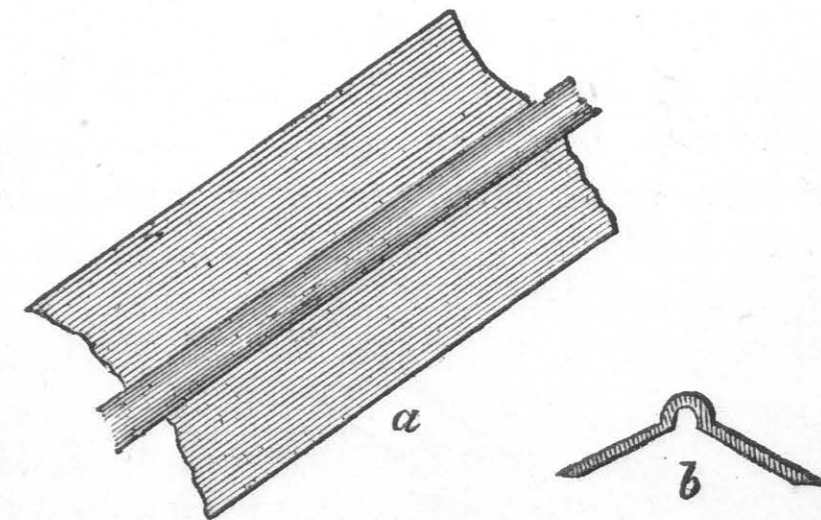

Fig. 140.

In fig. 141, the mode of covering joints in a "flat" is illustrated; *a*, a wood "roll," two inches deep, is secured to *b*, and the lead joint formed as shown; the part, *c*, being carried up the right hand side of the roll, and terminated by the point at *d*; the part, *e*, is covered over this, and terminated at the drip, *f*. Fig. 3, Plate XV., illustrates another form of "roll." The current or "fall" to flats should

Fig. 141. The current or "fall" to flats should

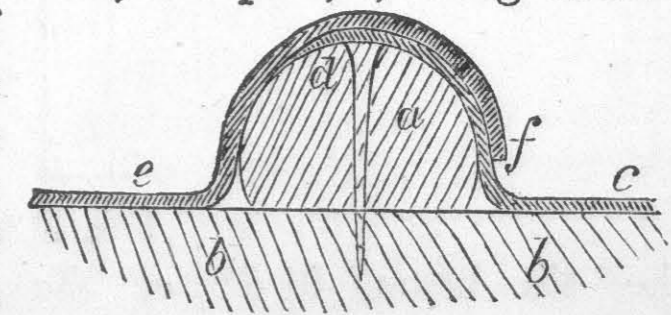

Fig. 141.

be some 3 inches; for gutters, 2 inches to every 10 feet. The finishing of roofs at the ridge is carried out in various ways, each with a ridge roll and lead flashing, similar to fig. 141; or by earthenware or slate ridges, more or less ornamented.

33. Iron Straps and Bolts.—In binding and securing together the members of timber structures, as roofs, partitions, &c., &c., wrought-iron bolts and straps are used.

In one or more of the figures already given these appliances are illustrated. We now propose to give a few more illustrations of their use.

In fig. 142 we give a method of securing together and of strengthening the joint at the foot of a principal rafter, *a*, where it joins

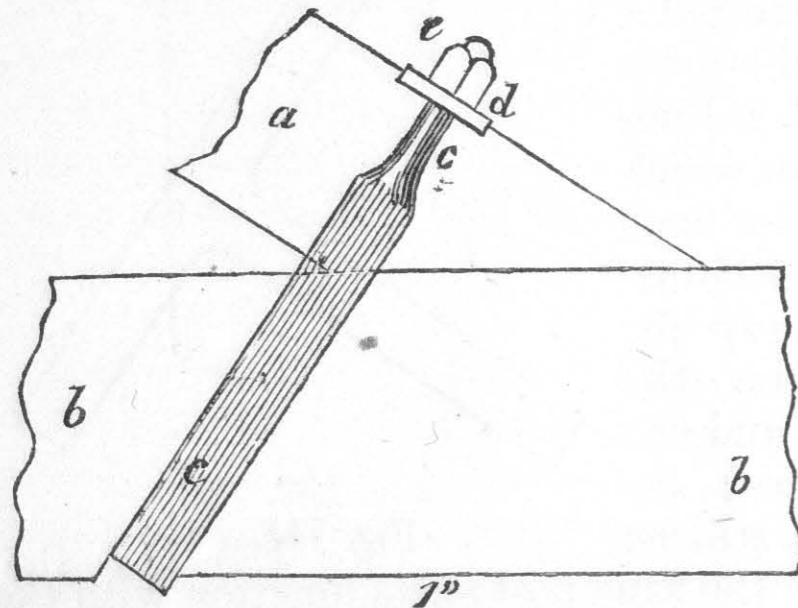

Fig. 142.

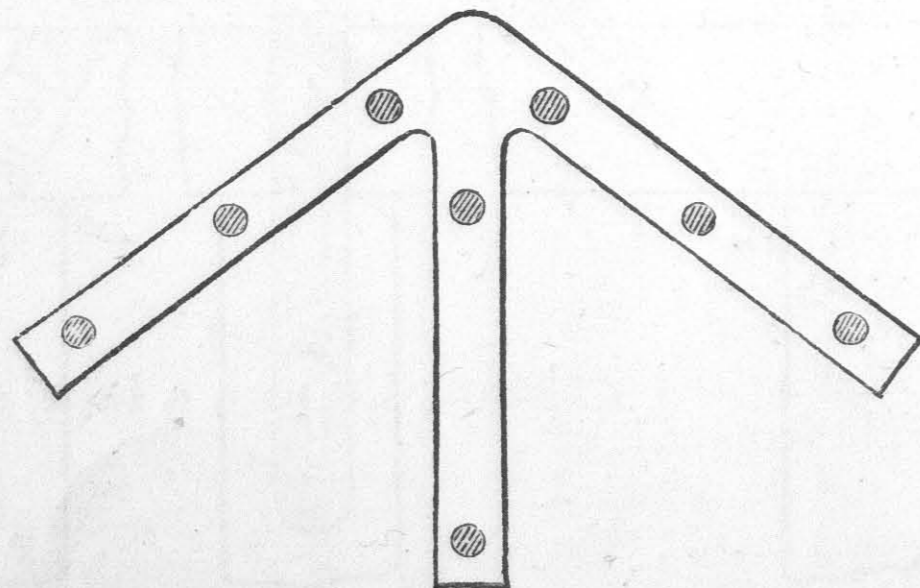

Fig. 143.

the tie beam, *b b*; *c*, the strap of wrought iron; the neck, *c*, is rounded to form a bolt which passes through the butting plate, *d*, and is secured by the

nut, *e*. Bolts are sometimes used to connect parts. Fig. 6, Plate XV., illustrates two other methods of securing the feet of rafters with the beams, *a* being a strap with key; *b, c*, a bolt and nut; *d* illustrates the use of a bearing-plate at end of bolt, *c*.

In Chapter Second we have illustrated a method of forming the junction of the foot of a king post with tie beam, in which the strap is secured by keys and cottars. Fig. 143 illustrates a form of strap for the junction between the head of a king post and the two principal rafters; reversed in position, it will be a strap for the foot of the king post at its junction with the two braces or struts. Fig. 144 illustrates a form of strap at the junction of the upper end of a brace or strut with the principal rafter. In fig. 145, the head and

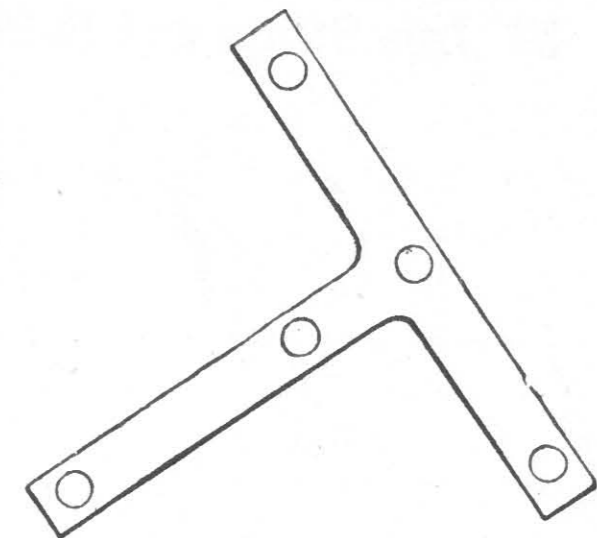

Fig. 144.

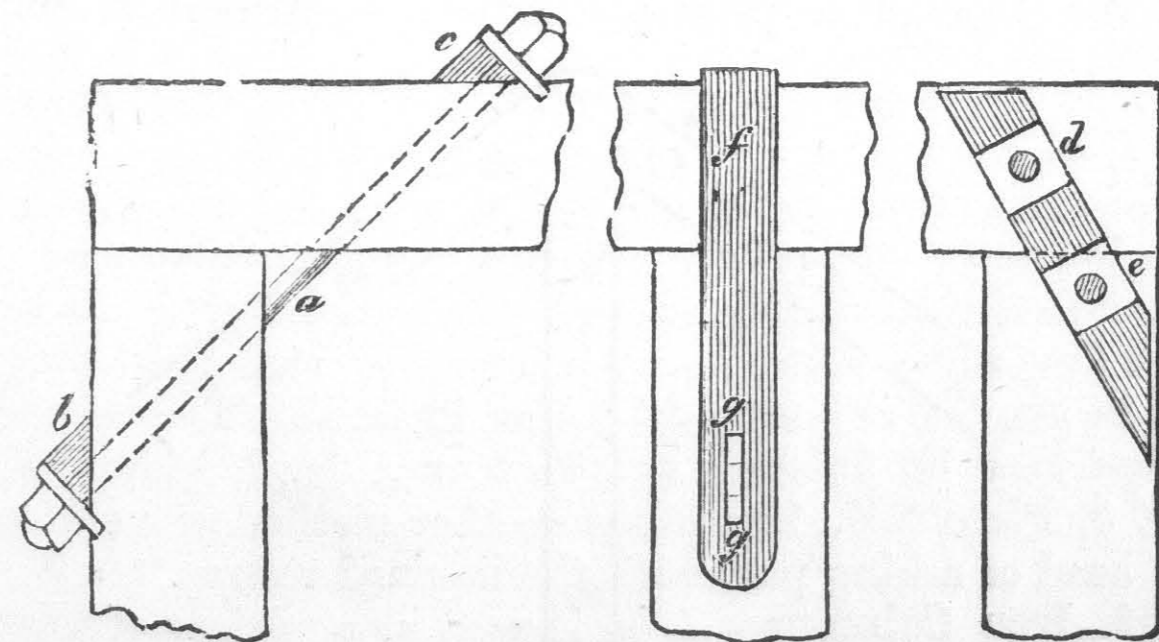

Fig. 145.

sill of a framed partition are shown united and strengthened by a bolt, *a*, the ends of which are secured by nuts bearing upon small iron butting pieces, *b c*. The

use of these prevents the necessity to cut deeply into the timber to get the bearing plates of the nut set at right angles to the bolt. The pieces may be united and strengthened by plates, one on each side, as shown at *e*, secured by bolts and nuts. The head and the post of a partition may be united and strengthened by a strap, *f*, fig. 145, secured by key and cottar, as at *g g*. In fig. 1, Plate XV., we give a sketch of a strap for securing the foot of a king post with a tie-beam; this passes over the tie-beam, which slips into the part *d d*, the bolt, *a*, being passed through the hole in the eye, *b*, and through a hole bored in the foot of the king post. In fig. 2, Plate XV., *a b c d* is a strap or plate—two being used, one at each side—used to connect and secure together the foot of a king post with the ends of the two braces or struts; the wing, *a*, being secured by a bolt and nut to the left-hand brace or strut; the wing, *c*, to the right hand strut; the central part, *b*, to the king post; and the lower part, *d*, to the tie-beam. Or in place of being used as single straps or plates—one at each side—the whole may be formed into a strap or “stirrup plate,” as shown by the extended dotted lines at *f* and *e*; the upper parts at *f* being edge views of the two separate parts, *a b*, *c d*. Fig. 2, Plate XV., also illustrates a strap or plate, at *g h i*, to connect a collar beam (horizontal)—this being at *h*—with a rafter (inclined), *g* and *i* being the bolt or pin holes for the rafter. A strap, suitable to secure a queen-post straining beam and principal rafter, is shown at *k l m*, same figure; *n n* being edge view; the part, *l k*, in practice is horizontal; *k m*, inclined. The ends of straps may be finished, as at *a b* or *g*, fig. 2, Plate XV. Fig. 5, Plate XV., illustrates another method of securing the head of a king post with the inclined rafters.

34. Iron Columns.—Iron is used in a variety of ways in combination with wood, as in beams, roofs, &c., &c. In fig. 6, Plate XVI., a form of cap of a cast-iron column to receive the timber sandwiched beams, *a b*, is illustrated. The beams rest in, or are embraced by the box,

c c, of which the side is shown at *d*, this being strengthened by the curved wing, *e e f*; the beams are secured to the box by two bolts and nuts, as shown; the cap of column or pillar is at *g g*, *c c* being cast to this so as to form one piece; *b b*, the base; there are several methods of securing the base to the ground. Others will be illustrated in the *Advanced Course of Building Construction*. In the one here shown, the base, *b*, is provided with a circular projecting part, *i i*; this is passed into a circular hole cut in the stone base, *j j*. In some cases the square plinth is partly let into the surface of stone

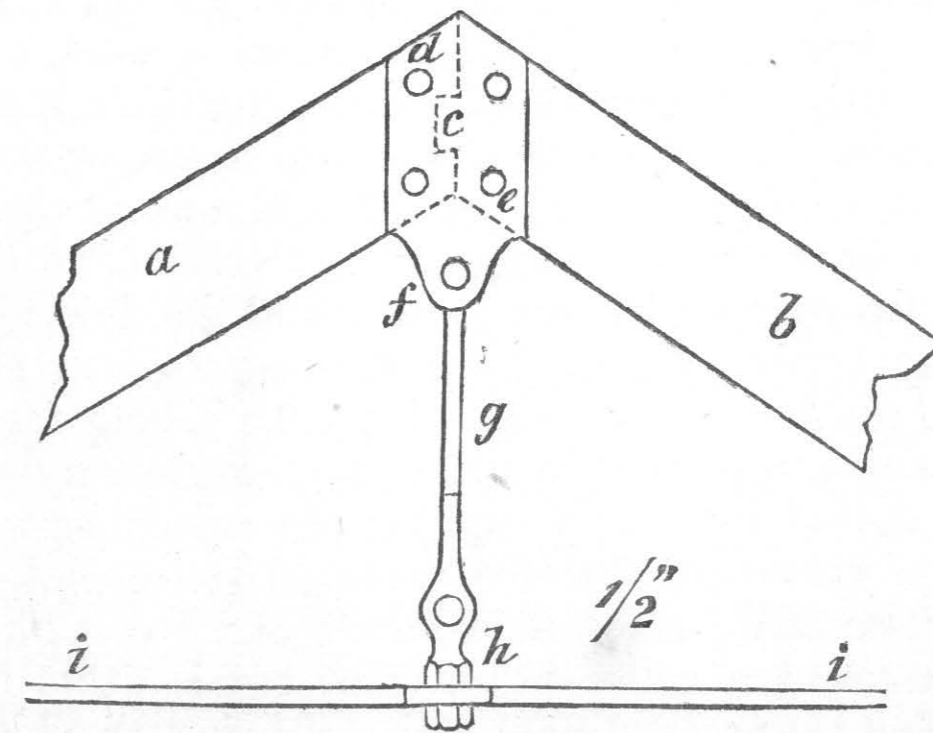

Fig. 146.

sill or base, *j j*, as shown by the dotted lines in fig. 6, Plate XVI.

35. Iron and Timber Roofs.—Timber roofs are sometimes constructed with certain members of the combination formed of wrought iron, as the tie rods and king bolts, for which parts, being in tension,* wrought iron is so well adapted—cast iron being used for rafter boxes, clips, &c., &c. In figs. 146 and 147 we give parts of a timber roof of this kind, adapted to a 30 to 34-foot span—

* For a description of the strains to which materials are subjected, see *Advanced Course of Building Construction*.

the truss assuming the form as shown in fig. 148, but without the struts or braces, *b c*. Fig. 146 is the assemblage at junction of the rafters, *a b*, the ends of these being let into each other by the notch at *c*; the

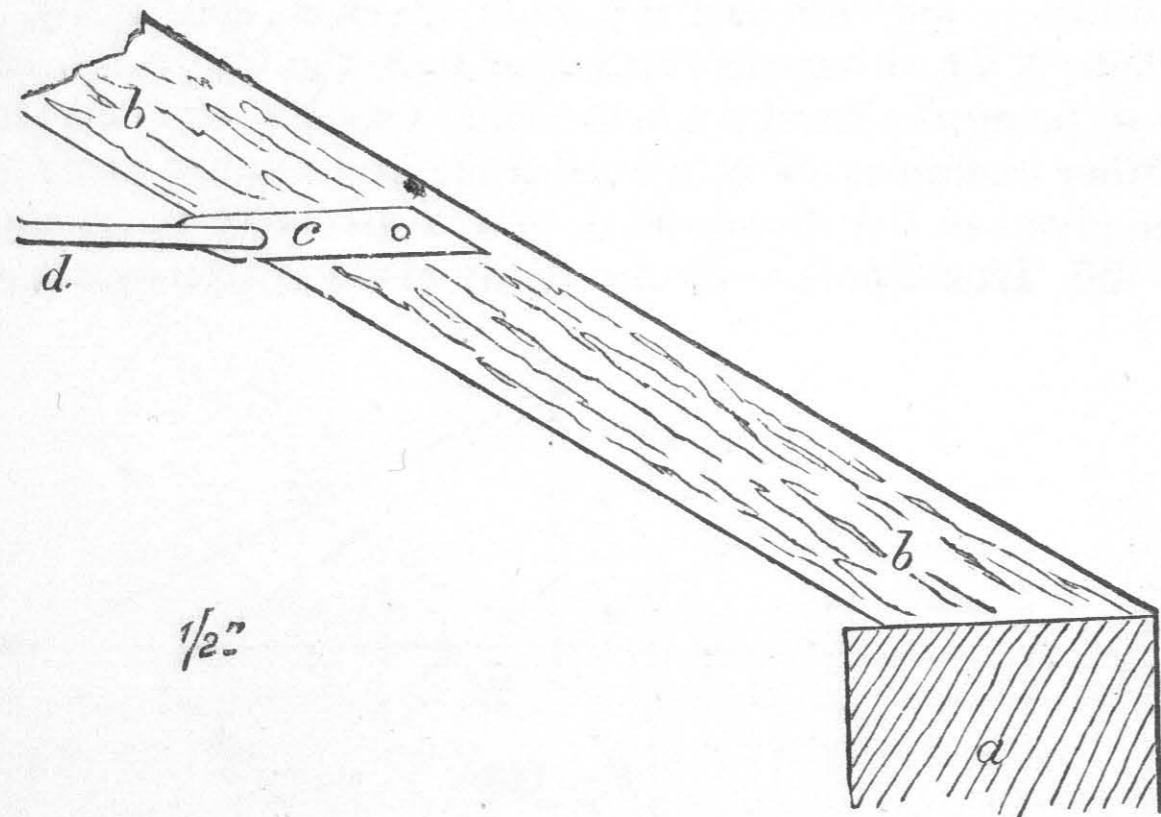

Fig. 147.

ends are secured to the cast-iron clip, *d e*, by the bolts and nuts, as shown—the lower end, *f*, being rounded off to admit of the end of the king bolt being jointed to it; the lower end of this being secured to the central part, *h*, of the iron tie-rod, *i i*. Fig. 147 is the assemblage of the truss at the foot of the rafters; *a*, the wall; *b*, the rafter; *c*, the clip of tie rod, *d*, this being bolted to the rafter. In fig. 1, Plate XVI., we give the detail of rafter box, *d e*; in fig. 146, in front elevation, *a a*, and in side view, at *b b*, fig. 2, *c d*, the clip, between the jaws of which the eye, *a*, of the king bolt, *b*, fig. 3, Plate XVI., is passed and secured by bolt and nut. The lower part, *c*, of the king bolt, *b*, is eyed out at *i c*, and terminated by a round bolt, *d*, which passes through the eye, *e*, of the enlarged central part, *f*, of the tie rod, *g g*, and secured by the nuts, *h h*; *i i* is a side view of the parts, *a b c*. In fig. 4, the en-

larged detail of clip, *c*, fig. 133, is shown *a a*, being the side view; *b b*, the plan; and *c c*, the end view of the whole when put together. A lateral tie is made between the trusses by a bolt or iron rod passing through the eye, *c*, fig. 3, Plate XVI., reaching from end to end of the building, and secured by nuts at each end. Fig. 4, Plate XVI., illustrates on larger scale the clip, *c*, fig. 147; *a a*, being the front; *b b*, the edge view; *c*, the end view. Other examples of combined iron and timber roofs will be given in the *Advanced Course, Building Construction*.

36. Iron Roofs.—Roofs wholly made of iron—cast and

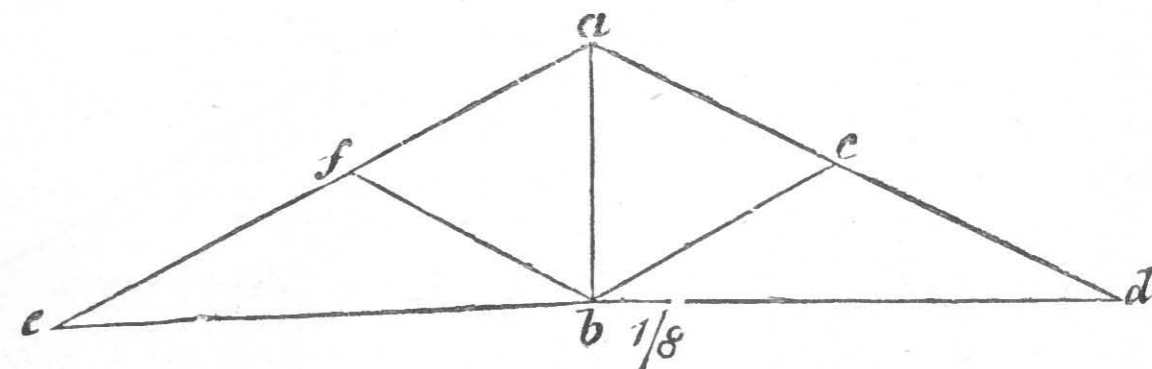

Fig. 148.

wrought—are now largely used. Fig. 148 illustrates a skeleton truss of an iron roof adapted to small spans

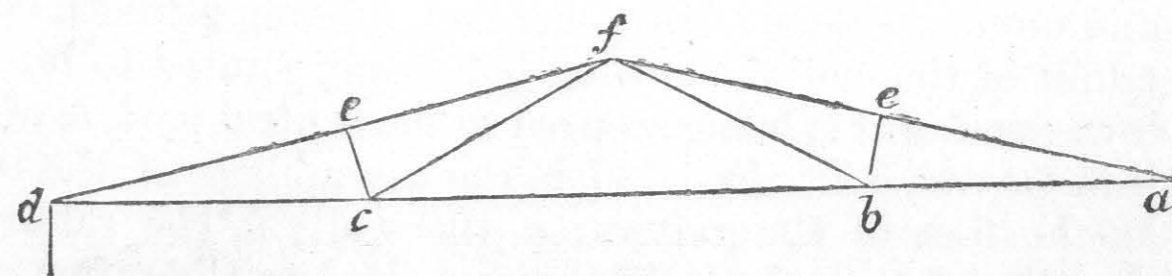

Fig. 149.

from 18 up to 25 feet; fig. 149 being another form for small spans; and fig. 150 for large spans from 30 to 40 feet. In Plate XVII. we illustrate the details, drawn to a scale of 3 inches to the foot on one fourth full size. In fig. 1 we give detail of assemblage of parts at junction of the foot of king bolt, *a b*, of which fig. 148 is the skeleton truss, with the tie bolt,

a b. This tie bolt is made in two parts, each of which is terminated towards centre or king bolt part of the roof, with eyes, *a b*, fig. 1, Plate XVII. View of upper face of their termination is shown at *a b*, and section at *e*, in fig. 3, Plate XVII. The ends, *a b*, fig. 1, Plate XVII., of the two parts of tie bolt are secured together by two wrought-iron plates, *c c*, *d d*, one of which is shown in plan in fig. 5, and in section at fig. 6, Plate XVII.—the whole being secured together by bolts and nuts, as shown at *e e*, *f f*; but before these are put in, the ends of the struts or braces, *g h*—corresponding to *a b c*, fig. 148—are put in place, the ends being provided with bolt holes. The plates, *c c*, *d d*, are provided with a central bolt hole, through which the lower end, *i*,

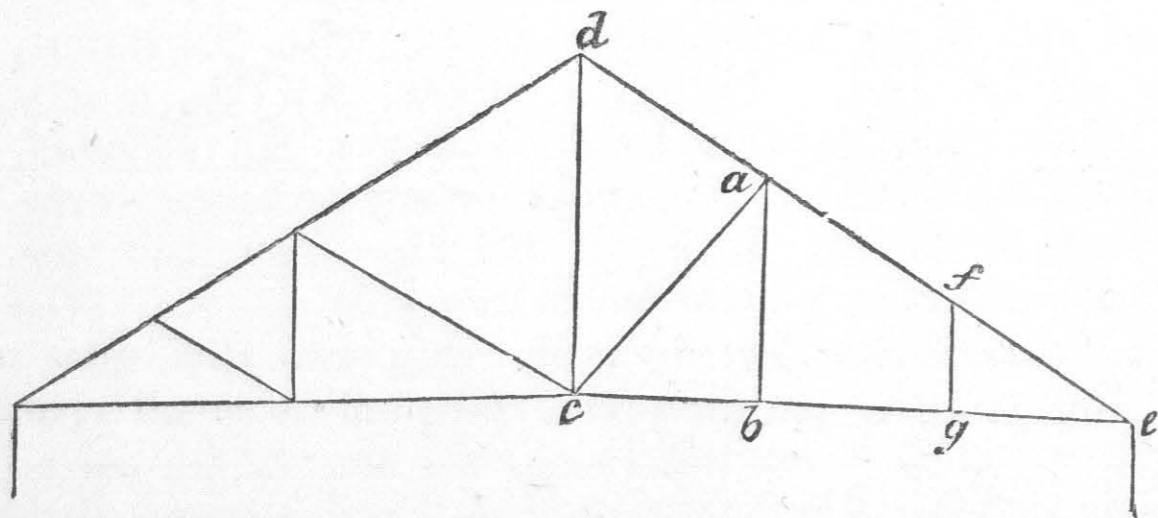

Fig. 150.

of king bolt; fig. 1, Plate XVII., is passed, being secured by the nuts *k l*. Fig. 2 is plan of fig. 1 from upper side. In fig. 7, Plate XVII., is given front elevation; and in fig. 8, side, and in fig. 9, plan of the under side of the rafter box, at the point where the rafter, *a d*, joins with the upper end of king bolt, *b a*, fig. 148. The rafter box, *a a*, is made of cast iron. The end of the king bolt, *b*, passes into an aperture made in the box, *a a*, and is secured by a key passing through a slot made in the sides of the box, and through the head of king bolt. The upper part of box is made, as at *d*, to receive the lower edge of the ridge piece or board.

The ends of the rafters are shown at *e e—f f*, on plan and side elevation, being the slots made in box, into which the ends are slipt, and which are generally secured by bolts and nuts, or by rivets. In fig. 10, we illustrate the form of rafter box, with junction of tie bolt, with same at the foot of rafter, *a d*, fig. 148; *a a* is the box of cast iron, in side elevation; in front elevation, in fig. 11, secured to the wall by the bolt *b*, leaded to the wall and nuts, *c c*. The rafter, *d*, fig. 10, is passed into the slot *b*, fig. 11, made in the box to receive it, and secured by the bolt which passes through the bolt hole *e*, fig. 10, this being fastened by the nuts *e e*, fig. 11. The end of the tie bolt, *f*, fig. 10, is eyed out, and passed into a slot, *f*, fig. 11, made in the box, and secured by bolt and nut, not shown in the drawing. Fig. 1, Plate XVIII., shows detail of the junction of end of the braces or struts, *b c*, with the rafters, or *a d*, fig. 148. In fig. 1, Plate XVIII., *a a* is the rafter corresponding to the rafter *e*, fig. 7, or *d*, fig. 10, Plate XVIII.; *b b*, end of strut or brace, corresponding to *h*, fig. 1, Plate XVII. The two are secured together by plates, one on each side, as *c c*, and the whole fastened together by bolts and nuts, *d d*, which pass through the plates, and rafter, and struts. The section in fig. 2 is on the line *a b*; fig. 3, is end or vertical section. The letters on figs. 2 and 3, corresponding to those in fig. 1. Fig. 4, Plate XVIII., are different views of the binding plates, *c c*, fig. 1. For a roof, the truss of which is as in fig. 149, the part at *a* will be almost precisely as illustrated in figs. 10 and 11, Plate XVII.—the part at *f*, fig. 149, somewhat similar to fig. 7, Plate XVIII.; but the junction of the ends of the rods, *b f*, fig. 149, with the rafter box, will be as illustrated in fig. 7, Plate XVIII. The junction of the strut, *b e*, fig. 149, with the rafter and the tie-bolt will be as in fig. 151—*a a* in this, being the rafter; *b b*, the cast-iron brace or strut, bolted to the rafter; the latter passing into a recess made at the head of the strut, *b*. The lower end of the strut is provided with a snug, to

which the ends of the rod, *c c*, are bolted, as also the end of the rod, *d*, corresponding to *b f*, fig. 150. In fig. 8, Plate XVIII., we give the front elevation, showing the junction of the upper ends of rafters of the truss to the right hand of fig. 150, at point *d*, with the upper end of tie bolt, *c d*. In this arrangement, the cast-iron rafter box, as shown in fig. 7, Plate XVII., is dispensed with, and the rafters, *a a*, *b b*, fig. 8, Plate XVIII., are secured together by two plates of wrought iron, one on each side, as, *c c c c*, the whole

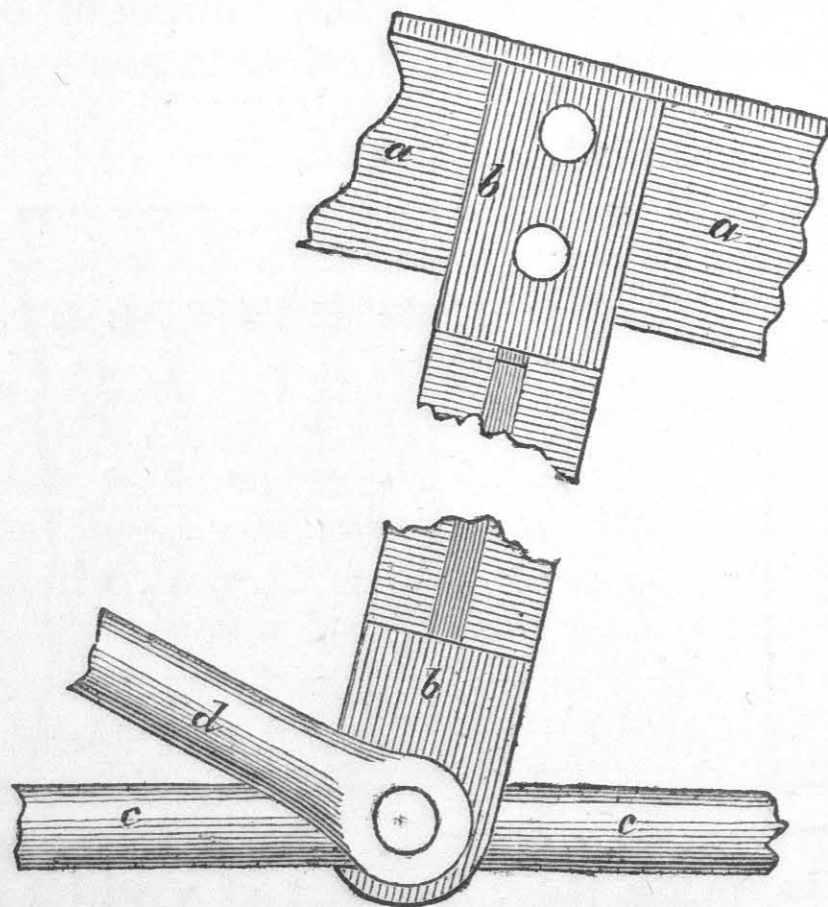

Fig. 151.

being bolted together — the ends of the rafters butting together with a plain or butt joint. The tie bolt, *d d*, is eyed out at its upper extremity, and embraces the two plates and the rafter, as shown in the section in fig. 5, Plate XIX. The ridge pole, or piece, *e e*, fig. 8, Plate XVIII., is notched into the block of timber, *f f*, secured between the angle irons rivetted to the flange of the rafter; *h h*, the roofing boards. The rafter box at foot of rafters is shown in elevation at fig. 6, Plate XIX; *a a*, the wall; *b b*, the cast-iron rafter box, provided with a recess in front to receive the end of rafter, *c c*, and which is secured by a bolt passing through the bolt hole, *d*; *e*, the end of the clip of tie bolt, the eye of which is secured by a bolt passing through the bolt hole, *f*. A

sectional plan of this in its full length (fig. 6, Plate XIX., being too small to admit of its being given there), is given in fig. 6, Plate XVIII.; a side elevation in fig. 5. In fig. 6, *a a* is the end of the bolt; this is embraced by the clip, *b b* (*b b*, fig. 5, in side elevation), which is secured to the rafter, *c c*, by the pin or bolt, *d*, passing through the bolt hole, *f*, fig. 6, Plate XIX.; this pin or bolt is kept in place by the split pins, *e e*; *f* is part of the rafter box corresponding to *b b*, fig. 6, Plate XIX., secured by the bolt, *g*, passing through the bolt hole, *d*, fig. 6, Plate XIX. In fig. 6, Plate XVIII., filling-in or bolster pieces, *h h*, are placed at side of rafter to make up

the space; the clip, *b b*, and end of tie rod, *a*, fig. 6, Plate XVIII., are secured together by the "gibs," *i i*, *j j*, and cottar, *k k*; an inside edge view of one of the gibs being shown at fig. 7, Plate XVIII. In fig. 2, Plate XIX., we give a side elevation at *a*, fig. 150, showing method of joining the upper end of strut or brace, *c a*, with rafter, *d e*, and queen bolt, *a b*. In fig. 2, Plate XIX., *a a* is rafter; *b*, end of strut, secured to the rafter by plates at each side, one of which is shown at *c c*; the upper end of queen bolt, *d d*, is secured to the plate, *c*, and rafter, *a*,

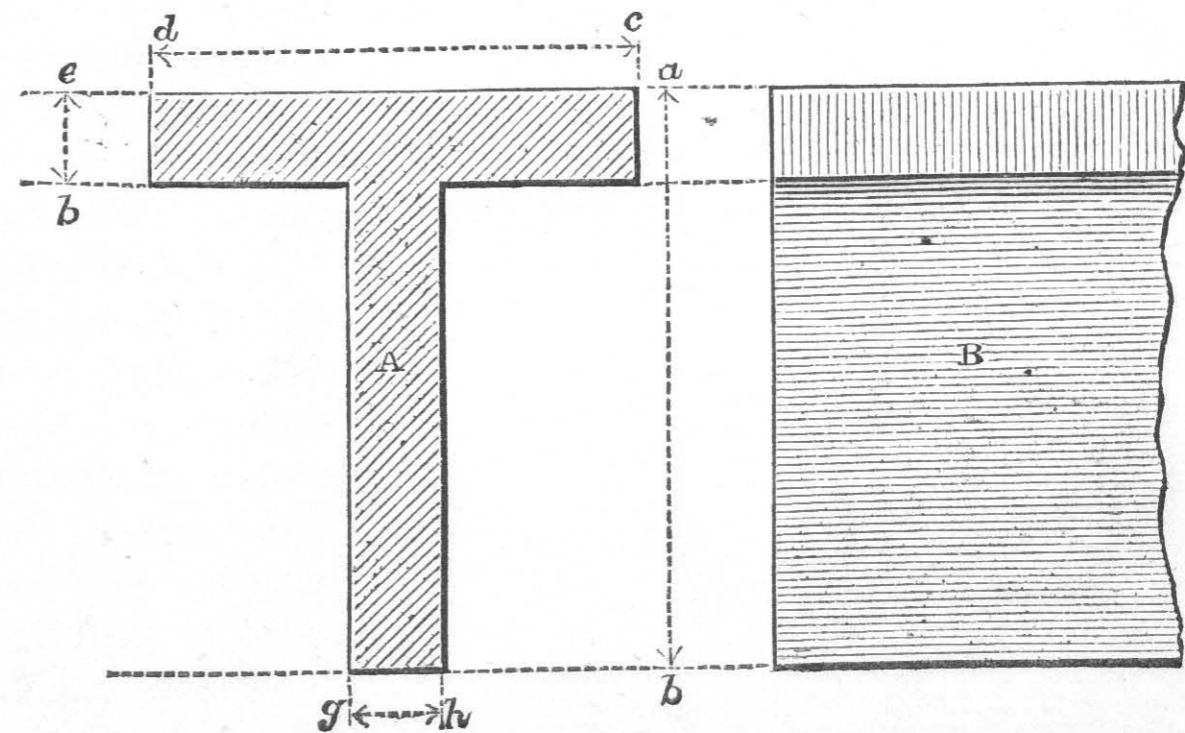

Fig. 152.

the space; the clip, *b b*, and end of tie rod, *a*, fig. 6, Plate XVIII., are secured together by the "gibs," *i i*, *j j*, and cottar, *k k*; an inside edge view of one of the gibs being shown at fig. 7, Plate XVIII. In fig. 2, Plate XIX., we give a side elevation at *a*, fig. 150, showing method of joining the upper end of strut or brace, *c a*, with rafter, *d e*, and queen bolt, *a b*. In fig. 2, Plate XIX., *a a* is rafter; *b*, end of strut, secured to the rafter by plates at each side, one of which is shown at *c c*; the upper end of queen bolt, *d d*, is secured to the plate, *c*, and rafter, *a*,

by a bolt passing through the bolt hole, *e*. Fig. 1 is a side elevation and section of the arrangement taken through the line, *a' b'*, in fig. 2. In fig. 3, side elevation of the arrangement of parts at the point *b*, fig. 150, is shown—*a a*, the lower end of strut or brace, *b*, fig. 150; *b*, the lower end of queen bolt, *d*, in fig. 2, Plate XIX., this passing through the end of flange, *c*, of brace or strut, *a*, and the eye, *d*, of tie bolt, *e e* (corresponding to *c e* in fig. 150), and as shown in plan, fig. 4, Plate XIX. The flange of the strut or brace is shown to be uppermost, as in the arrangement usually adopted, although in some cases the flange is placed on the lowest side, as in

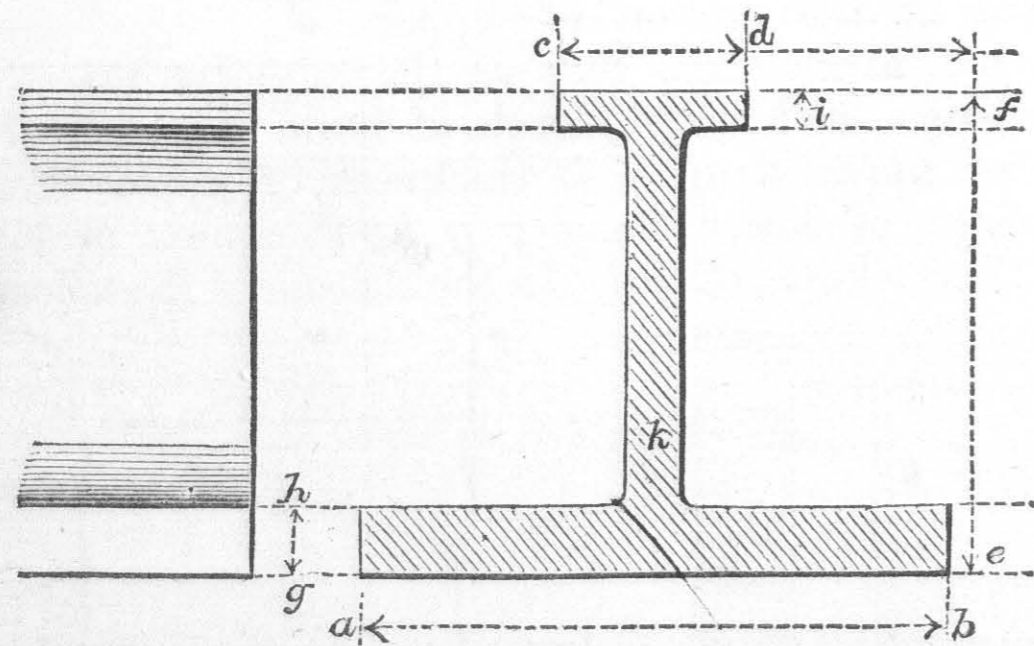

Fig. 153.

fig. 1, Plate XVII., at *g h*. In rafters the flange is always placed uppermost, as shown in fig. 10, Plate XVII., fig. 8, Plate XVIII., and fig. 6, Plate XIX. In fig. 152, we give at A a section, and in B a side elevation, of a wrought-iron rafter of the form used in iron roofs, the drawing showing in full size a section adapted to a roof of 18 to 20 feet span. The arrangement of the parts at *c*, fig. 150 will be very similar to that illustrated in Plate XVII., fig. 1. The arrangement of the parts at *f* and *g*, fig. 150, similar to those illustrated in Plate XIX., figs. 1, 2, 3, and 4. In fig. 5, Plate XVII., a form of

gutter of cast iron adapted to an iron roof is shown; and in fig. 7, same plate, a wrought-iron or zinc one, this being riveted to the end of the flange of the rafter, *a*, prolonged for this purpose beyond the line of rafter box, *b*, and wall, *c*. Other arrangements of roofs and details the reader will find in the *Advanced Course of Building Construction* in this series.

37. Iron Beams.—As substitutes for those of timber, beams are made of cast and wrought iron, and of various forms, the best for cast iron being that illustrated in fig. 153; in this the area of the section of upper flange, *c d*, is one sixth that of the lower flange, *a b*; *e f*, depth of beam over all; *c d*, width of upper flange; *i*, thickness of upper flange; *a b*, width of lower flange; *g h*, thickness of lower flange; *k*, thickness of rib. In the *Advanced Handbook of*

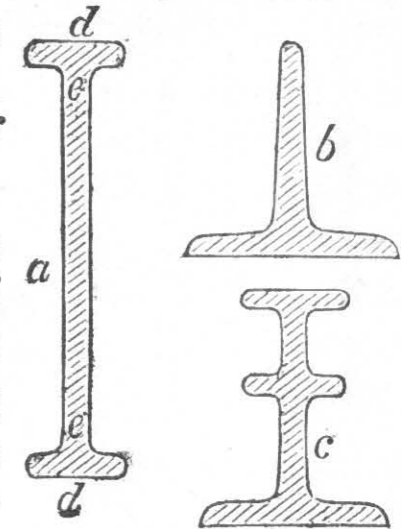

Fig. 154.

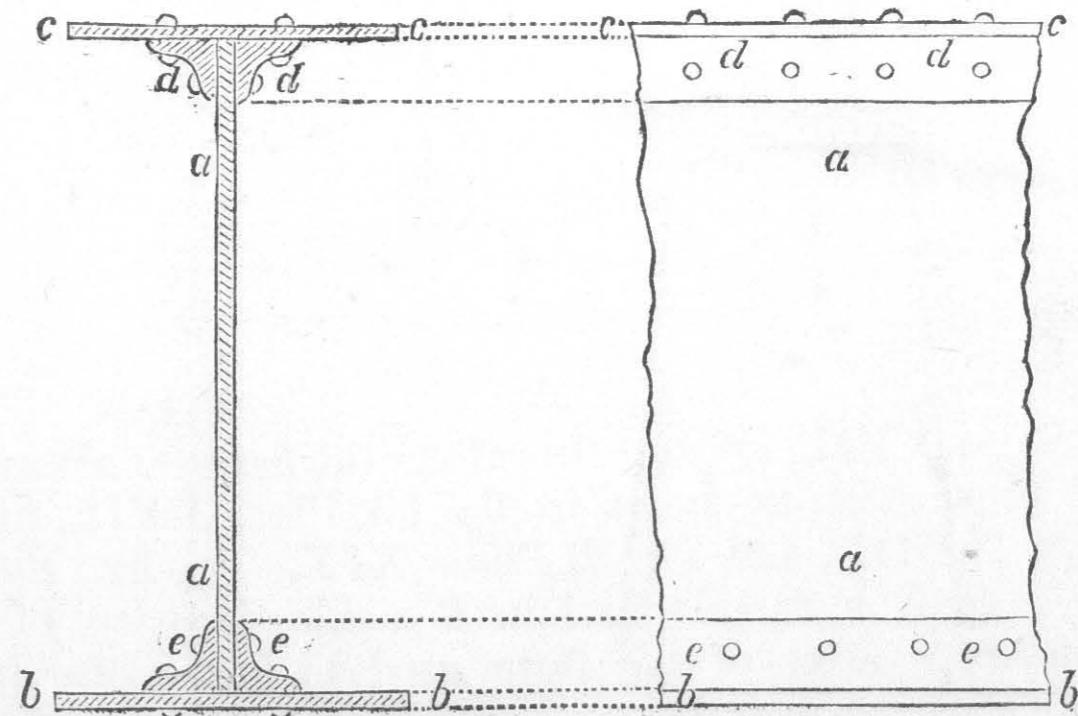

Fig. 155.

Fig. 156.

Building Construction, the reader will find a *resumé* of the peculiarities of cast iron as a building material, and of the reasons why—where the safest and best method of construction is considered—beams of that material should

be discarded in favour of wrought iron, the peculiarities of which will also be described.

The scope of the present work admitting only of general illustrations of form being given, the reader must refer to the same work—above named—for a description of the “strains” to which iron and timber are subjected, and for the principles upon which beams and framework of these materials are designed, to meet the requirements of various positions and localities.

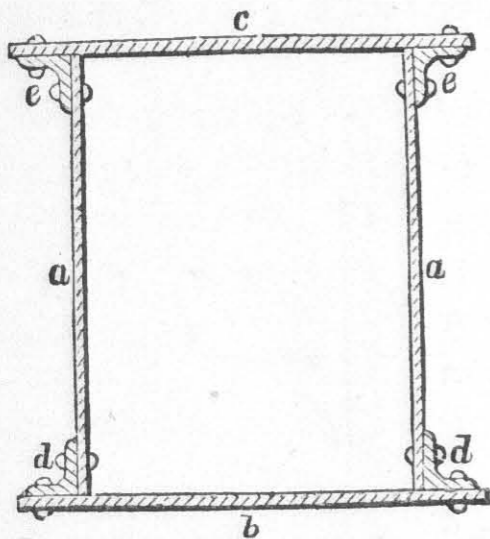

Fig. 157.

Beams of wrought-iron, as now used in practical construction, are of three classes—1st, Solid Rolled, as in fig. 154, *a*, *b*, and *c*, these being used for small spans, and for buildings where comparatively light

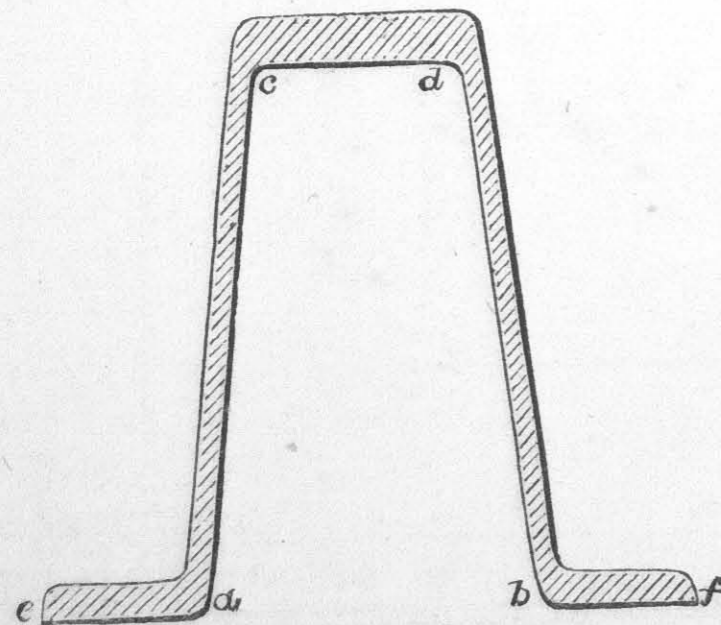

Fig. 158.

weights are to be carried, or small pressure sustained. 2nd, Built Beams (solid), as in figs. 155, 156. 3rd, Built Beams, open or hollow, or, as they are generally

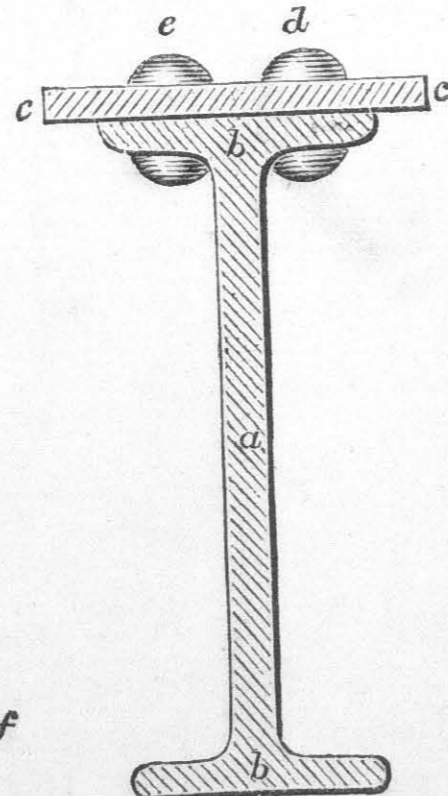

Fig. 159.

termed, “Box Beams,” as in fig. 157. These two latter forms are used when the span is great, and the weights to be supported, or pressure resisted, heavy. 4th, The hollow conical beams, or “Fer Tubulaire,” the invention of M. Zoré, of France. These have for some years been largely used on the Continent, and are now being rapidly introduced into this country into the construction of buildings. This form is illustrated in fig. 158. 5th, Phillips’

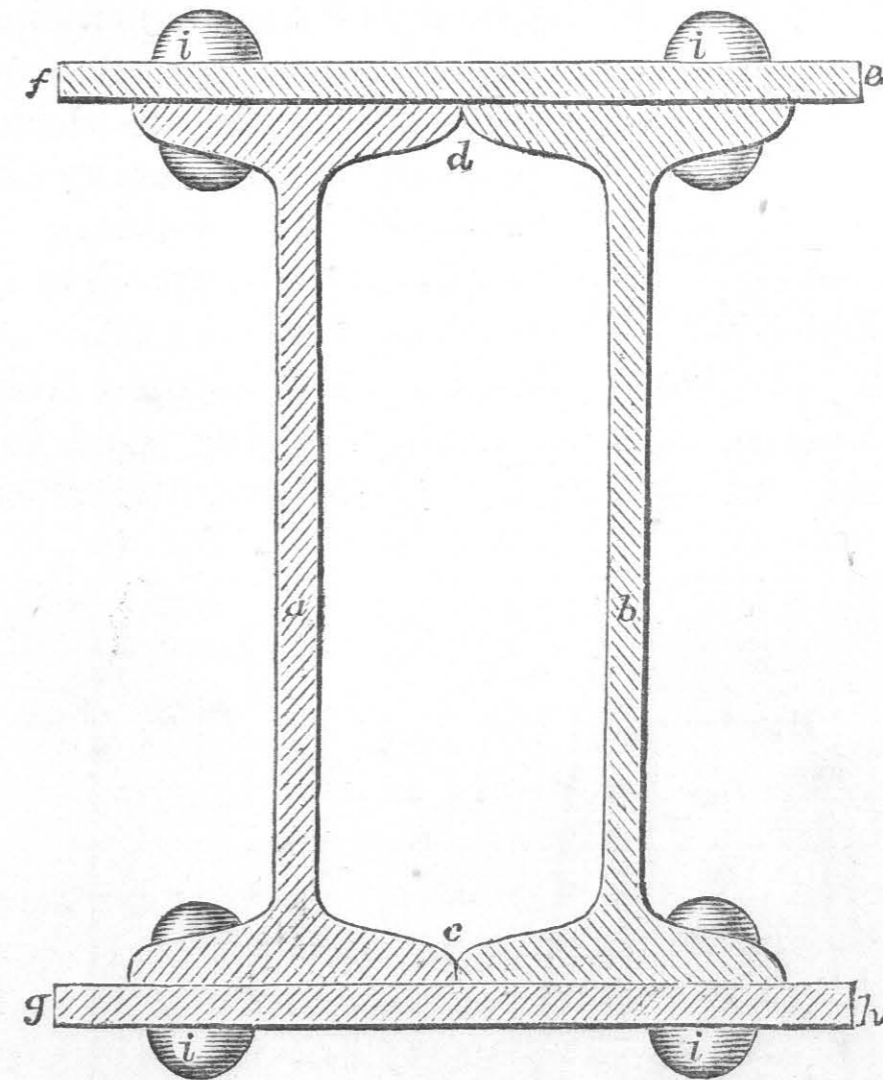

Fig. 160.

Patent Flanged Beams, illustrated in figs. 159 and 160, fig. 159 being a solid, and fig. 160 a box beam on this principle. “Angle irons,” as in fig. 161, and “T-irons,” as in fig. 152, are much used in the construction of built beams, and of wrought-iron roofs, bridges, &c.; “T-irons being used for rafters, and struts or braces; angle irons chiefly for connecting and strengthening various parts. “L-iron,” as in fig. 162, or “channel iron,”

is also used for struts or braces; as also T-iron, placed together as in fig. 163. The following brief notes on the strength of beams, and of the rules for finding their dimensions, will conclude the subject.

In fig. 153, we have given the most approved form of cast-iron beams, in which the sectional area of the bottom flange, $a b$, is six times that of the top flange, $c d$. The best proportion for the depth, $e f$, of a beam is one-twelfth of the span, this being the depth at the centre. But the depth at the bearing ends of the beam may be reduced to two-thirds of the depth at the centre, although in practice it is not usual to make the beam this shape; the top and bottom lines being almost universally made parallel—*i.e.*, the beam of the same depth throughout. The reasons for this will be obvious on considering the case of beams built into brick or stone work, as the upper flange will

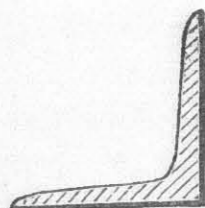

Fig. 161.

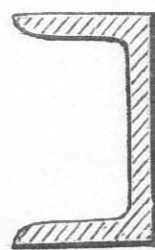

Fig. 162.

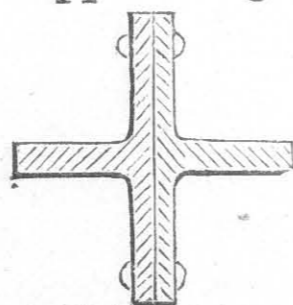

Fig. 163.

be flat throughout its length as required, in which to place the bricks. The bearing of the beams on the wall may be two-thirds of the depth at the centre. The width of the bottom flange at the centre is generally determined by the best proportions in which to distribute the sectional area of the flange; but this width may be reduced at the ends to two-thirds of the width of the centre. This reduction of the breadth of the flange at the ends will give the plan a form, tapering from the centre; the taper or outline is generally made of the parabolic curve. The constant, c , for breaking weight on the centre of cast-iron girders, is 25; or 50 for the weight uniformly distributed over the beam (see *Advanced Course* on strains). The breaking weight of the beam, w , the span, s , and the depth, d , of the beam being known, the

sectional area of the lower flange, $a b$, fig. 153, may be ascertained by multiplying w by s , and dividing the product by d , multiplied by the constant c . The sectional area may be proportioned so as to give a width of bottom flange capable of resisting the strain of pressure to which the beam is to be subjected, the thickness being, say from one-fifth to one-tenth. The thickness of the central web of the beam is generally about the thickness of the bottom flange where it joins the flange, tapering to about the thickness of the top flange, where it joins this. The transverse strength of a cast-iron girder is found by the following formula: where w is the breaking weight, s the span or length of the beam, a the sectional area of the bottom flange in sq. inches, and d the depth of the beam in inches, and c the constant. Then a multiplied by d , multiplied by c , and divided by s . The safe load of a beam is variously estimated as from one-third to one-sixth of the calculated strength. In ascertaining the breaking weight of a beam, it is of course necessary to know the load which it has to carry; this will vary according to circumstances. This, if multiplied by six, assuming the breaking weight to be six times the load, and the quotient multiplied by the span, will give the breaking weight. The constant employed is generally that which will give the breaking weight at the centre; the beam being able to carry double this weight when the load is uniformly distributed over its surface (see strains on materials in the *Advanced Course*). The sectional area of the bottom flange being found by the rule already given; this is to be made up by a flange of a determinate width and thickness; this, if the area is twenty-four square inches, in flange of twelve inches in width by two inches in thickness, will be the dimensions which will absorb, so to say, the sectional area found. Usually the width is determined upon by circumstances, as position and thickness of wall, &c., &c., so that the thickness will be found when the width is determined upon—a good proportion

is for the width of the flange, one half or thereabouts of the depth of the beam; and that, as we have already said, may be taken at one twelfth of the span. The sectional area of the top flange, $c d$, fig. 153, should be one sixth of the area of the bottom flange. As to this proportion, much depends upon the way the beam is loaded; if on the bottom flange, as in the case of bridging joists resting upon it, the proportion of top flange may be one-sixth of the bottom flange; but, if the load is on the top flange, this should bear a greater proportion, say one-third of the bottom flange. The width of the top flange is in practice uniform from end to end.

In beams, the central part, as $e e$ in a , fig. 154, is called the "web"; and $d d$, the top and bottom flanges. In the solid "built" beam, as fig. 155, the "web," $a a$, is a plate of wrought-iron; the "bottom flange," $b b$, being secured by rivets to the "web," a , by the angle "irons," $e e$, the angle irons being of the same length as the "web," $a a$. The "top flange," $c c$, is secured to the upper edge of the "web," $a a$, by the angle irons, $d d$. In fig. 156, we give a side view of fig. 155, this last named figure being a cross vertical section; the corresponding letters show corresponding parts. Fig. 157 is a built beam, but hollow, and is called a "box beam;" in this the sides, $a a$, are made of plates of wrought iron; and these carry a "bottom flange," $b b$, secured to the side plates, $a a$, by the angle irons, $d d$; rivetted by the rivets placed at certain distances from each other, in the manner shown in fig. 156. The "top flange," c , is secured in a similar manner to the upper edges of the side plates, $a a$, by the "angle irons," $e e$. Fig. 158 is a section of the "Zoré," or tubular wrought-iron beam already referred to. This is hollow and conical, or rather, has inclined sides, as $a c, b d$; $e a, b f$ being the flanges in which the beam rests; the load being carried on the upper flange, or the top plate, $c d$. In fig. 159, a section of Phillips' patent wrought-iron beam is given; it is simply a beam, a , with top and bottom flanges, $b b$,

of the ordinary form, but with an additional plate or flange, $c c$, secured to the upper flange, b , of the beam, a , by rivets, as $d e$. This addition, simple as it is, gives great additional strength to the beam, $a b b$. Fig. 160 shows a box beam on this principle, which is made up of two beams, $a b$, of the ordinary form, with the ends of their upper and lower flanges coming in contact at the points, $c d$; the upper plate, $f e$, and the lower, $g h$, are secured by the rivets, $i i$.

In Plate XX. we give one-half of a transverse vertical section of a warehouse or factory, taken on a line across its breadth; $a a$, the walls, the footings of which rest upon concrete, $d d$; as also the stone bases, $e e$, of the cast-iron pillars supporting the wrought-iron beam flooring, $g g g-h h h$, mark the portion of the cross or longitudinal beams for supporting flooring timbers. The iron roof is shown at $i i$; j , the rafter box; $k k$, the rafter; $l l$, the tie-rod; m , the king bolt; n, o , the queen bolts; p , the struts or braces; r , the gutter.



INDEX.

APPLIANCES for Drawing, 9-16.

BARS, Sash, for Windows, 91.
 Beam, Trellis or Open, 45.
 Beams, Cast Iron, 126.
 Fishing of, 40.
 Flitches in, 43.
 Increasing the Depth of, 42.
 Increasing the Thickness of, 43.
 Iron, Proportions of, 130.
 in Iron, Wrought and Cast, 126.
 Lengthening of, 40.
 Scarfig of, 41.
 Trimming, 44.
 Wrought Iron, 127.
 Binding Joists, 29.
 Boarding, Weather, 55.
 Boards, Flooring, 32.
 Boards, Skirting, 36.
 Bolts and Straps, Iron, 116.
 Braced, Framed, and Trussed Partition, 46.
 Brestsummers, or Bressumers, 45.
 Bricknogging in Partitions, 46.
 Bridging Gutter, 58.
 Bridging Joists, 29.
 CANTALEVER, 56.
 Casings of Doors, 81.
 Cast-iron Beams, 126.
 Ceiling Joists, 28.
 Centres, 70.
 Cogging, Caulking, or Keying of beams, 42.
 Collar Beam Roof, 50.
 Columns, Iron, 118.
 Couple or Span Roof, 50.
 Covering for Roof, 52.
 "Curves" for Drawing, 12.
 DEPTH, Increasing the, of Beams, 41.
 Detail Drawings, Scales for, 22.
 Doors and Windows, Furniture of, *i.e.*, Locks, Hinges, &c., &c., 93-98.
 Doors—
 Architrave, 82.
 Casings of, 81.
 Framed and Ledged, 79.

Doors—

Framed and Panelled Door, 80.
 Hanging of, and Windows, 93.
 Interior or Dining Room, 80.
 Ledged, 79.
 Ledged and Braced, 79.
 Ledged, Framed, and Braced, 80.
 Panels, 83.
 Jambs of, 81.
 Various Forms of, 78.
 Double and Framed Floors, 29.
 Dowelled Floors, 33.
 Drawing Appliances, 9-16.
 Board, 9.
 Instruments, 13.
 Paper and Pencils, 1-11.
 Scales used in, 1-11.
 Drawings, Scales for Detail, 22.
 ELEVATIONS, Plans, and Sections, 23.
 FISHING of Beams, 40.
 Flashings, Lead.
 Flitching of Beams, 43.
 Flooring Boards, 32.
 Joints in, 35.
 Flooring Joists, 27.
 Floors, Double Framed, 30.
 Dowelled, 33.
 Framed and Double, 29.
 Joining of Timber in, 37.
 Single, 28.
 Straight Joint, 33.
 Framed and Double Floors, 29.
 Framed, Braced, and Trussed Partition, 46.
 Framed Partition, 46.
 Furniture, Locks, &c., of Doors and Windows, 93-98.
 GIRDER, 31.
 Gutter, Valley, 57.
 Gutters, Bead Lining of, 114.
 Gutters of Roofs, 56.
 HANGING of Shutters, 95.
 Hingeing of Doors and Windows, 93.
 Hip or Hipped Roof, 51.

INSTRUMENTS for Drawing, 13.
 Iron and Timber Roofs, 119.
 Iron Beams, Proportions of, 130.
 Columns, 118.
 Roofs, 121.
 Straps and Bolts, 116.
 Wrought, Beams, 127.

JOINERY, Joints in, 99-110.
 Joining of Timbers in Floors, 37.
 Joining of Timbers in Roofs, 59, 60.
 Joinings of Timbers in Partitions, 47.
 Joints in Flooring Boards, 35.
 Joints in Joinery, Various Kinds and Names of—
 Architraves, 110.
 Blockings, 107.
 Brackets, 109.
 Chamfering, 102.
 Clamping, 103.
 Cross Grooving, 103.
 Dovetail Joints, 108.
 Joints at Obtuse Angles, 107.
 Joints at Right Angles, 106.
 Ledging, 103.
 Mitre Clamped, 104.
 Mortise and Tenon, 105.
 Ploughed, 101.
 Ploughed and Tongued, 101.
 "Rebate," 101.
 Slip Feather, 101.
 Stop Chamfer, 102.
 Tongue or Feather, 101.
 Joints, Miscellaneous, in Timber, 73-76.

KING-POST Roof, 50.

LEAD Coverings for Parapets, 115.
 Lead Flashings, 111.
 Lead Linings for Gutters, 114.
 Lean-to or Shed Roof, 49.
 Lengthening of Beams, 40.

MISCELLANEOUS Joints in Timber, 73-76.
 Mouldings, 99.

PANELS of Doors, Kinds and Parts of—
 Bead and Butt, 84.
 Bead and Flush, 84.
 Flush, 83.
 Laid on, 85.
 Lying, 82.
 Margin of a Panel, 83.
 Mitre, 85.
 Moulded Raised Panel, 84.
 Raised, 83.
 Square, 82.
 Stuck on, 85.
 Partitions, 46-48.

Partitions, Joints of Timbers in, 47.
 Plans, Elevations, and Sections, 23.
 Proportions of Iron Beams, 130.

QUARTERING Partition, 46.
 Queen-post Roof, 51.

ROOFS, 49-51.

Covering for, 52.
 Gutters of, 56.
 in Iron and Timber, 119.
 Joining of Timbers in, 59.
 of Iron, 121.
 Collar Beam, 67.
 Dragon Beam, 69.
 Hip Rafter, 69.
 King-post, 62.
 Parts of tie Beams, Wall Plates, 60.
 Purlin, 65.
 Queen-posts, 64.
 Rafter, 61.
 Ridge Pole, 64.
 Struts or Braces, 63.
 Rulers for Drawing, 12.

SASH Bars for Windows, 91.
 Scales for Detail Drawings, 22.
 Scales, Practical use of, 16-19.
 Scales used in Drawing, 1-11.
 Scarfig of Beams, 41.
 Sections, Plans, and Elevations, 23.
 Shutters, Hanging of, 95.
 Shutters, Window, 91.
 Single Floors, 28.
 Skirting Boards, 36.
 Slates, Fixing of, on Roof, 53.
 Span or Bearing of a Floor, 28.
 Span or Couple Roof, 50.
 Straight Joint Floors, 33.
 Straps and Bolts, Iron, 116.
 Strutting of a Floor, 29.

THICKENING of Beams, 43.
 Thickness, Increasing the, of Beams, 43.
 Timber and Iron Roofs, 119.
 Timber Joints, Miscellaneous, 73-76.
 Timbers, Joining of, in Roofs, 59.
 Timbers, Joints of, in Partitions, 47.
 Trellis, or Open Beam, 45.
 Trimmer, Trimming Joists, 30.
 Trimming of Beams, 44.
 Trussed, Framed, and Braced Partition, 46.
 "T" Square, 9.

VALLEY Gutter, 57.

WALL Plates, 27, 39.
 Weather Boarding, 55.
 Window Shutters, 91.

- Window Shutter Flaps, 92.
Kinds and Parts of Folding, 92.
Lifting, Rolling, 92.
Shutter Boxings, 92.
Windows and Doors, Furniture of, *i. e.*,
Locks, Hinges, &c., &c., 93-98.
Windows and Doors, Hinging of, 93.
Windows, Sash Bars for, 91.
Windows, Various Forms of—
Beads, 89.
Cased Framing, 87.
Casement, French Casement, 87.
Casing Pieces, 88.
- Windows—
Cill or Sill, 87.
Fixed, 86.
Hung, Double Hung, Single Hung,
86.
Lining, 88, 89.
Panes of Glass, 90.
Parting Slip, 88.
Pulley Pieces and Styles, 89.
Sash, 86.
Sash Bars, 91.
Sash Weight, 88.
Solid Sash Frame, 87.

COLLINS' SERIES OF FIRST-CLASS SCHOOL ATLASES,

Carefully Constructed and Engraved from the best and latest Authorities, and Beautifully Printed in Colours, on Superfine Cream Wove Paper.

MODERN GEOGRAPHY—Crown Series. s. d.

MY FIRST ATLAS, consisting of 12 Maps, 9 inches by 7½ inches, folded 8vo, in Neat Wrapper,	0	6
THE PRIMARY ATLAS, consisting of 16 Maps, 9 inches by 7½ inches, 4to, Stiff Wrapper,	0	6
THE POCKET ATLAS, consisting of 16 Maps, folded in 8vo, and mounted on Guards, cloth lettered,	1	0
THE JUNIOR, OR YOUNG CHILD'S ATLAS, consisting of 16 Maps, 4to, with 16 pp. of Questions on the Maps, in Neat Wrapper,	1	0
THE STANDARD SCHOOL ATLAS, consisting of 24 Maps, Crown 4to, in Neat Wrapper,	1	0
THE PROGRESSIVE ATLAS, consisting of 32 Maps, 9 inches by 7½ inches, 4to, cloth lettered,	2	0
THE CROWN ATLAS, consisting of 32 Maps, on Guards, with Index, 8vo, cloth lettered,	2	6
THE NATIONAL ATLAS, consisting of 32 Maps, 4to, with a Copious Index, cloth lettered,	2	6

MODERN GEOGRAPHY—Imperial Series.

THE SELECTED ATLAS, consisting of 15 Maps, Imperial 4to, 11 by 13 inches, Stiff Cover,	1	6
THE PORTABLE ATLAS, consisting of 16 Maps, folded Imperial 8vo, cloth lettered,	2	0
THE ADVANCED ATLAS, consisting of 32 Maps, Imperial 4to, cloth lettered,	3	6
THE ACADEMIC ATLAS, consisting of 32 Maps, Imperial 4to, with a Copious Index, cloth lettered,	5	0
THE STUDENT'S ATLAS, consisting of 32 Maps, and 6 Ancient Maps, with a Copious Index, Imperial 8vo, cloth lettered,	6	0
THE COLLEGIATE ATLAS, consisting of 32 Modern, 16 Historical, and 2 Ancient Maps, mounted on Guards, with a Copious Index, Imperial 8vo, cloth lettered,	7	6
THE INTERNATIONAL ATLAS, consisting of 32 Modern, 16 Historical, and 14 Maps of Classical Geography, with Descriptive Letterpress on Historical Geography, by W. F. Collier, LL.D.; and on Classical Geography, by L. Schmitz, LL.D., with Copious Indices, Imperial 8vo, Cloth mounted on Guards,	10	6

PHYSICAL GEOGRAPHY—Demy Series.

THE PRIMARY ATLAS OF PHYSICAL GEOGRAPHY, 16 Maps, Demy 4to, 9 by 11 inches, Stiff Cover,	1	0
THE POCKET ATLAS OF PHYSICAL GEOGRAPHY, 16 Maps, on Guards, Demy 8vo, cloth,	2	0

London, Edinburgh, and Herriot Hill Works, Glasgow.

COLLINS' SERIES OF SCHOOL ATLASES—CONTINUED.

PHYSICAL GEOGRAPHY—Imperial Series. s. d.

THE PORTABLE ATLAS OF PHYSICAL GEOGRAPHY, 20 Maps, 11 by 13 inches, mounted on Guards, Imp. 8vo, cloth, ...	3	6
THE STUDENT'S ATLAS OF PHYSICAL GEOGRAPHY, 20 Maps, mounted on Guards. With Letterpress Description and Wood Engravings. By James Bryce, LL.D., F.R.G.S. Imp. 8vo, cl.,	5	0

HISTORICAL GEOGRAPHY.

THE POCKET ATLAS OF HISTORICAL GEOGRAPHY, 16 Maps, 6½ by 11 inches, mounted on Guards, Imperial 16mo, cloth,	1	6
THE CROWN ATLAS OF HISTORICAL GEOGRAPHY, 16 Maps, with Letterpress Description by Wm. F. Collier, LL.D., Imperial 16mo, cloth,	2	6
THE STUDENT'S ATLAS OF HISTORICAL GEOGRAPHY, 16 Maps, Letterpress Description by Wm. F. Collier, LL.D., 8vo, cloth,	3	0

CLASSICAL GEOGRAPHY.

THE POCKET ATLAS OF CLASSICAL GEOGRAPHY, 15 Maps, Imperial 16mo, 6½ by 11 inches, cloth lettered,	1	6
THE CROWN ATLAS OF CLASSICAL GEOGRAPHY, 15 Maps, with Descriptive Letterpress, by Leonhard Schmitz, LL.D., Imperial 16mo, cloth lettered,	2	6
THE STUDENT'S ATLAS OF CLASSICAL GEOGRAPHY, 15 Maps, Imperial 8vo, with Descriptive Letterpress, by Leonhard Schmitz, LL.D., cloth lettered,	3	0

SCRIPTURE GEOGRAPHY.

THE ATLAS OF SCRIPTURE GEOGRAPHY, 16 Maps, with Questions on each Map, Stiff Cover,	1	0
THE POCKET ATLAS OF SCRIPTURE GEOGRAPHY, 16 Maps, 7½ by 9 inches, mounted on Guards, Imp. 16mo, cloth, ...	1	0

BLANK PROJECTIONS AND OUTLINES.

THE CROWN ATLAS OF BLANK PROJECTIONS, consisting of 16 Maps, Demy 4to, on Stout Drawing Paper, Stiff Wrapper, ...	0	6
THE CROWN OUTLINE ATLAS, 16 Maps, Demy 4to, Stout Drawing Paper, Stiff Wrapper,	0	6
THE IMPERIAL ATLAS OF BLANK PROJECTIONS, consisting of 16 Maps, Imperial 4to, on Stout Drawing Paper, Stiff Wrapper,	1	6
THE IMPERIAL OUTLINE ATLAS, 16 Maps, Imperial 4to, Stout Drawing Paper, Stiff Cover,	1	6

London, Edinburgh, and Herriot Hill Works, Glasgow.