

SUNNYBRAE
COTTAGE,
PITLOCHRY

R | Research
Report

R | Research Report

Sunnybrae Cottage, Pitlochry

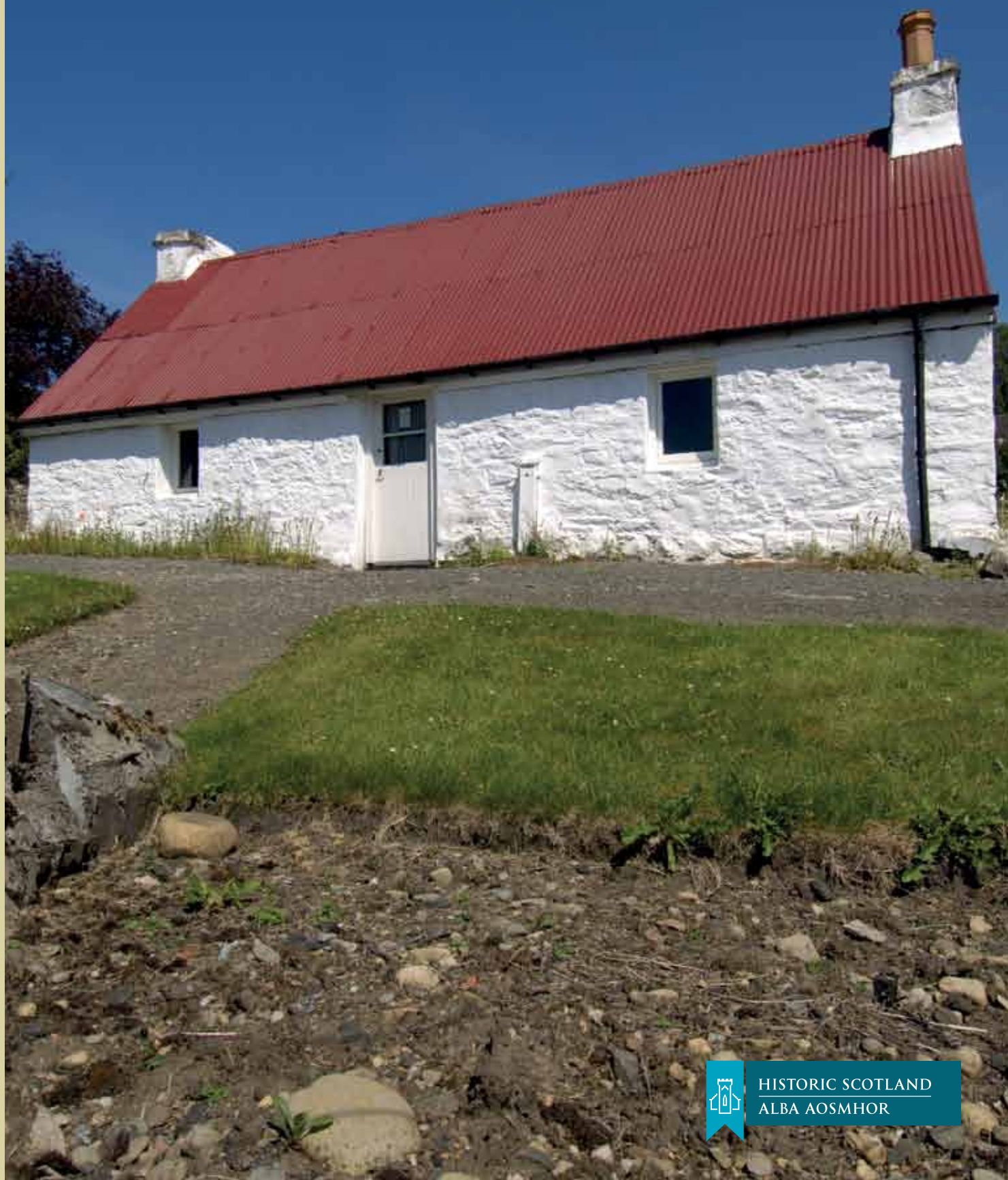

HISTORIC SCOTLAND
ALBA AOSMHOR

R | Research Report

SUNNYBRAE COTTAGE, PITLOCHRY

by

Timothy G Holden* and
Bruce Walker**

*Headland Archaeology Ltd,
13 Jane Street, Edinburgh EH6 5HE

**149 Strathern Road, West Ferry,
Dundee DD5 1BR

ISBN: 978-1-84917-088-8

Historic Scotland
© Crown copyright
Edinburgh, 2012



HISTORIC SCOTLAND
ALBA AOSMHOR

Available from:
Historic Scotland
Longmore House
Salisbury Place
Edinburgh
EH9 1SH
Tel 0131 668 8638
Fax 0131 668 8669
email hs.cpublications@scotland.gsi.gov.uk

While every care has been taken in the preparation of this book. Historic Scotland specifically exclude any liability for errors, omissions or otherwise arising from its contents.

CONTENTS

	<i>Page</i>		<i>Page</i>
LIST OF ILLUSTRATIONS	iv	4 LATER ‘IMPROVED’ HOUSE –	41
TABLES	viii	PHASE 3	
FOREWORD	ix	4.0 Introduction	41
ACKNOWLEDGEMENTS	x	4.1 The floors and walls	43
1 INTRODUCTION	1	4.2 The roof	44
1.0 The present project	1	4.3 Internal refurbishment and layout	45
1.1 Description of the building	3	4.4 Furnishings	48
1.2 Strategy for the investigation	5	4.5 Discussion of Phase 3	48
1.3 Archaeological fieldwork and analysis	6	5 20th-CENTURY HOUSE – PHASE 4	50
1.4 Interpretation and presentation	7	5.0 Introduction	50
2 HIGHLAND HOUSE – PHASE 1	8	5.1 The brick extension and other structural works	51
2.0 Introduction	8	5.2 Internal layout	54
2.1 Solum, foundation course and floors	8	5.3 Furnishings	54
2.2 Timber structure	10	5.4 Floorcovering and wallpapers	55
2.3 Turf walls	19	5.5 Discussion of Phase 4	57
2.4 Thatched roof	22	6 1998 TO THE PRESENT	58
2.5 Internal layout	24	7 LESSONS LEARNED	60
2.6 Hearth	27	REFERENCES	62
2.7 Furnishings	27	ARCHIVE SOURCES	63
2.8 Discussion of Phase 1	28	GLOSSARY	64
3 THE EARLY ‘IMPROVED’ HOUSE –	29	APPENDICES	66
PHASE 2			
3.0 Introduction	29		
3.1 Timber floors	29		
3.2 Masonry walls	31		
3.3 Thatched roof	34		
3.4 The extension against the W wall	35		
3.5 Internal layout	36		
3.6 Canopy chimney	37		
3.7 Furnishings	39		
3.8 Discussion of Phase 2	39		

LIST OF ILLUSTRATIONS

		<i>Page</i>			<i>Page</i>
1	INTRODUCTION		Illus. 13	Details of the W cuppill (HS)	12
Illus. 1	Location plan (CW)	1	Illus. 14	Details of the E cuppill (HS)	13
Illus. 2	Site plan 1998 (LP)	1	Illus. 15	Exposed cuppill post and joint in N wall of E room (Historic Scotland)	14
Illus. 3	Pitlochry shown on the 1846 Faskally Estate Plan (Mclagan)	2	Illus. 16	The apex of the W face of the W cuppill showing the pegging (Historic Scotland)	14
Illus. 4	The cottage lies at the junction of Atholl Road and Larchwood Road 1998 (Historic Scotland)	3	Illus. 17	Selecting the timber (BW)	14
Illus. 5	The roof space 1998 (Historic Scotland)	3	Illus. 18	Lapped joint with face-to-face pegging forming a clasped joint due to the pegs being angled (BW)	15
Illus. 6	Photo of exposed cuppill in W room (Historic Scotland)	4	Illus. 19	Details of pegging on the E face of the E cuppill (Historic Scotland)	15
Illus. 7	Building recording in progress (Historic Scotland)	4	Illus. 20	Inferred mid-collar form (BW)	15
Illus. 8	The scaffolding shell	5	Illus. 21	Timber marks (LP)	16
Illus. 9	Children from the local primary school offer some alternative interpretations 2000 (Historic Scotland)	6	Illus. 22	Detail of timber marks – W cuppill, N sile (Historic Scotland)	16
2	HIGHLAND HOUSE – PHASE 1		Illus. 23	An unframed pit-saw (BW)	18
Illus. 10	a) Phase 1-2 Longitudinal section showing N internal wall (Historic Scotland)	9	Illus. 24	A framed pit-saw (BW)	18
	b) Phase 1-2 Longitudinal section showing S internal wall (Historic Scotland)	9	Illus. 25	Sawing on a saw horse (BW)	18
	c) Phase 1-2 Cross section and elevation. – W wall (Historic Scotland)	9	Illus. 26	Pit-sawing on a trestle or in a pit (BW)	18
	d) Phase 1-2 Cross section and elevation. – E wall (Historic Scotland)	9	Illus. 27	How timber was sawn a) a log, b) with sides axed away, c) two rip saw cuts producing two sile blades and a central section that could be used elsewhere (BW).	18
Illus. 11	The W gable wall showing an area of exposed wall core is formed of orange subsoil and has been raked out and replaced with brickwork wherever it remained exposed (Historic Scotland)	10	Illus. 28	Suggested construction sequence for Phase 1 a) The site is cleared and levelled (BW) b) The footings are formed of boulders with a subsoil core (BW) c) The cuppills are guyed temporarily while the purlins and other timberwork are fixed (BW) d) The roof tree is added and the lining for the turfwalls erected (BW) e) Purlins are added and the lining erected throughout with either cabers or wattle (BW) f) The turf walls are constructed and cabers of roof added (BW)	19
Illus. 12	A sample section through the N wall showing the wall core of the original footings (MM). The lack of structural bonding in the wall indicates that this is what was known in Scotland as ‘clay wall’ which is gradually introduced in the last years of the 18th century (Walker 1992)	10			

	<i>Page</i>		<i>Page</i>
	19	g) The gable walls are constructed and the canopy chimney erected (BW)	19
	19	h) The thatch is put on with a ridge of turf (BW)	19
	19	i) The skewers are build up with turf to complete the roof (BW)	19
Illus. 29	20/21	Different styles of turf bonding	20/21
		a) fale – wide shallow cut	
		b) fale – narrow deep cut	
		c) fale – wide shallow cut and divot	
		d) fale – narrow deep cut and divot	
		e) Alternating stone and turf. Flattish stones were preferred but any type of stone was used, usually field clearance boulders	
Illus. 30	22	Straw and turf exposed at the surface after cleaning (Historic Scotland)	22
Illus. 31	22	An excavated section through the thatch (Historic Scotland)	22
Illus. 32	22	The thatch of the S pitch in section (MM)	22
Illus. 33	23	Tippets or grips from the body of the roof (Historic Scotland)	23
Illus. 34	23	The excavation of the turf at the ridge – note the rodent hole in the section (Historic Scotland)	23
Illus. 35	23	Turf layers overlying the ridge: N facing section (MM)	23
Illus. 36	24	Reconstruction showing how the building may have looked in Phase 1 – a turf building with thatched roof, turf ridge and central smoke hole –	24
		a) S elevation	
		b) E elevation (BW)	
Illus. 37	24	Reconstruction – interior plan (BW)	24
Illus. 38	24	Reconstruction – long and short sections showing the interior (BW)	24
Illus. 39	25	Reconstruction – perspective	25
		a) facing W	
		b) facing E (BW)	
Illus. 40	26	Byre loft – house cleared for a party or wedding (BW after David Allen 1744-96)	26
Illus. 41	26	Approach of the Enemy – Painting with young woman sitting beside the hearth and old woman coming in the door and past a screen or hallan – Erskine-Nicol (26/53) 1865 © (Dundee Museum & Art Gallery)	26
Illus. 42	27	A Cottars Saturday Night – David Allan 1789 © (National Galleries D/NG562)	27
Illus. 43	28	Two men drinking at a table in an inn – Walter Geikie © (National Galleries D4553)	28
		3 THE EARLY ‘IMPROVED’ HOUSE – PHASE 2	
Illus. 44	29	Faskally Estate Map of 1846 P Mclagan	29
Illus. 45	30	a) Longitudinal section of N internal wall (HS)	30
	30	b) Longitudinal section of S internal wall (HS)	30
	30	c) Cross sections and elevation – W wall (HS)	30
	30	d) Cross sections and elevation – E wall (HS)	30
Illus. 46	30	The Ordnance Survey maps for 1862 and 1900	30
Illus. 47	31	Ground plan of the Early ‘Improved’ House (HS)	31
Illus. 48	31	A section of the battered N wall (Historic Scotland)	31
Illus. 49	32	Suggested construction sequence for Phase 1	32
	32	a) The turf walls are removed in sections with roof supported on the cuppills (BW)	32
	32	b) Sections of turf are replaced by stone masonry (BW)	32
	32	c) Gable walls are of stone, canopy chimney installed and the gable walls made to full height with layers of turf (BW)	32
	32	d) Central smoke hole blocked, gables and ridge finished with turf (BW)	32
	32	e) The thatch may have been carried over an outhouse against the W wall	32
	32	f) The completed building and outhouse from the rear showing the possible use of ‘backs’ (BW)	32
Illus. 50	33	Turf is commonly used at the gable head where it provides a good seal between wall and thatch. It is applied in horizontal courses of divot and pegged through the courses below (BW)	33
Illus. 51	34	A fragment of the <i>The Scotsman</i> newspaper from 1861	34
Illus. 52	34	Close up of the false chimney on the W gable (Historic Scotland)	34
Illus. 53	35	Log squared to produce a balk and backs (BW)	35
Illus. 54	35	Timber extension (Atholl estate archives)	35
Illus. 55	35	Timber extensions using ‘backs’ in Pitlochry (GWW 1101)	35

	<i>Page</i>		<i>Page</i>
Illus. 56	35	Illus. 67	43
Illus. 57	36	Illus. 68	43
Illus. 58	36	Illus. 69	43
Illus. 59	36	Illus. 70	44
Illus. 60	37	Illus. 71	45
Illus. 61	37	Illus. 72	45
Illus. 62	37	Illus. 73	46
Illus. 63	38	Illus. 74	47
Illus. 64	38	Illus. 75	47
Illus. 65	39	Illus. 76	47
4		Illus. 77	47
		Illus. 78	47
		Illus. 79	48
		Illus. 80	48
		Illus. 81	48
		Illus. 82	48
Illus. 66	42		

**LATER 'IMPROVED' HOUSE –
PHASE 3**

Illus. 66	42		

5 20th-CENTURY HOUSE – PHASE 4

Illus. 83	View from the N 1998 (Historic Scotland)	50
Illus. 84	View from the S 1998 (Historic Scotland)	50
Illus. 85	The hearth in the W room 1998 (Historic Scotland)	50
Illus. 86	The E room looking towards the front door 1998 (Historic Scotland)	50
Illus. 87	Phase 4 Survey drawings a) N wall (HS), b) S wall (HS), c) W gable (Historic Scotland) d) E gable (Historic Scotland)	51
Illus. 88	Plan of the cottage (LP)	52
Illus. 89	A brick extension is built against the N wall (BW)	52
Illus. 90	Costed proposal for work 1945	53
Illus. 91	A typical post-war scullery – No 32 Maidencraig Crescent, Edinburgh (SCRAN)	54
Illus. 92	Floorcoverings	55
Illus. 93	Wallpaper samples	56
Illus. 94	Cuppill base and steel shoe (Historic Scotland)	59

Illustrations were by Bruce Walker (BW), Craig Williams (CW), Laura Speed (LS), Lyal Purves (LP) and Mike Middleton (MM).

TABLES

	<i>Page</i>
Tables:	
Table 1 – Plant materials used on the roof	22
Table 2 – The owners and occupants between 1814 and 1857	29
Table 3 – The owners and occupants of Sunnybrae Cottage 1871-1934	41
Table 4 – The owners and occupants of Sunnybrae Cottage 1934-1998	50
Table 5 – Floorcoverings	55
Table 6 – Wallpaper samples	56

FOREWORD

When viewed from the street, Sunnybrae Cottage, sitting on the western edge of Pitlochry in Perthshire, has the unimposing presence of many typical Highland cottages and but for the intervention of the local history group in bringing the property to the attention of Historic Scotland (HS) in 1997 a unique opportunity to study this form of vernacular dwelling may have been lost. At the first glance nothing seems extraordinary about the building and a visit to the cottage by Chris McGregor and Bruce Walker seemed to endorse that impression. The interior was a simple three-roomed plaster-boarded arrangement with a later extension to the rear. Not until Chris and Bruce peered up through a ceiling hatch into a gloomy roof space was the first impression dramatically reversed. For through the darkness, illuminated by torch light, the hidden gem of a rare survival of a Celtic cuppill roof was unveiled. The soot-blackened roof timbers and thatch triggered the need for further investigation and based on its cultural merit the property came into the care of Historic Scotland.

What followed was a painstaking archaeological recording and study of the cottage. Like peeling an onion, the interior layers were carefully stripped back to afford fuller investigation and understanding of the building. Sunnybrae Cottage is unique amongst the many and varied properties that Historic Scotland holds in care for the nation. This small building has given us the opportunity to study the life and times of vernacular domestic architecture in a dwelling that was inhabited up until 1997. We can see how the building was constructed, used and adapted, within a documented occupation of over 150 years starting from the 1841 census, and yet has seen little change in material, form and appearance.

This report brings together the findings from several years of building investigation and background research by Historic Scotland working alongside Headland Archaeology, Timothy Holden and Bruce Walker. The building has revealed its past to the experts in this field and we can now share our findings as we consider the next stage in the future presentation of Sunnybrae Cottage.

Chris McGregor
Head of Major Projects
Historic Scotland
March 2011

ACKNOWLEDGEMENTS

The authors would like to thank the people of Pitlochry, particularly Pat David and Colin Liddell who provided additional documentary and map evidence, Nancy McEwan, Hugh Campbell and William Higgins and the members of the Moulin and Pitlochry History Circle for passing on their local knowledge. William Higgins also donated a clock and the family photo from the house to the project. We would also like to thank Chris McGregor,

Graeme Bell, Doreen Grove, Kirsty Owen and Sabina Strachan who managed the project for Historic Scotland and also Lyal Purves, Neil Macfarlane and Bernard McCallum who undertook much of the site survey work. Thanks also to the survey and excavation teams Margaret Engl, Jonathan Millar, Mhairi Hastie, Louise Baker, Laura Speed and also Chris Lowe and Sabina Strachan for comments on the final text.

1 INTRODUCTION

1.0 The present project

Sunnybrae Cottage is situated near the western extremity of the settlement of Pitlochry and is part of an Historic Scotland property-in-care that includes the cottage, the plot in which the cottage sits and its boundary walls (Illus. 1 & 2). It is cared for by Historic Scotland on behalf of Scottish Ministers who acquired the property in June 1998 as a well-preserved and rare example of a Highland cottage. Its location, on the main street of a popular tourist town, provides an important educational resource from which to promote an interest in Scottish building traditions. Since its purchase the cottage has been the focus of an in-depth research project specifically designed to:

- enhance its presentation to the public
- inform proposals for its long-term conservation
- advance the study of vernacular buildings

The cottage lies on an E/W axis, roughly parallel to the contours of a S-facing bank on the N side of Atholl Road

at its junction with Larchwood Road. Atholl Road is the original 18th-century military road that formed the principal route from Perth to various forts and smaller barracks in the Central Highlands. This military road also became the principal tourist route into the Central Highlands and in both its civil and military use would form a source of influence for Lowland culture. Sunnybrae Cottage may have been in existence before the road was constructed or it may have been built to take advantage of the potential generated by the road. Certainly, the immediate environment of the cottage has changed considerably since the construction of the military road. In the late 1790s, Pitlochry was a small settlement of 30 families (Stewart 1791) and the cottage must have been a part of a diffuse rural settlement at that time. But in 1844 it was visited by Queen Victoria and soon after this date became a major centre for tourism (Illus. 3). By the end of the 19th century, Pitlochry had seven hotels, three banks, four churches and various other new buildings and was reckoned to be a favourite summer resort (Keat and Keat 1994). The cottage was then, as it is now, on the outskirts of a busy tourist town.

Illus. 1 Location plan (CW)



The possibility that Sunnybrae Cottage was about to come onto the market was brought to the attention of Historic Scotland by the Moulin and Pitlochry History Circle in 1997. As a relatively humble vernacular building, this presented an unusual and exciting opportunity for Historic

Illus. 2 Site plan 1998 (LP)

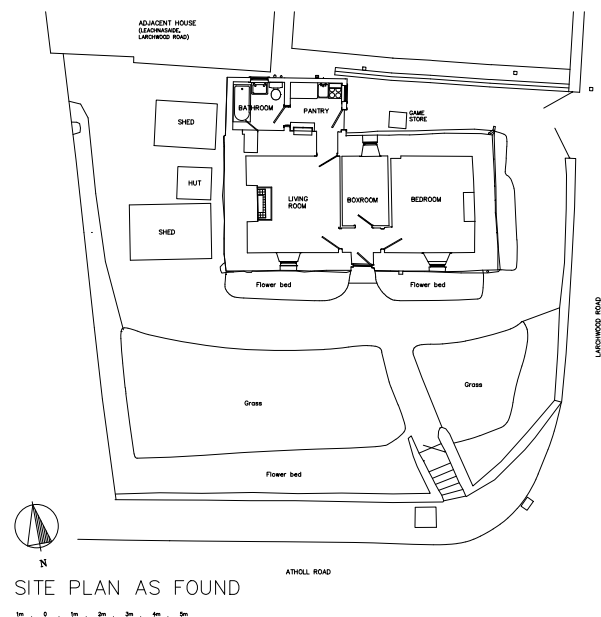

Scotland to acquire a form of building that although once very common, is now rare. Historic Scotland considered the significance of the cottage by their normal criteria, in particular, looking at its constructional and social importance as a representative sample of this form of dwelling in Scotland. The survival of what appeared to be several periods of repair and alteration to the cottage walls and a thatched roof beneath a later corrugated iron covering, offered the opportunity to investigate and study the development of the cottage.

Historic Scotland then decided it would approach the then owners to discuss acquisition. This process was concluded the following spring when Sunnybrae Cottage came into care to be safeguarded by the Secretary of State (now Scottish Ministers) on behalf of the people of Scotland.

At the time of purchase, the plot also contained three sheds but the furniture from the cottage had been removed before Historic Scotland took possession.

Cottages with a similar character and history to Sunnybrae Cottage with their lime-washed walls and red or green corrugated roofs were very common throughout Scotland (Walker 1979a, Walker and McGregor 1998). Because they are so common they have been somewhat overlooked as having little architectural merit. Many have, over the years, fallen into disrepair with those in settlements inevitably being gutted of original features and extended to satisfy the requirements of modern living. This has also happened in rural areas, especially with the boom in holiday homes, but here a large number have also been demoted to use as outhouses and byres as the occupants moved away or built newer homes. The house next door to Sunnybrae Cottage on Larchwood Road is probably an example of a renovated house of this type. The map evidence shows an earlier building on exactly the same spot in the mid-19th century and it is likely that some of old masonry survives within the present footings (see Illus. 4).

Illus. 3 Pitlochry shown on the 1846 Faskally Estate Plan (McLagan)

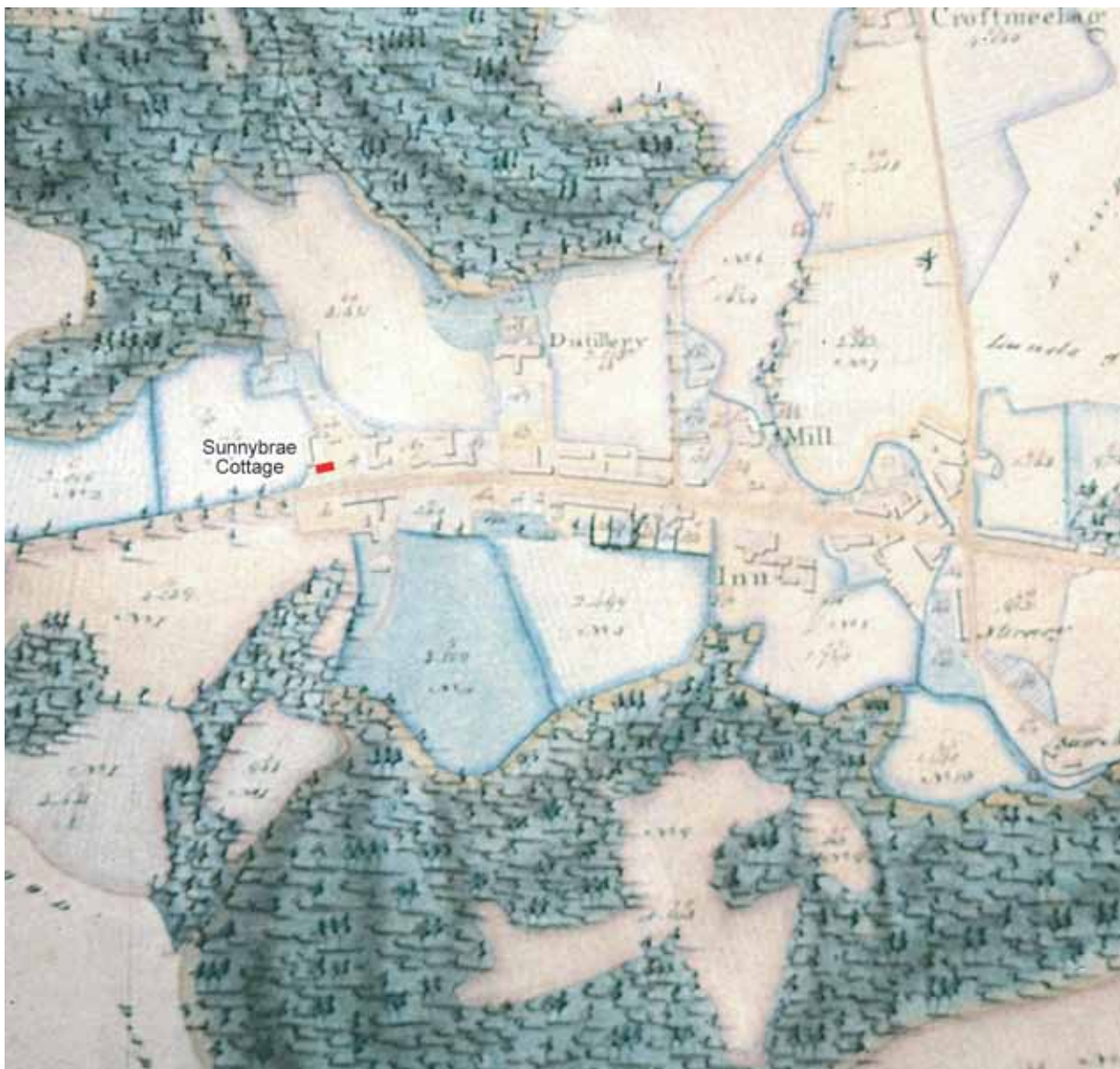

Illus. 4 The cottage lies at the junction of Atholl Road and Larchwood Road 1998 (Historic Scotland)



The perceived ordinariness of these houses has meant that few have been protected and in the present economic climate good examples are disappearing rapidly. The exceptional survival of the roof timbers and thatch make Sunnybrae Cottage of national significance and Historic Scotland was fortunate indeed to have the opportunity to acquire such an important vernacular building on the main road through Pitlochry.

1.1 Description of the building

Externally Sunnybrae Cottage was at first glance a somewhat anonymous gabled, single-storey cottage with a red painted corrugated-iron roof and white, formerly, light yellow ochre, lime-washed masonry walls on a base course of rounded river-washed boulders with an apparently modern extension to the rear (N). To the discerning viewer the house was of immediate interest. The combination of corrugated-iron roof and masonry walls set out in the form of a single-storey 'improved' farmhouse but lacking the exact symmetry of an improved house suggested the remodelling of a pre-improvement structure that had subsequently been saved from destruction at a later date by an utilitarian intervention.

In the late 1990s, a number of houses of this class had been examined and commented on in various publications. Full access was not always available but these publications gave some indication of what might be expected. Houses of this class in the original boundaries of Highland Perthshire included: Camserney Cottage, Drumdewan and Violet Cottage, all in the parish of Dull; Orchilmore in Blair Athol; Morlannich in Killin; and Lower Chamberbane in Strathtummel. All of these buildings incorporated a structure that appeared to

Illus. 5 The roof space 1998 (Historic Scotland)



predate the surviving building envelope. This structure involved the use of 'Celtic cuppill', a form of truss constructed using curved principal timbers.

From the 1960s, when these structural features were first recognised by Government agencies in Scotland, till the late 1990s these Celtic cuppill had been termed 'crucks'. This was a term coined in the mid 20th century to describe structures incorporating curved principal timbers but were centered on the Medieval cruck-frame. As a result, when 'Celtic cuppill' were described as 'crucks' they were dismissed by the Vernacular Architecture Group (of England) as inferior copies of the English cruck-frame and the reporters were accused of missing out crucial structural elements from the survey drawings. These 'crucial' elements translated as any form of diagonal bracing to stiffen the structure in a longitudinal direction. This turned out to be a feature of this type of structure as was the lack of a horizontal eaves-beam and to a lesser extent a horizontal sill-beam. It was at this stage that it was decided to change the terminology from 'cruck' to something more appropriate in Scotland. The Highland Folk Museum at Kingussie and Newtonmore used 'Highland couple' but work on the Scottish National Dictionaries (Walker 2005) established that the term 'cuppill' was the most widely accepted term in Scotland and that this type of construction survived in parts in all the regions of Europe at some time occupied by the Celts, the name was changed to 'Celtic cuppill' (Walker 2008).

Of the group of buildings originally identified as being of 'Celtic cuppill construction', Camserney Cottage is in the middle of a working farmyard and therefore unsuitable for visitors. Various steps were taken by

the National Museum of Antiquities of Scotland, now the Museum of Scotland, to purchase the building for moving to an open-air museum but this did not happen (Hay 1976). The importance of Drumdewan was not established until work on its renovation actually started (Walker 1979e). Violet Cottage was the first Celtic cuppill structure to be entered on the NMRS database but remained a private house (Dunbar 1956-1957). Orchilmore was on a working farm and was still in use as an outbuilding (Walker 1978). Morlannich was purchased by the National Trust for Scotland (Walker 1996: HS unpublished report), and Lower Chamberbane was at the bottom of a steep hill, close to the north shore of Loch Tummel and lacked an entrance road. It is understood that this has since returned to being a private house. At the time it was surveyed four different phases of occupation could be recognised even without archaeological investigation (Walker, 1985).

Returning to the Sunnybrae Cottage the sense of anticipation was heightened by the presence of a chimney head against a false chimney head at the west gable. This arrangement was known elsewhere in Scotland (Walker 1979 a&b) but only in photographs in Pitlochry and Killin, Perthshire (Walker 1979c).

On entering the house the bland internal decoration on the walls and ceilings masked most of the expected features, but the underside of the cuppill siles breaking the line of the wall/ceiling junction suggested that all

Illus. 6 Photo of exposed cuppill in W room (Historic Scotland)



had not been lost and on looking through the trapdoor into the roof-space the survival of the cuppill, roof tree, purlins, cabers and turf layers suggested the roof structure was almost intact. At this stage the decision was made to try to have the house purchased for the nation.

Returning to the building exterior, the main walls are constructed around two sets of Celtic cuppill which support a roof of pans (purlins), which in turn are supporting cabers running from wallhead to ridge tree. These cabers support the original thatched roof which had been cloued back in places to allow a softwood structure supporting corrugated-iron sheets to sit on top.

The E gable supports an integral chimney flue, which, from the exterior appears to be matched by a similar structure on the W gable. This, however, is a blind chimney, which, until recently, had a red brick flue built against its internal wall.

The front door faces S onto the Atholl Road and is flanked on either side by a single window. Access from the rear is provided by a door in the extension on the N wall and a single central window lights the central closet. At the time of purchase there were three sheds in the garden to the W of the house.

Internally the rectangular core of the house is divided by stud partition walls. In 1998, it was lined throughout with plasterboard and was provided with central heating

Illus. 7 Building recording in progress (Historic Scotland)



Illus. 8 The scaffolding shell

from a small gas-fired boiler sited in the wall between the extension and W room.

On entering the front door on the S side of the building there is a small entrance lobby. The door to the E end of the lobby leads into a bedroom; the door to the N a small closet/bedroom with an access hatch in the ceiling; the door to the W leads into the living room (previously the kitchen/living room). The floors were timber boarded, the walls painted magnolia and skirtings gloss white.

A door in the N side of the kitchen/living room leads to a scullery with a back door to the E and a bathroom to the W. The home was empty of furniture.

The only clue to the archaeological potential of the structure came when the hatch in the mid-closet was opened to expose the Celtic cuppilled structure linking purlins, with cabers supporting a turf and straw thatch. The whole of the attic space was soot blackened apart from some inserted sawn cuppills and the ceiling joists. This suggested a structure that was in use before the introduction of chimneys and it was this that encouraged Historic Scotland to purchase the property and commission the archaeological investigation.

Early maps of the area show what is now Larchwood Road to have been a narrow track (refer to Illus. 44 & 46). This has been widened along its length and at its S end it cuts into the slope and has been landscaped around its junction with Atholl Road. The present

appearance of the area is somewhat different to that of 100 years ago. The addition of a rear entrance to the N and the graded path from this down to Larchwood Road will have further altered the original curtilage of the property.

1.2 Strategy for the investigation

Sunnybrae Cottage is a typical vernacular building in that its form and construction has changed over the years to meet the changing aspirations and requirements of its inhabitants. This creates a complexity of physical evidence that is difficult to disentangle. Much of the surviving evidence, particularly from the early phase, is incomplete and interpretation is hampered by a scarcity of comparable archaeological work and a lack of a definitive published data on other Scottish vernacular buildings.

The earliest physical traces of the building were always going to be difficult to identify, so this project planned to trace the history of the building using a broad range of archaeological techniques. Accurate survey and detailed recording of the upstanding walls and the roof was undertaken as successively older layers were carefully peeled back. Wherever exposed, the solum was archaeologically excavated, as were critical areas outside of the building. Analysis of the materials used was undertaken including the thatch, the turf in the roof and at the wallhead, the timbers and the mortar. Any finds, including such things as floorcoverings, bricks, wallpaper and fragments of newspaper used as lining, were conserved and reported upon.

It was clear at the outset that the project would require a multi-disciplinary approach utilising in-house expertise, with help from external specialists and interest groups. Each phase of work was therefore reviewed by Historic Scotland and the relevant contractors and the results used to inform and direct the next phase. With one eye on the eventual presentation of the site to the public, duntakings were evaluated and were only undertaken where they potentially answered a specific research objective.

1.3 Archaeological fieldwork and analysis

The story of the investigation of the physical remains really starts in October 1998 with the first survey of a team of Historic Scotland Architectural Technicians. The cottage was recorded in detail by Historic Scotland photographers and they have continued to document any changes that have taken place since. Initial intrusive work comprised the exposure of the cruck-cuppill in the E room and a watching brief undertaken by Kirkdale Archaeology in advance of a proposed temporary shelter. This enabled Historic Scotland to assess the archaeological potential of the building and to determine how to proceed.

A programme of investigative works was then instigated, treating both the upstanding building and any ground works with equal rigor. Within the building itself, the only way to investigate the earlier fabric was to remove later layers. So the plasterboard, certain areas of the later timber lining, brick chimneybreast and floorboards were removed so that earlier timbers and masonry walls could be investigated in detail. The majority of this work was undertaken under strict archaeological supervision and a full record was taken. Any necessary duntakings to stabilise the building were also monitored. All significant features of the fabric of the building were numbered, described and their stratigraphic relationships recorded (Illus. 7).

Access to the roof was provided by scaffolding, and both the scaffolding and the whole building was protected from the elements by the construction of a temporary corrugated iron shelter (Illus. 8). This shelter remained in place from September 1999 until September 2003, and offered an excellent opportunity for controlled investigation with minimal destruction to the roof. Within this shelter it was possible to excavate and record selected areas through the thatch. Areas of the roof were

Illus. 9 Children from the local primary school offer some alternative interpretations 2000 (Historic Scotland)



cleared of loose debris and brushed back to reveal large areas of exposed turf, most of the original straw surface having been removed before the corrugated roof was put on.

In addition to the work on the building fabric a number of smaller areas were excavated both within the footprint of the building and at key points around the site. Thus the whole of the floor in the E room was cleaned and archaeologically recorded as were the main thresholds, key areas against the external wall, and an area to the W of the building. Here, it was thought, there might be potential to find the remains of external structures abutting or adjacent to the current building.

The fieldwork was carried out over several seasons between 1998 and 2005, with Historic Scotland undertaking any downtakings and survey and Headland Archaeology Ltd assisted by Dr Bruce Walker undertaking the archaeological recording and interpretation.

From 1998 until 2006, the following elements of work were undertaken: two watching briefs; three phases of recording and excavation; archival work; an oral history project (in conjunction with the Moulin and Pitlochry History Circle); dendrochronological analysis (A. Crone of AOC Ltd); analysis of the thatch and turf (Headland Archaeology Ltd), timber analysis (D Saville, Carpenter Oak & Woodland Co. Ltd); lime mortar analysis (Scottish Lime Centre); linoleum, wallpaper and newspaper analysis (Kirkcaldy Museum and Art Gallery and Allyson Dermott with input from the National Maritime Museum). Further non-destructive examination was made using, for example, a borescope and ongoing sampling and analysis of limewash, flooring samples (G Grant), newspaper samples and paint on the corrugated iron roof was undertaken by Historic Scotland Conservation Centre.

1.4 Interpretation and presentation

Although the investigation of Sunnybrae Cottage was conducted like an archaeological excavation even the oldest elements are unlikely to be more than several centuries old. With regard to the interpretation of the site there is therefore considerable scope for utilising sources of evidence that are usually not directly applicable to archaeological sites. These include:

- Comparison with similar structures in the locality and in the influencing regions
- Images of vernacular buildings, particularly interiors illustrated in the works of the Scottish genre painters operating from the last quarter of the 18th century to the first quarter of the 20th century
- Photographs taken from the mid-19th century onwards (Walker 1979b)
- Descriptions of buildings given by early travellers, estate factors, sanitary inspectors, lawyers, insurance companies and any other groups interested in housing conditions and housing standards

Much valuable information was provided by the local people and others who visited the site as work progressed (Illus. 9).

Few vernacular buildings in Scotland have been given the level of attention that Sunnybrae Cottage has received. The different analyses undertaken have generated large quantities of data that are as relevant to the interpretation of the building as the surviving masonry, timberwork or thatch. Detailed individual reports on the excavation and specialist analyses are available for consultation at the National Monuments Record of Scotland (NMRS). For the purposes of presenting the results here we have therefore tried to integrate the diverse strands of evidence to produce a more readable text. We have also taken this opportunity to expand upon broader issues relating to traditional building techniques that would have been a matter of common knowledge to people at the time but are now little known.

In the following chapters, the archaeological sequence for the site has been divided into five phases starting with the Highland house and ending with its most recent history since it came into care. The evidence for each phase is presented through detailed consideration of the main structural elements (walls, timberwork, roof etc) and what the evidence tells us about the materials used and methods of construction. This is then followed by a discussion of the implication of the results with some informed reconstructions designed to give an impression of what the house might have been like to live in. The final section will attempt to evaluate the process of archaeological recording and understanding applied at Sunnybrae Cottage.

2 HIGHLAND HOUSE – PHASE 1

(c. 18th century or earlier – stone footings, turf walls and timber cuppill structure)

2.0 Introduction

The early history of Sunnybrae Cottage is extremely difficult to illuminate. The documentary evidence is scant, even its original name is unknown and much of the early fabric of the building has been removed and replaced. The usual source for information on smaller buildings in the Scottish countryside is the Ordnance Survey Name books prepared by the surveyors working on the first edition of the Ordnance Survey. Unfortunately the Name books for Moulin Parish had been withdrawn from the main archive whilst the surveyors worked on some revised maps in the early 1940s. These were in the OS Headquarters in Southampton when the building was bombed and the Name books were destroyed. However, 19th century Name books for nearby parishes such as Rannoch, comment on the fact that there were no stone houses in that parish and that many of the houses were built of turf. This was probably the situation in Pitlochry before the tourism boom and is consistent with the evidence found at Sunnybrae Cottage.

The roof of the building is supported on a pair of Celtic cuppillars and this self supporting structure together with the extremely wide footings tends to suggest that the original walls were non load bearing turf and the current hypothesis is that the cottage, as constructed, was a simple, rectangular, turf building that probably predates the 19th century. It could in fact be much older but the evidence is lacking.

The Faskally Estate papers may one day reveal further details on its occupancy and when it was constructed. However, a well-known local tradition has this cottage as being the site of an 18th-century murder. As the story goes, Stewart of Bonskeid and his brother-in-law, Stewart of Shierglass, were among a group of men drinking in a house at the W end of Pitlochry. Here, each house is reputed to have had its store of illicit alcohol, and Bonskeid was stabbed in the chest by his friend during a petty brawl (Sandeman 1892). Certainly, Sunnybrae Cottage, was for some time, the last house on the main road W leaving Pitlochry but it is impossible to verify whether it was the scene of the crime or whether the story is factual.

Had the timber cuppillars been made of oak, dendrochronology (tree ring dating) may have helped to provide a construction date. However, at Sunnybrae the major timbers are of ash and there is currently no dendrochronological sequence available for this species in Scotland.

The sequence of construction indicates that the stone footings and the ash cuppillars are the oldest surviving parts of the building and were re-used in all later phases.

There is heavy sooting on roof timbers, wooden cabers and the lowest strata of thatch which, although they do not confirm a similar antiquity, clearly indicate that they originate from a time when the living space, and hearth, were open to the roof (Illus. 10a-d).

The locations of the doors and windows, if such existed, cannot be identified archaeologically and very little else definitely survives from this early phase. This is presumably because much of the building comprised degradable materials such as turf, wickerwork and wood that have only a limited useful life span. Because of the scarcity of evidence, the interpretation of these early remains rely very heavily on non-archaeological evidence such as written accounts and images of other buildings of similar status, from Perthshire and adjacent area. Sunnybrae Cottage too, probably began life as a turf structure.

2.1 Solum, foundation course and floors

The survey of the building indicated that the site for the cottage had been levelled before construction, by adopting a minimal cut and fill technique, accepting the existing ground surface at the SE corner as the level for the cut but excavating into the subsoil upslope to the W. The topsoil excavated was probably set aside for the regrading of ground immediately in front of the house. Subsoil was evidently retained for use in the core and mortar binding of the wall footings.

The W and N walls of the cottage sit directly on subsoil but the E end wall appears to sit on topsoil. The oldest fragments of wall comprise footings that stand to a height of no more than 0.9 m. They do not survive to their full width anywhere on site but can be projected to be over 1 m thick in places. The footings are formed of two faces of rounded field boulders separated by a core of sandy orange subsoil. These differ significantly in thickness from the upper parts of the wall which are formed of mortared masonry and belong to Phase 2 or 3 (Illus. 11 & 12). Inside the building the original boulders of the footings were removed wherever they projected into the room, presumably to accommodate the later lining of the walls with timber. Any areas of the loose subsoil core exposed at the time were consolidated with brick and mortar.

In all places investigated the natural subsoil lay directly beneath the floorboards with only occasional patches of compaction and trampled building debris attributable to 19th-century renovation works. No evidence for earlier floors, hearths or thresholds were recovered. Clearly the level of the solum had been lowered throughout to accommodate

Illus. 10

a) Phase 1-2 Longitudinal section showing N internal wall (Historic Scotland)

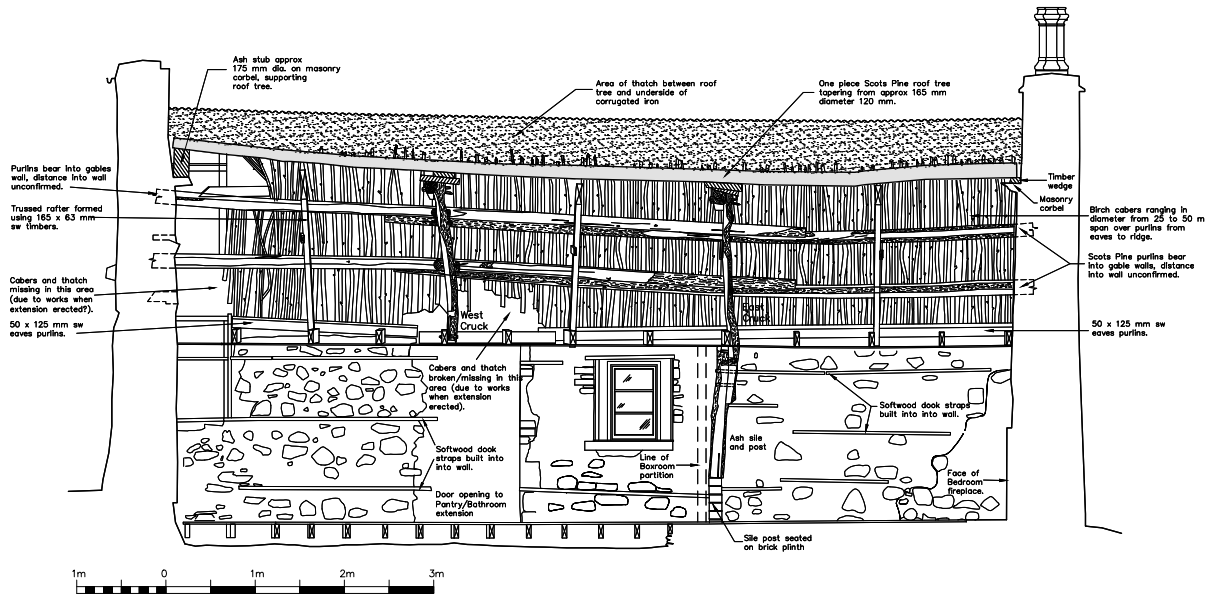

b) Phase 1-2 Longitudinal section showing S internal wall (Historic Scotland)

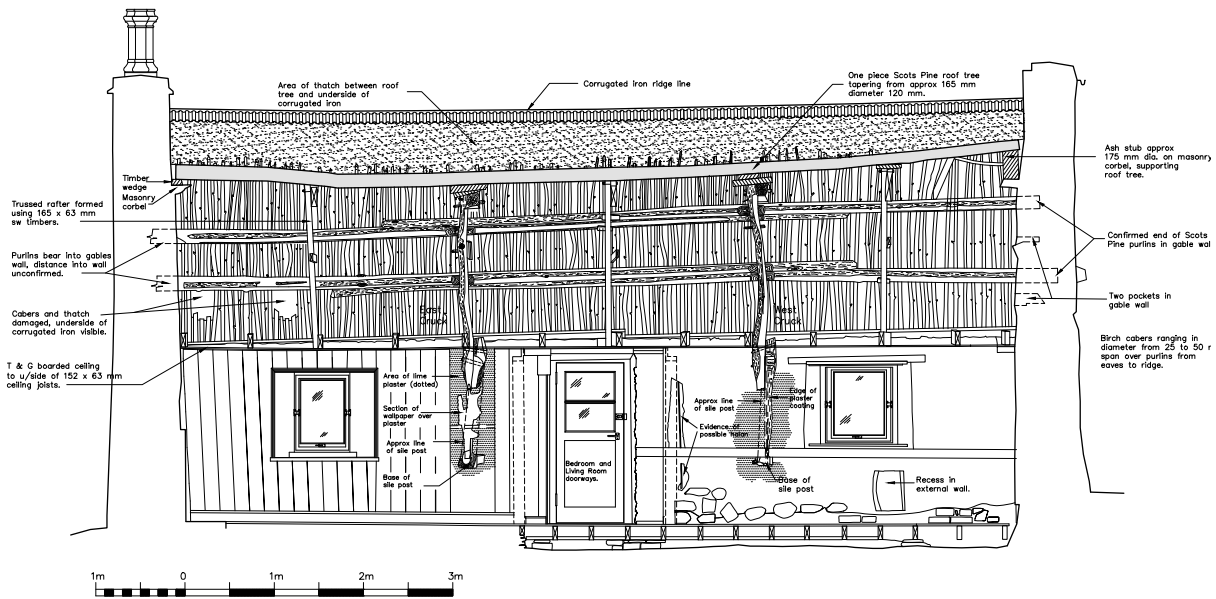

c) Phase 1-2 Cross section and elevation. – W wall (Historic Scotland)

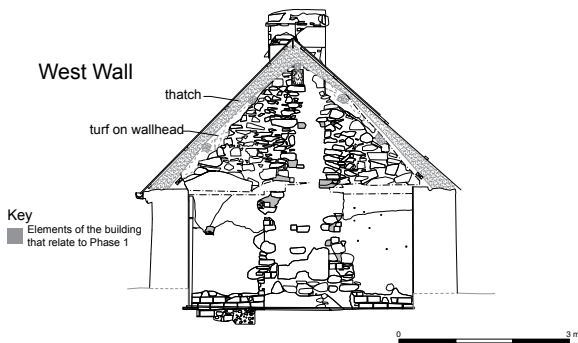

d) Phase 1-2 Cross section and elevation. – E wall (Historic Scotland)

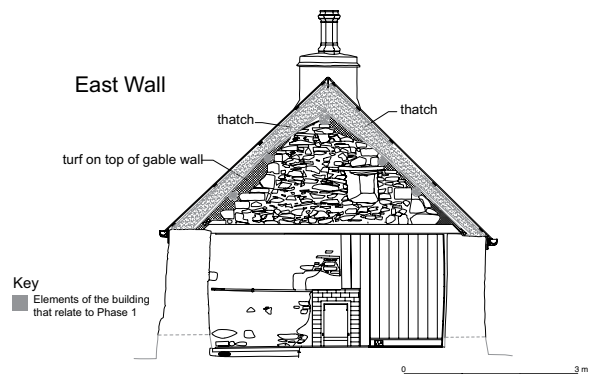

Illus. 11 The W gable wall showing an area of exposed wall core is formed of orange subsoil and has been raked out and replaced with brickwork wherever it remained exposed (Historic Scotland)



the insertion of a suspended timber floor while maintaining headroom in the newly renovated rooms.

In the absence of direct evidence for a prepared surface, an earthen floor, possibly utilising a tempered version of the subsoil, would have been the expected surface during the first phase of occupation. Such floors were commonly prepared through ‘puddling’ by foot (e.g. Hutcheson 1927) or by stalling animals within the walls to trample down and level the uneven floor.

Foundation walls/footings

The field boulders would have been collected locally and once sufficient were brought to the site, an earth mortar would have been prepared. This was often basically just a subsoil but if the ground was sandy or gravelly it may have been tempered with clay and silt, or, if clayey, tempered with sand and gravel. The ideal was to produce a mortar that when set was similar in matrix to a building sandstone. Large stones were removed and the mix was “knocked up” by turning and treading it to make it more plastic or workable. Masons described mortar in this state as “buttery”. These earth mortars tend to be stiffer and heavier than the cement mortars used today. Lime mortars were not used in this class of building until the mid-20th century.

Illus. 12 A sample section through the N wall showing the wall core of the original footings (MM). The lack of structural bonding in the wall indicates that this is what was known in Scotland as ‘clay wall’ which is gradually introduced in the last years of the 18th century (Walker 1992).

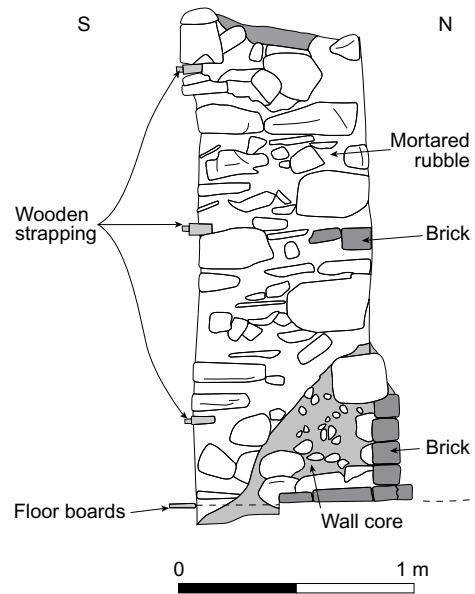

2.2 Timber structure

The majority of the surviving, structural timber clearly predates the 20th century and comprises two ash Celtic cuppills supporting straight, predominantly softwood timbers; the ridge pole or roof tree and purlins or pans. These, in turn, support numerous close-set, small-diameter birch and pine cabers which run from apex to eaves. The ridge pole and purlins are currently supported at their ends by the gable wall. There is nothing in the structure to suggest a hipped roof at any time in the past.

Celtic cuppill

The term ‘cruck’ does not appear in the Scottish language but in England it is applied to principal structural timbers that are crooked or curved. The Scottish term for such a structural element is a ‘sile’ and these were ‘knitted’ together to form a ‘cuppill’. Throughout this publication the term Celtic cuppill has been used to describe a building cuppill formed of a pair of curved timbers. These are generally joined in the roof space by a series of collars and, once anchored from below, these provide the load-bearing support for the cabers and coverings of the roof. In the system, the walls themselves do not have to take the weight of the roof allowing materials such as wattle and daub and turf to be used and periodically replaced.

The curved timbers that form the Celtic cuppills can be made of a single timber. However, as at Sunnybrae Cottage, most examples used jointed timbers made from a lower post and the upper blade (refer to Illus. 13 & 14). This allows shorter lengths of timbers to be used whilst providing more headroom in the rooms.

The earliest use of the term cuppill is recorded in Dictionary of the Older Scottish Tongue (Craigie *et al.* 2002) in 1420, but the building techniques seems to be a Celtic innovation. It may also be related to the Saxon halls of Northern Europe and to the Viking Migration Period house.

Basically the technique is hundreds of years older than the ‘cruck frame’. It is a technique that relies on the ‘eye’ and skills of the wright and can be adapted to undulating sites, steep slopes, etc. The resultant buildings are built to ‘running levels’. There is no sill beam, no eaves beam or wall plate; the structure is not ‘framed’ or ‘braced’ in the usual sense: stability is obtained by careful positioning of the ‘cuppill’ either by the use of a ‘parallelogram plan’ or by slightly angling the ‘cuppill’ in a way that is barely discernable. The earliest ‘cuppill’ utilise ‘clasped’ pegged joints, rather than the much later mortise and tenon, and the whole structure is organic and flexible rather than squared off and rigid.

The cuppill are almost certainly original components of the building but it is also probable the other soot-blackened timbers are also of considerable antiquity. Some timbers have clearly been shifted or realigned periodically when alterations to the roof or gable walls were undertaken. The smaller diameter wood in the roof is heavily wormed but the larger timbers are in a surprisingly good condition, partially because of the tar and soot deposited through years of heavy smoke penetration through the roof space.

The cuppill divide the building into three bays each approximately 10 ft long (i.e. just over 3 m) and are formed by a pair of jointed blades (Illus. 13, 14, 15 & 16). Only three of the cruck blades remain intact, the basal timber (sometimes called the wall post) of the NW blade was removed when the kitchen door was slapped through the N wall. It currently sits on a steel support. The base of the two in the S wall lie within the thickness of the wall but the lower part of the NE blade stands proud and presently sits on a brick plinth. This timber must only have been exposed when the N wall was reduced in thickness during Phase 3. The base of this post, and probably also the other wall posts, sits at the same level as the stone footings.

At Sunnybrae Cottage the carpenters were evidently aware of the shortcomings of ash when exposed to damp and took appropriate steps to keep the base of the cuppill dry. Many other early cuppilled buildings in the area and further N into Inverness-shire were originally earth-fast at the base and as the timber rotted, were cut back and underpinned with either masonry or brick.

The use of cuppill in the Highlands was well known at one time. In a study of pre-1800 houses Hutcheson (1927) could almost be describing Sunnybrae Cottage:

‘The roof was formed usually of two cuppill, each composed of two trees having a natural bend to suit the slope of the roof, set at the foot on a stone placed in the side walls about two feet above the floor, the upper ends crossing each other at the ridge, like the upper part of the letter X, and secured together by a stout wooden pin. In this hollow was placed the ridge pole, known as the “roof-tree” long enough to stretch the whole length of the building and rest at the ends on the gables which were also of turf. The cuppill were, moreover, secured together by a stout baulk of timber a little above the wallhead. Resting upon and stretching between the cuppill and the gables were laid lighter branches, called purlins, which in turn had a coating of still lighter twigs laid up and down between the wall heads and the ridge, and upon these, turfs were laid in the manner of slates, the whole being covered with thatch of straw, rushes (Scots rashies) heather or ferns. The gables and ridge were loaded with thick turfs taken whence the best matted roots were to be found...’

The ash cuppill were formed from a single timber (Illus. 17) sawn along its length to produce the opposing timbers in each pair. The round sections of the cuppill are not, however, full halves indicating that the middle section was used elsewhere, perhaps in the collars. The saw marks on the cut surface indicate pit-sawing while the circumference has been clawed off with an axe leaving the bark in places.

Below wallhead height the timbers have been roughly squared and axing marks are visible in places. The top of the cruck posts are approximately level with the present wallhead and are joined to the upper part of the cuppill by a crude lapped joint with face-to-face pegging (Illus. 18). Gaps are present in the junction, possibly a result of shrinkage. The pegs are 1¼ ins (32 mm) square and of ash or oak and utilise splayed holes (as opposed to drilled holes) which offers greater resistance to the pulling apart of the jointed faces.

The blades are joined at the apex by a relatively short collar or yoke (Illus. 19) making a saddle into which the pine ridge timber (roof tree) sits. In the yokes the ridge is levelled by the use of pine wedges. At the E gable it is supported directly by a stone corbel, while at the W end a short length of round timber sits between the corbel and ridge (see Illus. 10a & 10b). This suggests that the original roof-tree was carefully cut to fit the turf walled structure and not the masonry one. The turf walls would have probably projected further into the interior particularly if there was a secondary timber structure with caber or stake-and-rice inner face.

Illus. 13 Details of the W cuppill (HS)

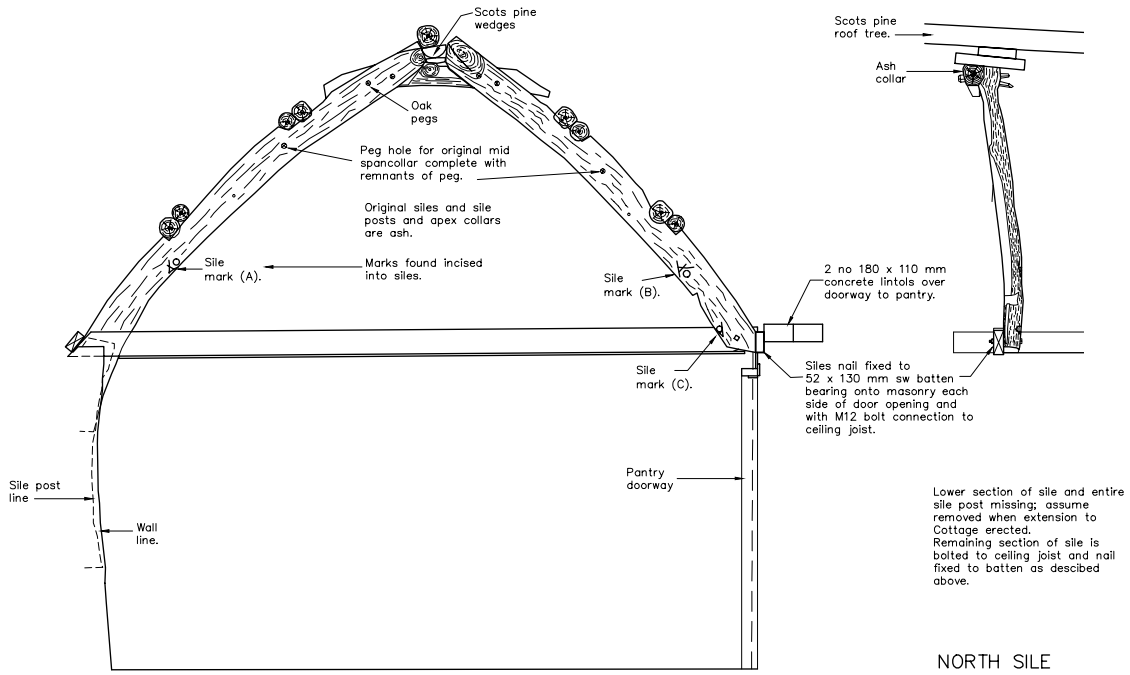

EAST FACE

NORTH SILE

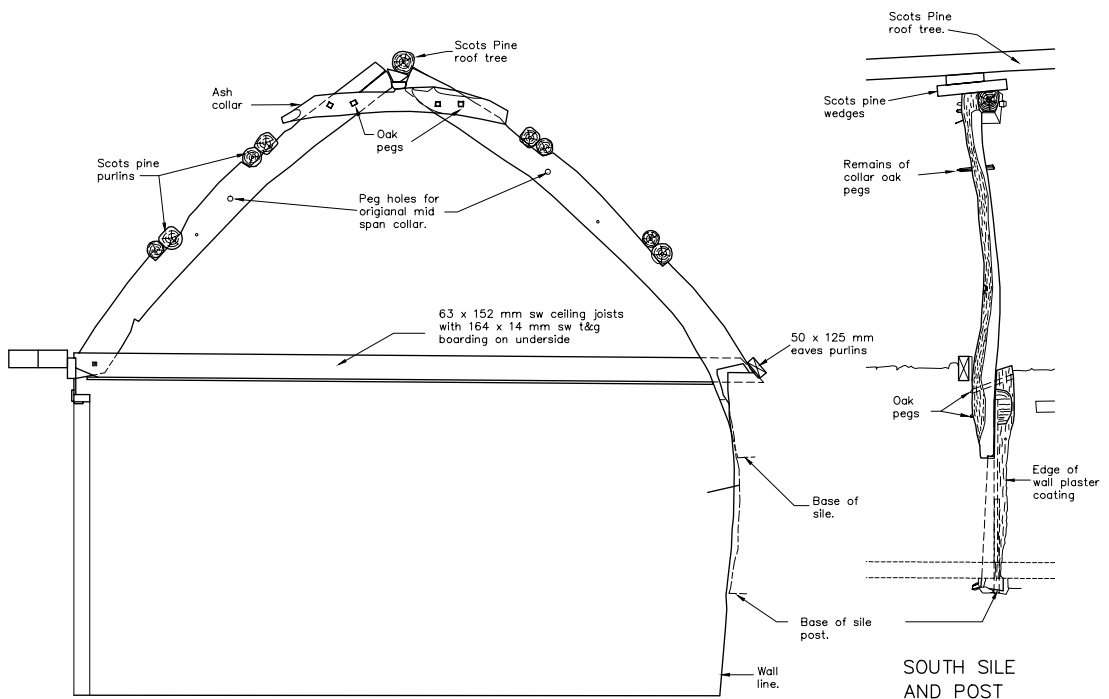

WEST FACE

SOUTH SILE AND POST

ELEVATIONAL SECTIONS OF WEST CUPPILL



Illus. 14 Details of the E cuppill (HS)

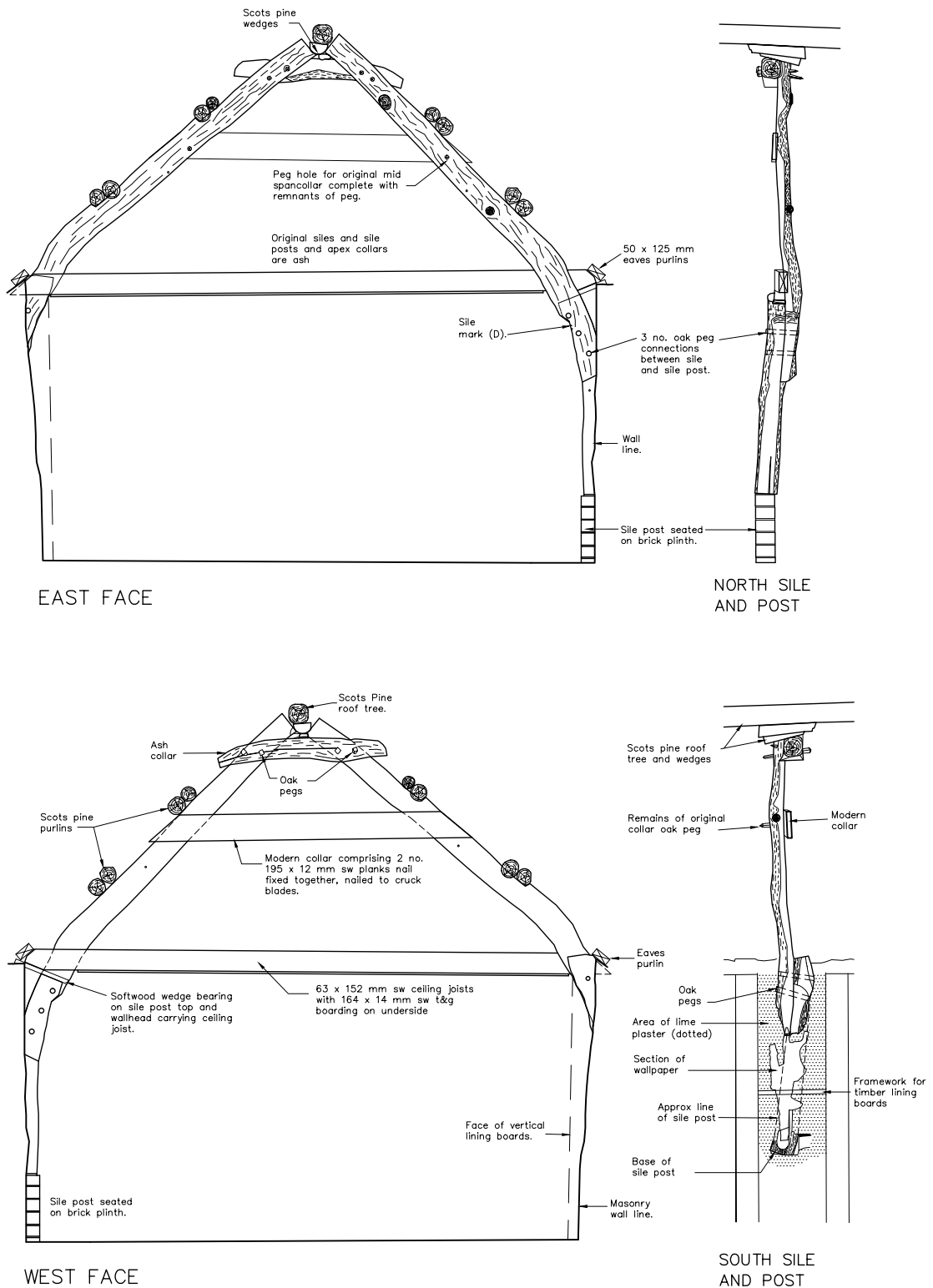

ELEVATIONAL SECTIONS OF EAST CUPPILL



Illus. 15 Exposed cuppill post and joint in N wall of E room (Historic Scotland)



Illus. 16 The apex of the W face of the W cuppill showing the pegging (Historic Scotland)



Illus. 17 Selecting the timber (BW)

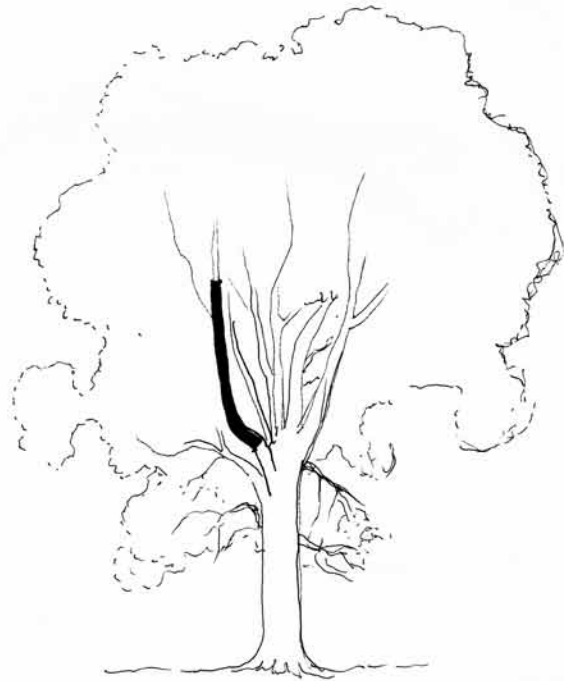

A. from a standard tree

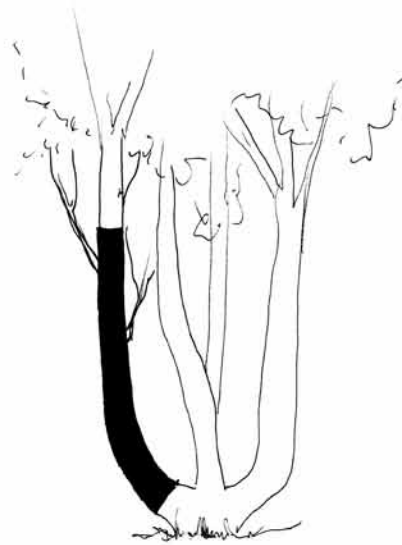

B. from a coppiced tree

Part way down the blades are a series of redundant peg holes and soot shadows indicating that there was originally a second collar joining the blades. The position of the pegs and shadow indicate that, for the W cuppill at least, the mid-collar was not straight (Illus. 20).

Pine purlins rest on the outer face of the cuppill siles where rough housings have been cut for them. They have been kept at a full usable length each overshooting two full bays and providing doubled-up purlins at their thinnest tapering ends over the middle bay. Between the purlins, running down the pitch are a series of closely-set and heavily wormed birch and pine cabers ranging from 20 – 70 mm in diameter.

Illus. 18 Lapped joint with face-to-face pegging forming a clasped joint due to the pegs being angled (BW)

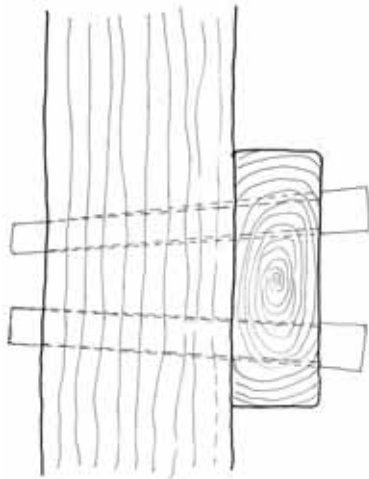

Illus. 19 Details of pegging on the E face of the E cuppill (Historic Scotland)



Illus. 20 Inferred mid-collar form (BW)

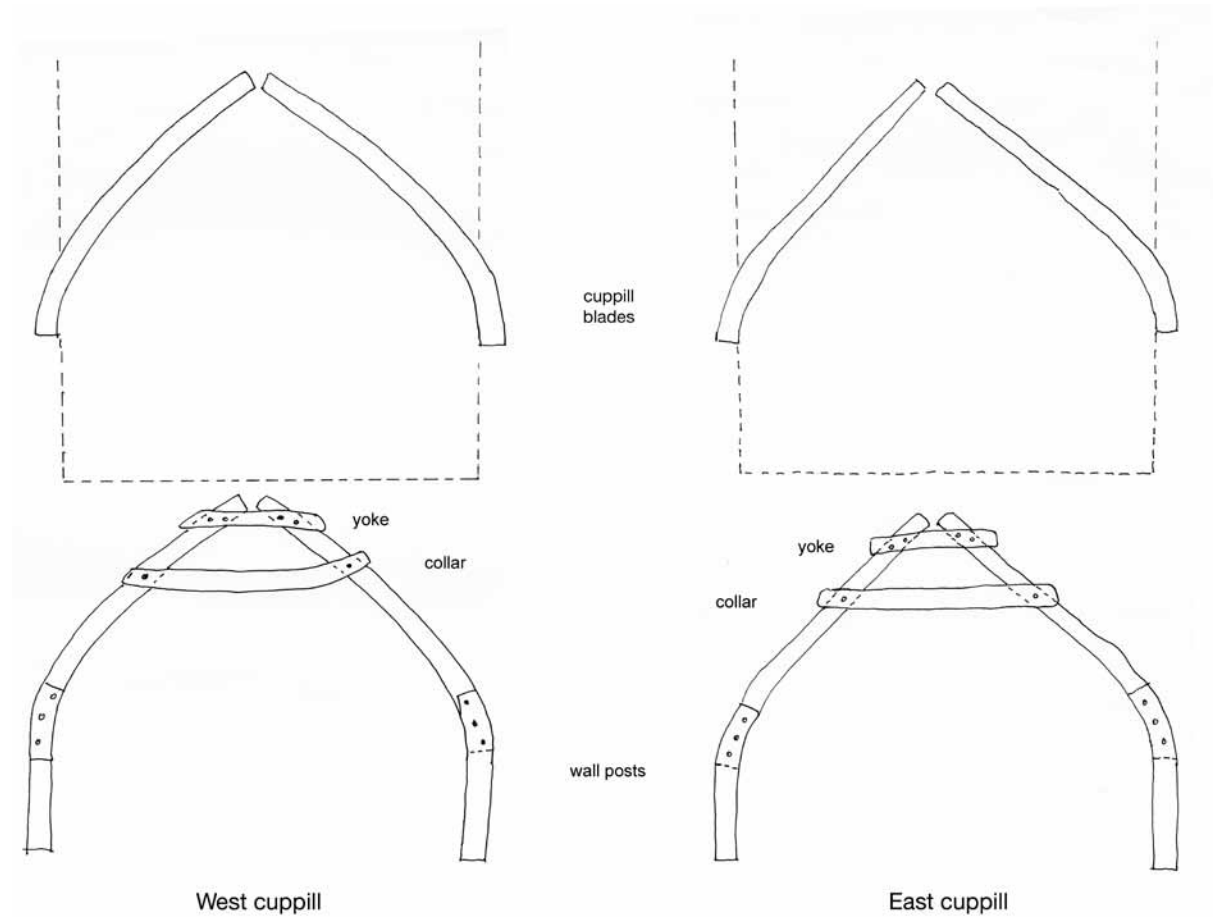

A series of carved 'marks' in the timbers survive well on the siles (Illus. 21 & 22). The marks may have been used to help in setting out the cuppill but they would usually be found on the flat face and are only present on the sile. It is perhaps more likely that the marks were made

by the forester or pit sawyer to identify the timbers or matching pairs. The 'A' may indicate that the timbers had been selected for making of cuppill or they could have been a sourcing or carpentry mark.

Illus. 21 Timber marks (LP)

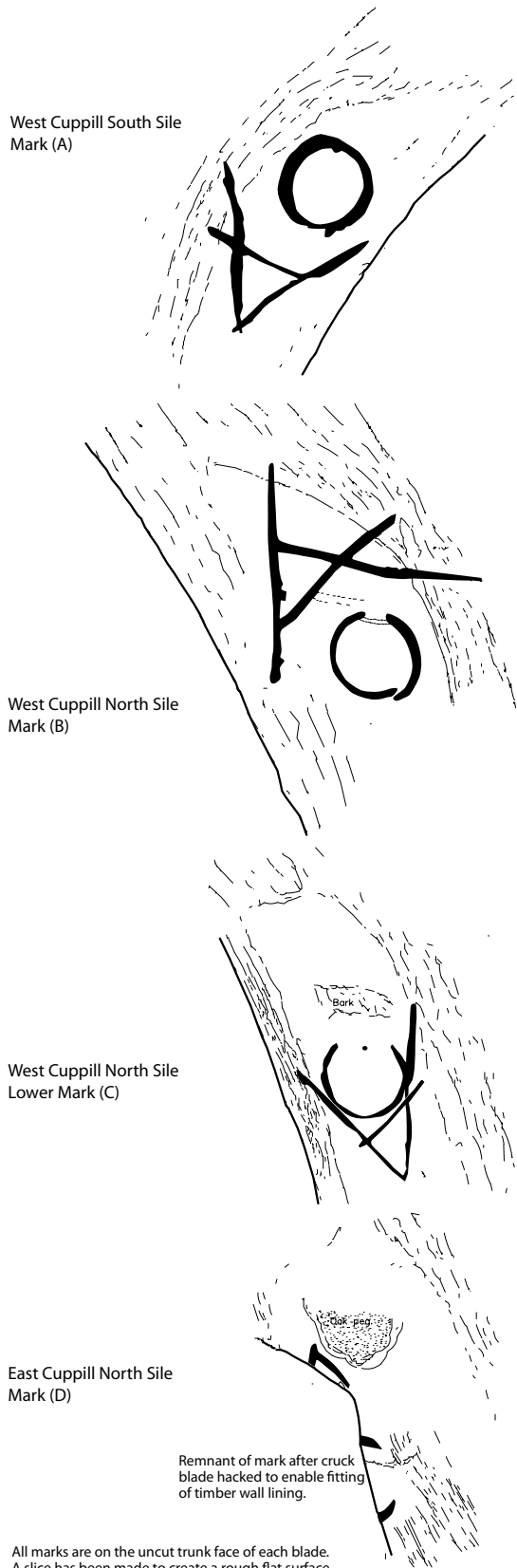

All marks are on the uncut trunk face of each blade. A slice has been made to create a rough flat surface into which the marks are incised.

Read this drawing in conjunction with drawings entitled Elevational Sections of East and West Crucks

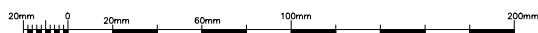

Illus. 22 Detail of timber marks – W Cuppill, N sile (Historic Scotland)



The date of the cuppill could potentially provide an age for the building, so samples for dendrochronology were taken from both the siles and collars. These were compared with samples from four sources of long-lived ash from the region but none were able to provide a tree-ring sequence of sufficient length to date the Sunnybrae Cottage cuppill. In spite of this, the pattern of growth rings and the form of the bark on the different timbers showed them to have had two different patterns of growth.

Group 1 – the siles and collar of the W cuppill, the NE cuppill post, the post on the corbel in the W gable

Group 2 – the blades of the E cuppill, the lintel over the loft window (E gable)

The two groups had evidently grown at different times or in different locations. It is possible that the timber came from managed copses but when ash reaches a certain age it begins to shed large boughs and would have been used when available. Timbers obtained in this opportunistic way are very likely to have grown differently and may explain the observations of the dendrochronologist.

The diameters of the pine roof tree and purlins were too small to provide a dendrochronological date. This aside, the rings of the small diameter cabers were able to show that, at the time of cutting, they were between 6 and 27 years of age. Such a broad range makes it unlikely that they were taken from a managed coppice. The cabers would be classified as ‘wood’ and could be collected by the tenant as required.

Dendrochronology

Dendrochronology is the study of tree rings in order to provide accurate dates for historic timbers. In the temperate zone, the annual cycle of spring and summer growth and winter dormancy produce a sequence of rings, one for each year, that can be seen in the cross-section of a felled tree or a core taken through a timber. In a good year, tree growth tends to be more rapid and the tree rings tend to be wider. In years where poor weather, drought or other environmental conditions restrict growth tree rings tend to be narrower. By measuring the width of consecutive rings a sequence can be constructed that can be compared with previously developed tree-ring chronologies taken from old timbers of known date. The more rings the dendrochronologist is able to measure the more accurate the date produced, but they generally like to work with more than 100 in order to provide the unique sequence of ring widths required for an accurate date. The most commonly used species used for dendrochronology in Europe is oak and, if the bark or sap wood is present, the chances of obtaining a reliable date for felling are good. Unfortunately the main timbers at Sunnybrae Cottage were ash and, although a search was made of long-lived ash trees in the area it was not possible to establish the required master sequence with which we could have compared the Sunnybrae Cottage sequence.

Pit Sawing

It is likely that the cuppills at Sunnybrae Cottage were cut using a framed pit saw. Primarily pit saws were designed for ripping, that is, cutting with the grain (Illus. 23, 24, 25, 26, 27). Originally these were framed to tension the blade. The blade could then be lighter since it was held between the stretchers of the frame. Steel making improvements in the 17th century resulted in an unframed blade strong enough to be used without the effect of the stretchers. These blades were wider, resulting in a straighter cut and their sheer weight helped the teeth bite into the wood. The move from framed to unframed pit saws was far from immediate and both types of saw were in common use in 19th-century Britain and even today framed pit saws are still commonly used in countries like Romania.

Construction of the timber structure (Illus. 28)

Cuppills were set out within a rectangle the width of the proposed building. The irregular siles were then placed to fit as closely as possible to the span and desired roof pitch and the yoke, collar and wall posts were positioned on the siles. These were then bored and pegged, not at right angles to the faces but at varied angles to form a clasped joint. Faceted wooden pegs were then driven through the bored holes. The sharp angles of these pegs cut into the sides of the holes to prevent any rotation. The completed cuppills were then placed on the stone footings and raised into place. These were guyed temporarily while the purlins and other timberwork was completed.

When all the jointing was completed the completed cuppill was usually moved into place on the footings and raised into position to be held by guy ropes until the roof tree and purlins were positioned and fixed. This held the structure in position but it was not completely stable like the English timber frame. Instead, it relied on the angles that the cuppills were set at when forming the timber structure and surrounding walls working in harmony to resist external forces. The side walls were particularly important in resisting wind pressure applied to the gables. Originally cabers may also have formed the inner skin of the turf walls, although early descriptions normally suggest a “creel” finish internally, suggesting the use of “stake-and-rice” on the vertical surfaces.

The purlins would be placed over the siles and housings were cut with an axe, as required, to ensure that the purlins ran in a straight line and gave a suitable bearing for the cabers. The roof tree was then positioned and either stooled or wedged to provide a suitable line. This system depends on overall dimensions and the eye of the carpenter, rather than the use of squared edges and accurate measurement.

Illus. 23 An unframed pit saw (BW)

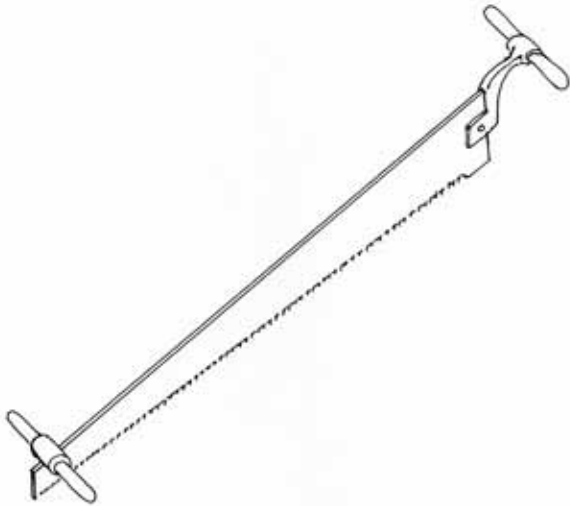

Illus. 24 A framed pit saw (BW)



Illus. 25 Sawing on a saw horse (BW)



Illus. 26 Pit sawing on a trestle or in a pit (BW)



Illus. 27 How timber was sawn a) a log, b) with sides axed away, c) two rip saw cuts producing 2 sile blades and a central section that could be used elsewhere (BW)

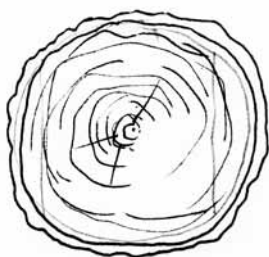

a

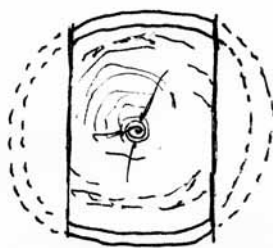

b

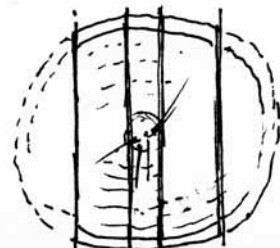

c

2.3 Turf walls

There is no reason to believe that the low foundation wall was ever any higher than it is today. In a Scottish context the wide footings and timber cuppills both suggest that the upper parts of the walls were originally constructed using an earth wall technique, the most common of which would utilise turf as the main component. This theory is supported by evidence from the Statistical Account of Scotland published in the late 18th century where a number of parishes in Highland Perthshire are described as being devoid of stone houses, the populace being housed in Highland huts or cabins built of turf or ‘stake and rice’ (wattle). The Ordnance Survey Name books of the Highlands in the mid-19th century also list a great number of parishes where there were still no stone houses.

Hutcheson (1927) graphically describes how turf was used in the construction of a typical Highland house:

Illus. 28 Suggested construction sequence for Phase 1

a) The site is cleared and levelled (BW)



b) The footings are formed of boulders with a subsoil core (BW)

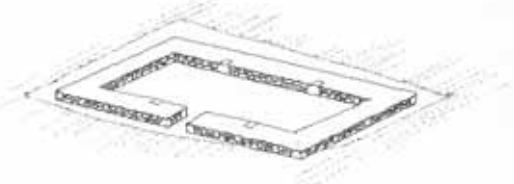

c) The cuppills are guyed temporarily while the purlins and other timberwork are fixed (BW)

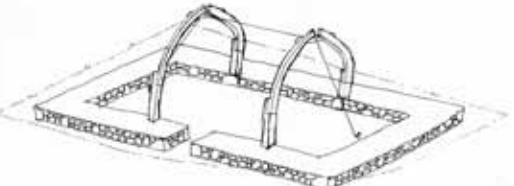

d) The roof tree is added and the lining for the turf walls erected (BW)

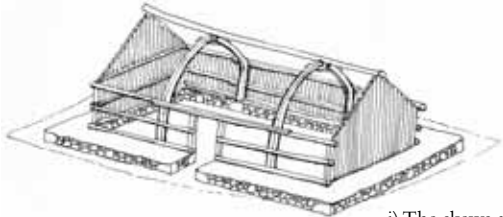

i) The skews are build up with turf to complete the roof (BW)



‘turfs and sods were used for the walls – feal and divots it was commonly called....The walls were made solid all the way round the house: the door and window openings being cut out after the walls were solidified.....The door was so low that even an ordinary sized person could not enter without stooping....’

The type of turf used and the bonding pattern adopted is open to speculation since no archaeological evidence survives other than the wide foundation course. The range of techniques for building in earth is, however, extremely wide as discussed in detail by Walker et al. (1996b, 2006). One possible solution is offered in Illus. 36).

The rounded cobbles at the base and larger corner stones would have both supported and protected the more fragile wall above. The timbers of the cuppills would typically sit on a substantial stone, on, or within, the wall but this cannot be confirmed at Sunnybrae Cottage because it was not possible to dismantle the walls around any of the cuppill bases.

e) Purlins are added the lining erected throughout with either cabers or wattle (BW)

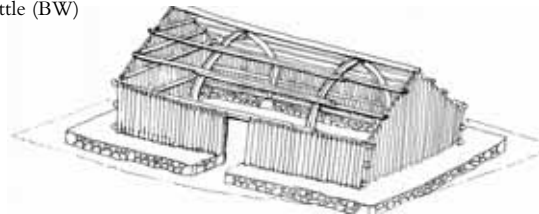

f) The turf walls are constructed and cabers of roof added (BW)

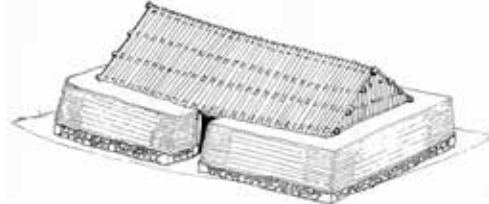

g) The gable walls are constructed and the canopy chimney erected (BW)

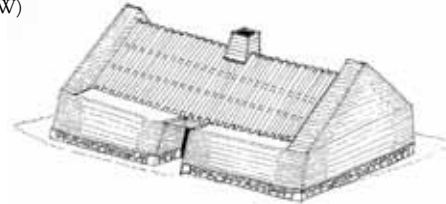

h) The thatch is put on with a ridge of turf (BW)



Earth walls

Throughout the known history of the turf building in Scotland, starting with the Romans and ending with the 21st-century golf course builders, the preferred type of turf was a clay turf followed by peat and sandy turf. Turf from rich arable land which composted very readily was avoided. The fact that turf was widely used is testified by the number of words for different sizes and shapes of turf to be found in the Scottish National Dictionary (Grant and Murrison 1929-1976) and the Dictionary of the Older Scottish Tongue (Craigie, Aitken *et al.* 1931-2002) (Walker 2005).

Towards the end of the turf building era in Scotland, that is, the early years of the 19th century, new turf buildings were being reported as failing after about five years. This does not give a fair impression of the stability and usefulness of this material since these reports were coming from areas where there had been a sudden increase in population combined with an effort to improve farming practices. This in turn created a bigger demand for turf for building and as a result good building turf became difficult to source. Many people turned to pasture land and it was this fertile loam turf that composted in the wall and created the poor impression with external reporters. More informed observers reckoned on 150 years with reasonable maintenance before rebuilding became necessary but much would depend on the quality of the original turf and the skill of the builders (Dinnie 1885).

Illus. 29 Different styles of turf bonding a) fale - wide shallow cut, b) fale - narrow deep cut, c) fale - wide shallow cut and divet, d) fale - narrow deep cut and divet, e) alternating stone and turf (BW). The left jamb in each sample is built using divet.

a) fale - wide shallow cut

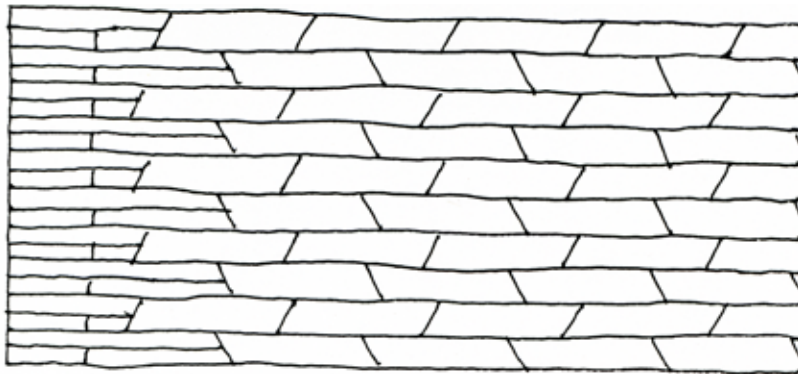

b) fale - narrow deep cut

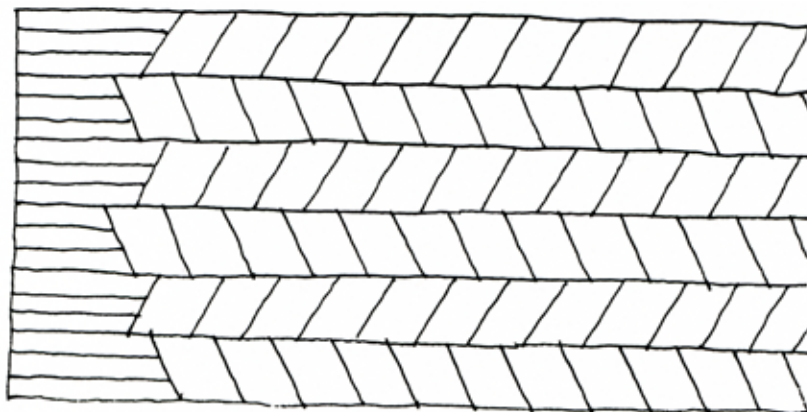

c) fale - wide shallow cut and divet



d) fale – narrow deep cut and divet

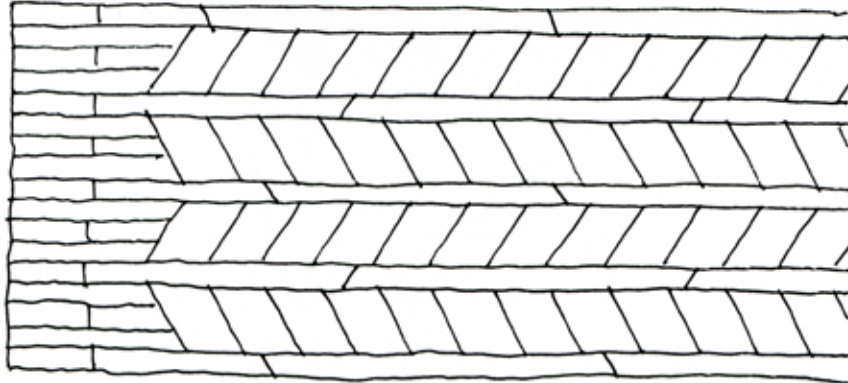

e) Alternating stone and turf. Flattish stones were preferred but any type of stone was used, usually field clearance boulders.

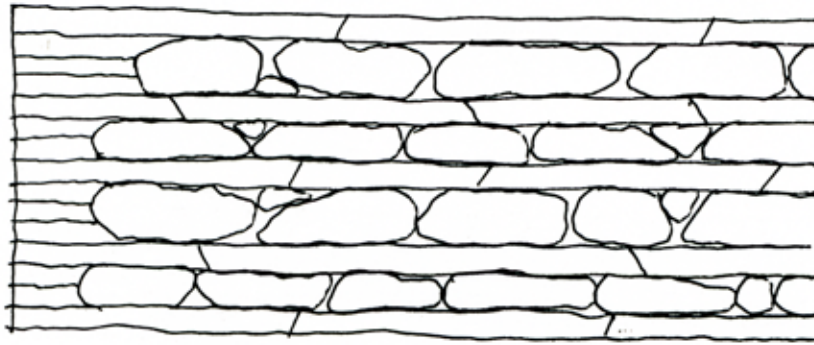

Fale and divet

By far the commonest expression for turf used in building was 'fale and divet'. 'Fale' is a parallelogram shaped block and 'divet' a thin rectangular slab (Illus. 29). Care must be taken when using archival sources since although the terms are standard local perceptions, as to what is meant by the terms vary as does the standard of building.

Stake and rice

Stake and rice is commonly referred to in documentary sources and is the Scottish term for wattlework. On external walls one use was as an inner surface of wattle against which turf was built. This inner surface of wattle had one main function, that is, to protect the inner surface of the wall from erosion through the rubbing of cattle or people on the dry surface of the turf. The exterior was normally paired with a sharp spade to provide an even surface that would shed water quickly and efficiently. This reduced the chance of vegetation establishing in the walls and the gradual changing of the material from a structural unit to a weak fertile loam which would crumble and fall as the turves composted.

Alternating stone and turf

An alternative to the entirely turf wall is the 'alternating stone and turf' wall using stones in place of the fale (see Illus. 29). The presence of the stones improves the wearing properties of the wall and the fale or divet used in place of mortar accommodates the irregularities without the need to employ a skilled mason. The best results are achieved when each layer of stones is sized vertically and any irregularities are packed out with clods or an earthen mix before the next layer is added.

2.4 Thatched roof

From the loft space it was evident that a proportion of the thatch had survived until the present day beneath the current corrugated iron covering. Up to 0.4 m deep in places and formed primarily of turf and cereal straw, it had been left to insulate against heat, noise and draught.

Illus. 30 Straw and turf exposed at the surface after cleaning (Historic Scotland)



Illus. 31 An excavated section through the thatch (Historic Scotland)



Excavated sections through the thatch revealed how the roof had been thatched (Illus. 30, 31 & 32). The two lowest courses, at the eaves, were formed by twigs of broom. These would have provided extra strength against wind, bird and vermin damage at this vulnerable point of the roof. Subsequent courses comprised alternating layers of turf and rye straw (Table 1).

Table 1 – Plant materials used on the roof

Material	Use	Comments
Rye straw – (<i>Secale cereale</i>)	Main body of the thatch	Rye is a long straw and the majority of the culm would have been exposed at the surface of the thatch. The straw had been threshed and cleaned of weeds.
Broom – (<i>Sarothamnus scoparius</i>)	Strengthening at ridge and eaves. Possibly also used as a top dressing at one point	Sprigs of broom were cut with an axe or similar tool.
Bracken – (<i>Pteridium aquilinum</i>)	Repairs to ridge	A thin layer of bracken fronds had been spread over the ridge as a repair to the ridge.
Oat straw (<i>Avena sativa</i>)	Repairs	Tippets of oat were used in some of the later repairs.

Illus. 32 The thatch of the S pitch in section (MM)

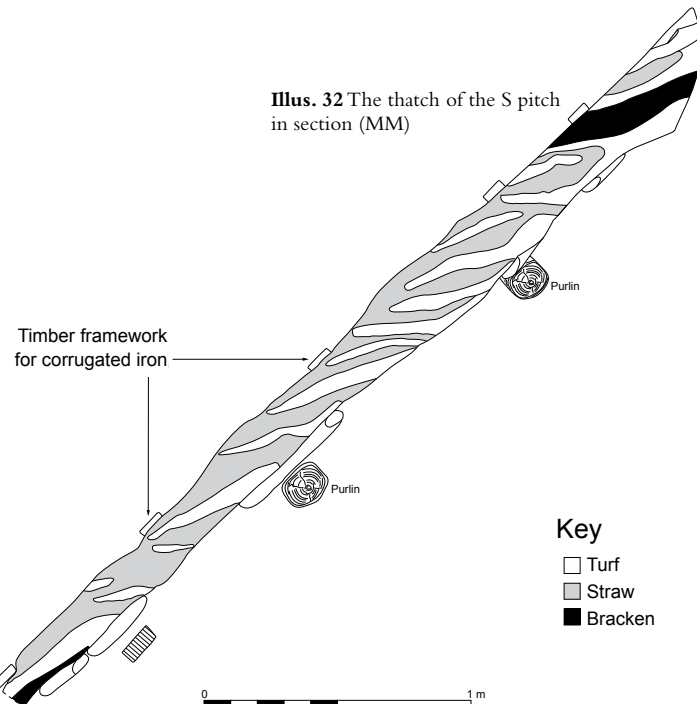

The straw used in the thatch was prepared by forming handful-sized bundles which were twisted over at the flowering end to form what is known as a tippet or grip. Courses of these were then fixed in position by turves placed vegetation-side down (Illus. 33). The weight of the turf would have held the straw firmly in place but additional fixing in the form of roping may also have been used, particularly to hold down the straw at the eaves and skewers. The ropes may have been secured by timber wands and pegs on the outer surface, or with a fixing hidden under the tail ends of the bundles above.

Repairs to the thatch were undertaken using tippets of rye or oat and sprigs of broom pushed through from the outside, sometimes under turves and sometimes through them. The cereal straw in these types of repair was usually introduced by the use of a stob, a long forked tool used to push the tippets into the pre-existing thatch. The large number of broom twigs would suggest a top dressing of broom over the roof at some point. This is consistent with Scottish thatching in the 19th century, where patching was carried out using whatever material was available at the time.

At the apex, another vulnerable part of the roof, a layer of broom twigs, their sharpened ends projecting several centimetres over the ridge, was held in position by turves. Additional layers of straw and bracken held by further turves had also been added. Repeated repairs like this resulted in a depth of over 0.4 m of turf over the ridge even in its current degraded and compressed state (Illus. 34 & 35).

Botanical and soil thin section analyses show that the thatching turves were cut from an area of heavily grazed pasture or from a previously stripped piece of ground with first or second years regenerative growth. This type of

pasture would have been typical of many areas of the valley floor around Pitlochry prior to the advent of liming and re-seeding of grazing land.

The turves used on the roof (*scraw*) were decidedly convex in cross-section (commonly 0.75 x 0.5 m and 3 – 4 cm thick) indicating the use of a specialised turf-cutting spade often called a flauchter (Walker 2006). Turf plays an important part in the formation of many types of thatched roof. It is a very common sub-stratum with the thatching material laid on this surface, stobbed into the surface, or stitched through the surface. Turf was used as a ridging material for many types

Illus. 34 The excavation of the turf at the ridge – note the rodent hole in the section (Historic Scotland)



Illus. 35 Turf layers overlying the ridge: N facing section (MM)

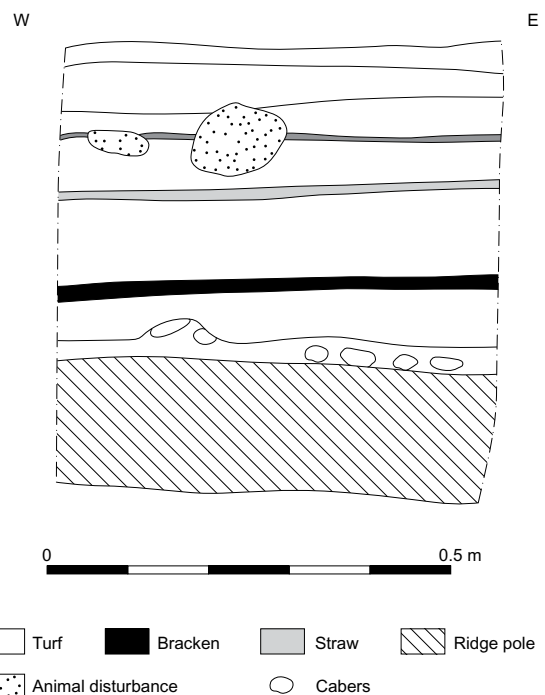

Illus. 33 Tippets or grips from the body of the roof (Historic Scotland)



of roofs including corrugated-iron, slate, stone and thatch. At Sunnybrae Cottage the 0.4 m of turf at the ridge was clearly the result of numerous repairs using turves from a source closer to the river than the turves of the main thatch.

The fact that the turves from the main part of the roof differed from the others at the ridge is of some interest. A large area of turf would have been required for the first thatching and the builders must have selected and obtained permission to strip a specific piece of heavily grazed pasture. The stripping associated with repairs at the ridge, which would have required much less turf and appear to have been taken from any available land closer to the cottage.

The basal layers of the thatch were heavily sooted indicating that rooms were probably open to the roof during this early phase. These could even be contemporary with the cuppills. The thatching technique used means that the bulk of what we see today, which has alternating layers of rye straw and turf, was part of the same thatching episode. A roof such as this probably had a useful life of no more than 20 years, probably less, but resurfacing and repair is unlikely to have involved the full stripping of the thatch back to the timbers. The turf in particular would have been very expensive to replace and it would seem far more likely that the original thatch would have been used as a substratum for later surface dressings. Most of the evidence for these later episodes was removed when the corrugated roof was added, but the occasional sprig of broom pushed up into the thatch from outside provides an indication of the materials used. Repeated resurfacing such as that suggested here can result in a significant build-up of thatch on roofs (e.g. Holden 1998) and in England, there are numerous examples of thatched buildings which retain a soot-blackened medieval substrata (Letts 1999). (Illus. 36a & 36b).

Illus. 36 Reconstruction showing how the building may have looked in Phase 1 – a turf building with thatched roof, turf ridge and central smoke hole

a) S elevation (BW)

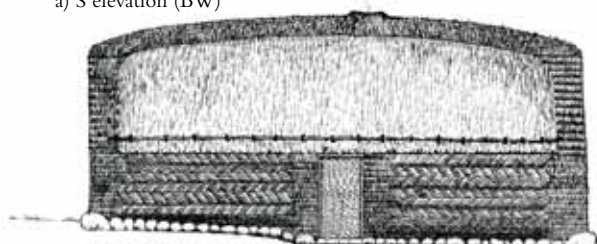

b) E elevation (BW)

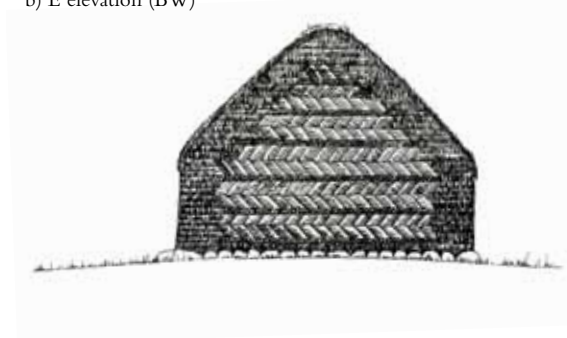

2.5 Internal layout

The physical evidence for the internal layout of the cottage in this early period is very scant. However, by combining the archaeological evidence from Sunnybrae Cottage, with historical sources and known examples and from other parts of Scotland, it is possible to suggest how the space was probably used. The cottage formed a simple rectangle in plan divided into three bays.

The archaeological evidence fails to confirm whether the house was a byre-dwelling or a two-roomed house but the earliest known occupant of Sunnybrae Cottage, Alexander Scott, was described as a farmer and distiller in 1841. As such he would have required a byre for his cow or cows and calf or calves. According to the census reports of the same year all the adjoining buildings were allocated to other families, there is therefore a strong indication that his house was a byre-dwelling. These were not unusual in the 19th century or earlier, even in towns, where many private houses had a cow to provide fresh milk. Had the home belonged to a tradesman or weaver, the E end of the house away from the kitchen would have been used as a workroom.

Illus. 37 Reconstruction – interior plan (BW)

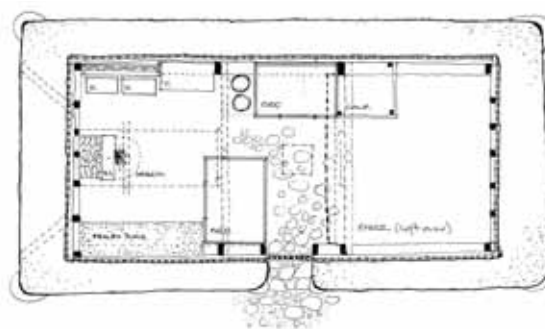

Illus. 38 Reconstruction – long and short sections showing the interior (BW)

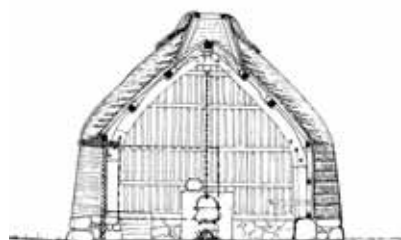
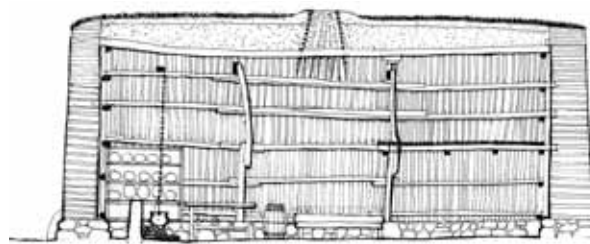

Illus. 39 Reconstruction – perspective
a) facing W



b) facing E (BW)

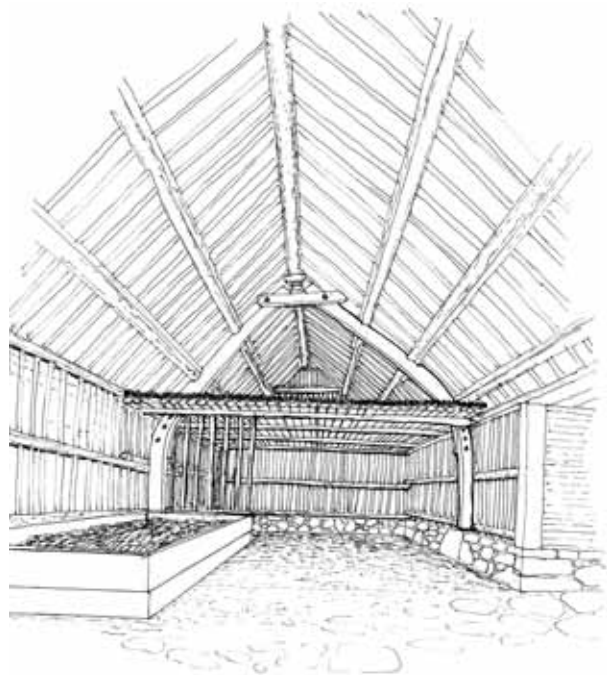

A byre-dwelling therefore seems likely and Illustrations 37 & 39 offer an interpretation of how the building might have looked if there had been a byre in the E half of the building. This would probably be lofted to allow a certain amount of bedding material and fodder for the cattle to be stored above them (Illus. 40). When there was a chimney, this provided an ideal space to put guests since they would be warm and comfortable but unable to move about freely during the night. This was important since Highland hospitality demanded that any person looking for shelter should be taken in if at all possible. Access to the loft was by a ladder that was removed once the guests were established in the loft. Even without a chimney the existence of cattle under a loft would result in a warm air current rising across the end closest to the hearth and this would prevent the penetration of smoke sufficiently to allow the loft to be slept in. At this stage there would be no ceilings other than a crude floor to the loft.

The entrance was probably in the same position as the one presently used which is situated halfway along the S elevation. This is a common location for a byre-dwelling where the cattle occupy about 40 per cent of the internal

space. 'Stake-and-rice' could have been used to construct the original doorway which, in the Highlands were often wattle panels, jambed into the doorway at night (Lucas 1956).

Since the doorways, often comprising little more than a wattle screen, were seldom draught proof the hearth was usually placed close to the door to reduce the distance the cold air travelled through the house to the fire. The draught can be further controlled by the introduction of a screen, known as a *hallan* or a cross wall, known as a *numva*'. A common solution is shown in Illus. 37–38. The layout shown is more typical of the 18th century but 19th-century genre paintings also show the *numva*' (Illus. 41) with the back stone to the hearth built against the wall.

It is unlikely that there were any recognisable windows at this stage other than small openings present in the gable. Light would enter the central area from the smoke hole and the front door. If one of the *numva*' solutions was adopted for the plan there may, however, have been a small window (without glass) behind the settle possibly on the door side of the cuppill.

Illus. 40 Byre loft – house cleared for a party or wedding (BW after David Allen 1744-1796)



Illus. 41 Approach of the Enemy – Painting with young woman sitting beside the hearth and old woman coming in the door and past a screen or *hallan* – Erskine-Nicol (26/53) 1865 © Dundee Museum & Art Gallery)



2.6 Hearth

No evidence for an early hearth was found at Sunnybrae Cottage, but central hearths associated with smoke-holes were reasonably common in most parts of Scotland before the 19th century, the chimney being a couple of feet along the ridge from a vertical line from the hearth. The housewife would benefit from the light entering the smoke-hole whilst heavy rain would fall clear of the fire. Another alternative would be to protect the turf walls with masonry and build the hearth closer to the end walls. Both systems are described by Hutcheson (1927):

'Where stones were available, in later times, a fireplace and chimney would be formed in the centre of the gables, but in all the early houses of this class, the fireplace marked but by a few chunky stones set in the floor, occupied the centre of the house, and to permit the smoke to escape a pyramid shaped chimney top was formed at the apex of the roof with branches plastered with clay, when it could be got, otherwise tied round and made close by straw ropes twisted round it.'

also

'a scheme of getting the fire removed from the centre was devised by erecting a big stone slab, if it could be got, one end sunk in the floor, or by building a bit of stonewall at about eighteen inches distant from the turf wall, the fire being in front of this stone or wall, secured immunity from setting fire to the turfs'.

18th-century descriptions of houses in this area are rare but an unpublished manuscript that relates to the area between Blair Atholl and Taymouth (Anon 1789) has the following description:

'The Highland hut is nothing but a few stones pulled loosely together and covered with broom, instead of straw, which, having laid until it is rotten, is itself covered with fresh broom and so on perpetually. The chimney, if it may be so called, which is only a small opening in the thatch is often in the middle of the building; and the fireplace is at one end, so that they live in a continual smoke; upon asking a Highlander why he did not make his chimney over the fireplace he returned for answer that, the rain would come in...'

In the above description, the hearth would be in the dark since windows would have been very small. A Wilkie painting of a 'Highland Wedding' used as a cover for a book about Blair Athol shows vertical slits in the gables of such houses which would be an effective way of lighting the hearth area. At Sunnybrae Cottage the evidence for this type of gable hearth would have been destroyed during the building of the later chimney breast, but the heavy deposit of tar on the roof timbers clearly indicates the likelihood of a smoke hole at this early date.

Illus. 42 A Cottars Saturday Night – David Allan 1789 © (National Galleries D/NG562)



2.7 Furnishings

Little is known about the furnishings of a small farmers or cottars house of the mid-18th century. With the central hearth arrangement, the logical place for the beds was at the opposite end of the living space. These could be timber box beds, stone enclosures for straw, or curtained beds as shown in the 1789 sketch for 'A Cottars Saturday night' (Illus. 42). Note the fabric canopy used to protect the bed from dust, soot etc falling from the underside of the cabers. Combinations of timber structure and curtain were also recorded by W Giekie in his tour (Illus. 43). This also shows the relationship between the living area and the stable. The use of fabric to protect the occupants from falling debris was commonplace and the use of fabric round a canopy chimney is intended to prevent people injuring their heads as they straighten up after tending the fire. The fabric touching the back of the head or neck warns the person to keep the head down.

Turf benches are mentioned in some reports, as are three legged stools, dressers, a table, kists for meal, clothing and household linen, box or closed beds, barrels for salt, fish (and meat?) and probably a plate rack. A metal chain and hook, known as a 'crook-and-links' was provided to support the cooking pot over the fire, or the pots may have been three legged types that sat within the embers of the fire.

Illus. 43 Two men drinking at a table in an inn – Walter Geikie © (National Galleries D4553)

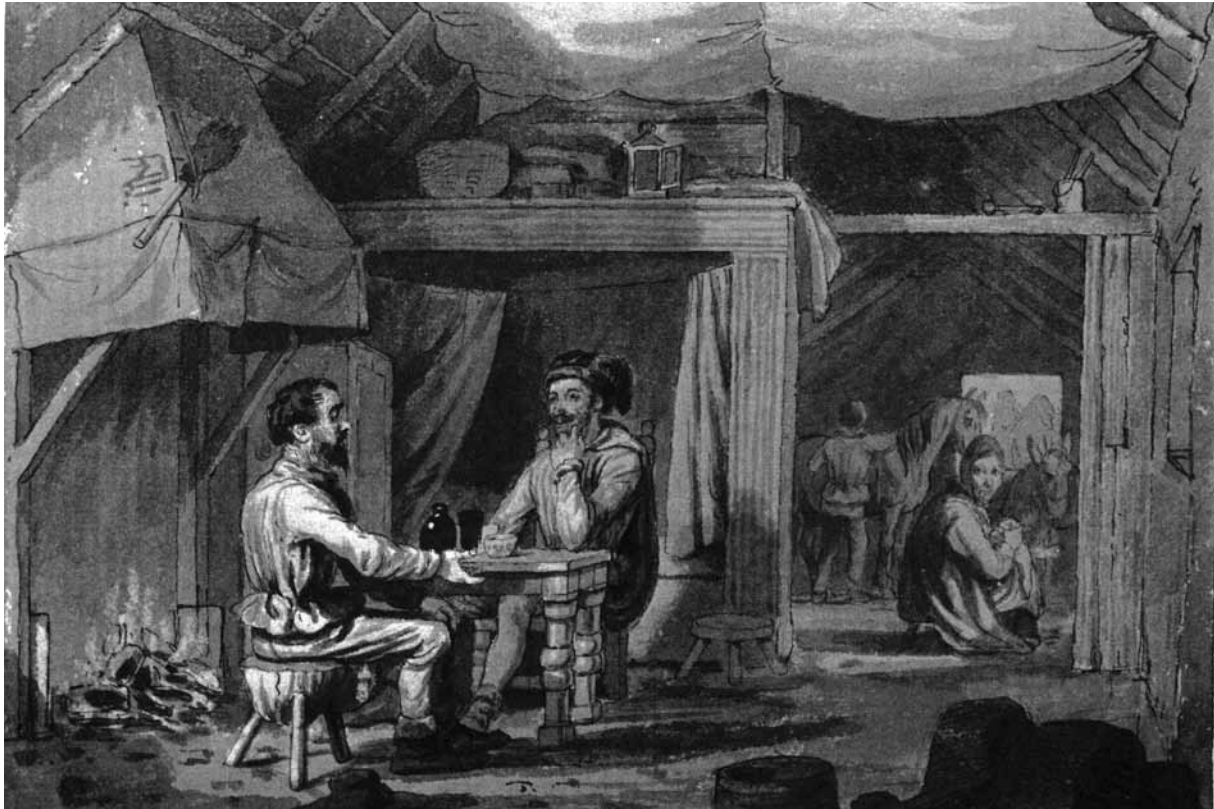

2.8 Discussion of Phase 1

The normal arrangement for the provision of accommodation was that all land and buildings belonged to an estate and the estate owner, in conjunction with his factor, determined the size of all dwelling houses and steadings in accordance with the size of the tenant's landholding.

In the early 18th century the basic unit of accommodation for a working class or lower middle class tenant was a single-roomed house: that is, the cooking, living and sleeping all took place in a single room, whether the household comprised a single person or a family of fifteen or more. There was no running water or toilet provision. The house was often erected by the tenant with the aid of the community using materials provided by the estate. Leases gave tenants the right to cut turf for building purposes, wood, thatching materials etc, but structural timbers were controlled by the factor and the birleymen. These houses were simple shells lacking windows, shutters, doors, partitions, ceilings

and chimneys. Small farmers, rural tradesmen, weavers, shoemakers and millers often had a two-roomed house, but the second room was normally connected with their occupation, i.e. byre in the case of a small farmer, a stable for a gamekeeper or a miller, a workshop for wright, or a loom shop for a weaver. These additional rooms were often provided with a loft used for storage, additional sleeping space, or both.

In the case of Sunnybrae Cottage a dwelling house with an internal link into the byre or stable is a strong possibility. This type of building is commonly referred to as a 'long house' in England and Wales, but this term was considered to be confusing in Ireland and Scotland where many houses form part of a long range of buildings that are not connected internally. In Europe, the local names normally translate as 'cattle housing' but was adopted as a term for all types of beef cattle rearing sheds by the Department of Agriculture and Fisheries in the early 20th century. A 'byre dwelling' is the preferred term today.

3 EARLY ‘IMPROVED’ HOUSE – PHASE 2

(early – mid-19th century)

3.0 Introduction

Apart from the material remains, evidence for the cottage and its inhabitants before the mid-19th century is slim but a plan of the Faskally estate from 1846 does show details of the cottage and its neighbours (Illus. 44).

Some of the 19th-century buildings can also be found in early photographs. Those taken for postcards by George Washington Wilson of Aberdeen and James Valentine of Dundee are particularly informative and capture the boom-town response to increased tourism following the visit of Queen Victoria in 1844. The smaller buildings in the photographs show, for example, a masonry frontage to the thoroughfares and timber slab construction to the garden ground at the rear. Later the slab construction is replaced with either masonry or brickwork and the thatched roofs are covered over with corrugated iron.

It is within this context that this second Phase of building at Sunnybrae Cottage takes place. Little is known about the occupants of cottage (see Table 2) but their tenancy sees the replacement of the earlier walls with clay-mortared stone masonry (Illus. 45). There is no evidence to suggest that the roof was dramatically altered but the level of the ridge may have been changed to suit the newly constructed masonry gables. The 2nd edition OS Maps (1900) also suggests that there must have been a shed or byre, against the W gable of the cottage because it appears longer than on the 1st edition (1861) (Illus. 46).

Illus. 44 Faskally Estate Map of 1846 P McLagan



3.1 Timber floors

Excavations within the building revealed no evidence for an early floor surface so it seems likely that this was raked out to retain headroom on the insertion of the current suspended timber floors. The evidence suggests that the boards in the E room are considerably older than those elsewhere. The majority are butt jointed and not of standard width (14-17 cm wide) (Illus. 47). The joists comprise timbers that were sawn on one side and roughly hewn on the other. This is normal in early timberwork where the timber was supplied in square baulks from the forest and sawn later by the carpenters. The joists sit directly on rounded boulders set into the subsoil.

Table 2 – The owners and occupants between 1841 and 1857

Date	Owner	Occupier	Comments
1841	Archibald Butter of Pitlochry	The house is occupied by Alexander Scott , his wife and daughter Margaret Scott , William Dick , Margaret Campbell , Ann Dewar and John Campbell .	In 1841, the earliest census to work by households shows the house (Sunnybrae Cottage) to be occupied by Alexander Scott, farmer and distiller, age 35; his wife age 30; and daughter Margaret age 2: William Dick, agricultural labourer age 18: Margaret Campbell, female servant age 20: Ann Dewar age 10 and John Campbell age 14.
1857	Archibald Butter of Pitlochry	In the valuation rolls of 1857 the tenant is thought to have been either Christine Duff or Isabell Campbell .	

Illus. 45

a) Longitudinal section looking towards N internal wall (HS)

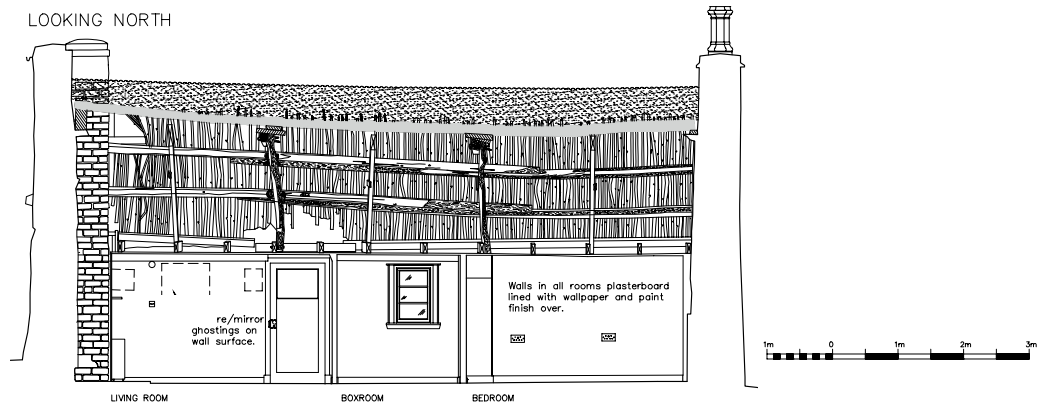

b) Longitudinal section looking towards S internal wall (HS)

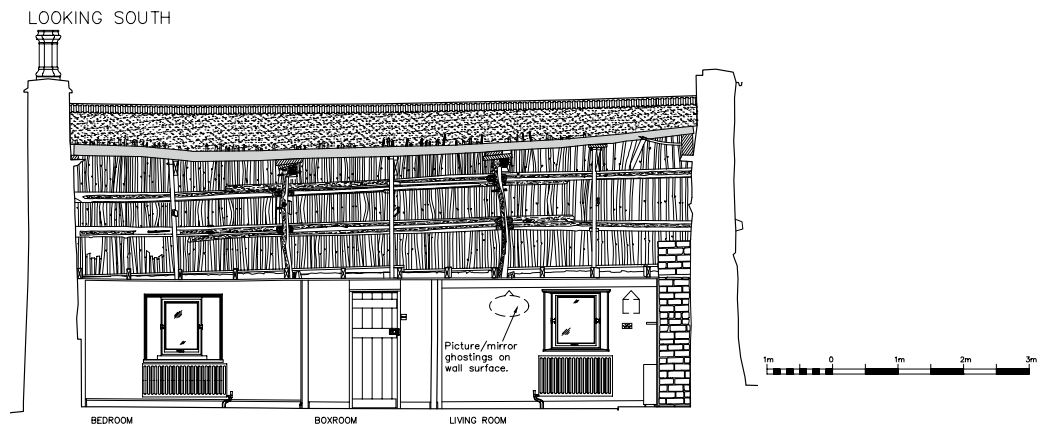

c) Cross sections and elevation of W wall (HS)

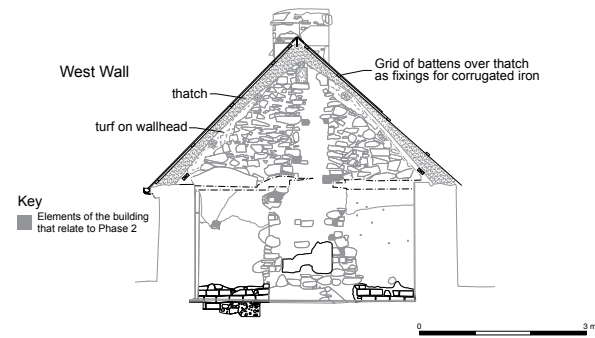

Illus. 46 The Ordnance Survey maps for 1862 and 1900



a) OS map of 1862

d) Cross sections and elevation of E Wall (HS)

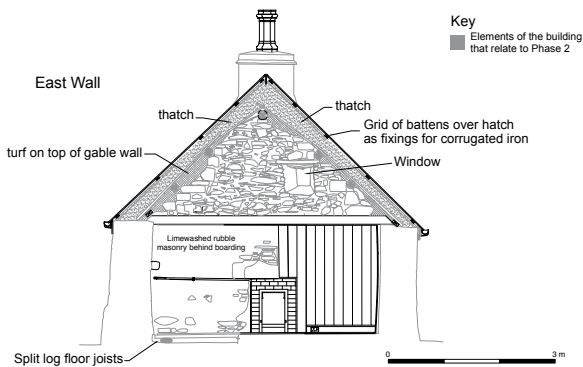

b) OS map of 1900

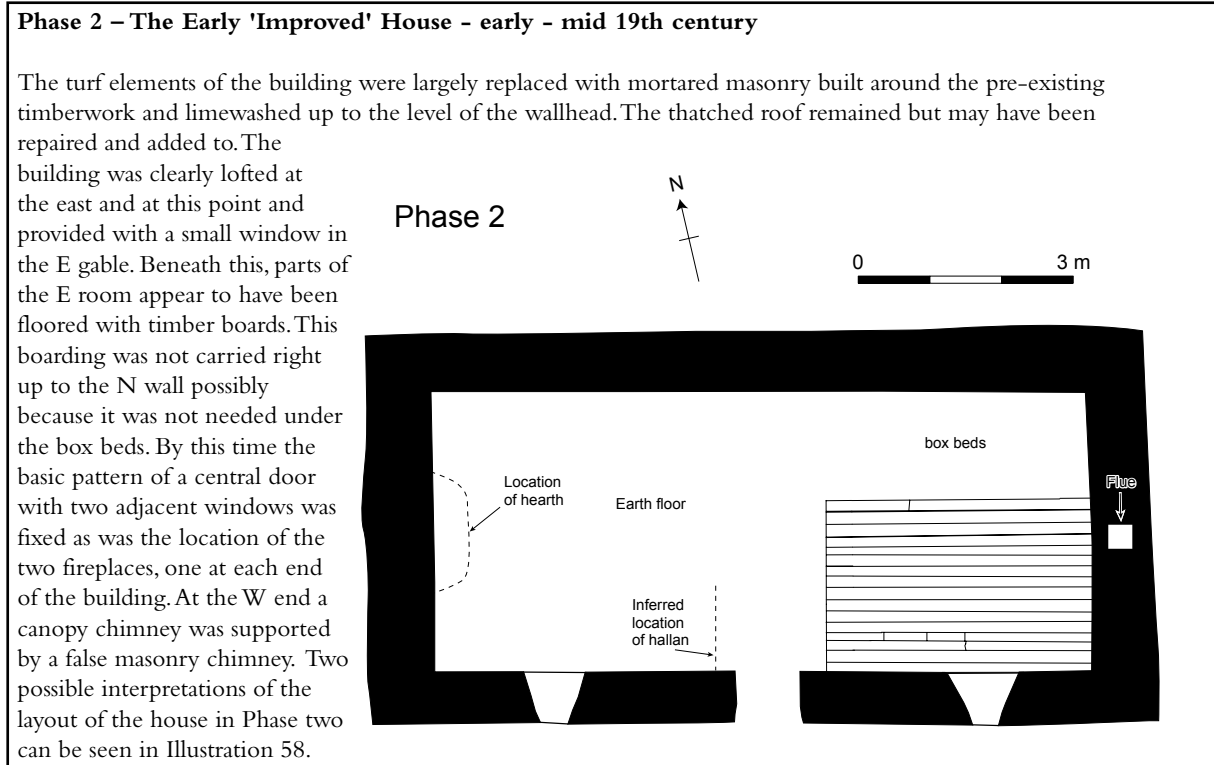
Illus. 47 Ground plan of the Early 'Improved' House (HS)

Interestingly the early boards did not run right up to the N wall leaving an un-floored area of 1.5 m x 2.6 m. This is thought to have been the site of two box beds up to which the first boards were taken. This gap was patched later with tongue and groove boards on half-rounded joists.

The evidence suggests that in Phase 2 the bedroom was provided with a suspended timber floor that was built up to, and around, the box beds against the N wall. It would seem likely that the kitchen/living room area retained its earthen floor until somewhat later.

3.2 Masonry walls

Above the stone footings, the walls of the original turf building were removed and replaced with clay-mortared random rubble masonry. At the rear of the house the walls were, and still are, battered, presumably to resist the slide of the building down the gentle slope to the N (Illus. 48). In most places the walls were up to 0.7 m wide and were built up to the wallhead height on the N and S walls. The gables were also constructed at this time but it is clear from the surviving walls that were not taken up to their full current height. It therefore seems very likely

Illus. 48 A section of the battered N wall (Historic Scotland)

that the upper courses of the gables were made of turf where there was a need for the walls to accommodate the irregular lines of the roof timbers and thatch. Turf at this point in the wall may also have facilitated the pegging of rope fixings for the thatch into the wall. This seems to have been a common solution and many earlier roofs

had turf tops to the gables in horizontal courses (Illus. 49a-f) Walker 1997. At either end of the building three crude, irregularly spaced, corbels project from the gable wall. Although there are several possible explanations for these the most likely one is that they were for anchoring the thatch during this period.

Illus. 49. Suggested construction sequence for Phase 1

a) The turf walls are removed in sections with roof supported on the cuppills (BW)

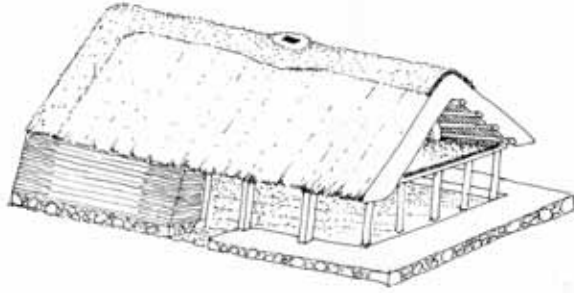

b) Sections of turf are replaced by stone masonry (BW)



c) Gable walls are of stone, canopy chimney installed and the gable walls made to full height with layers of turf (BW)



d) Central smoke hole blocked, gables and ridge finished with turf (BW)



e) The thatch may have been carried over an outhouse against the W wall

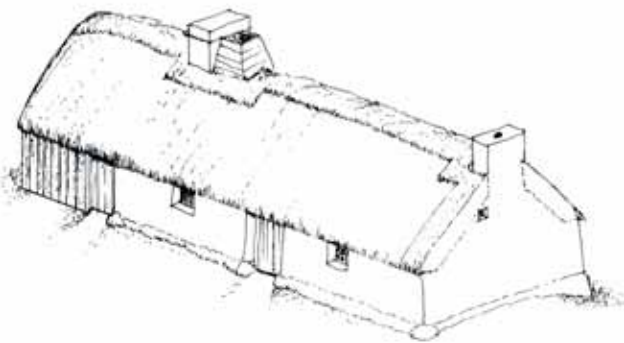

f) The completed building and outhouse from the rear showing the possible use of 'backs' (BW)

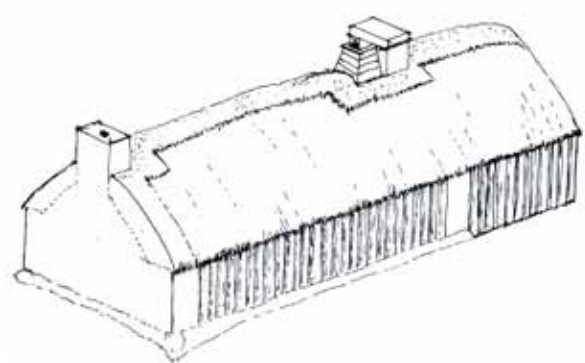

Replacing turf walls with masonry

This was a simple operation since the roof was fully supported on the cuppill structure that carried the weight to the foundation course. This was necessary since turf walls had a tendency to shrink vertically as material dried out and consolidated. The shrinkage could be made up with new material inserted

between the lowered wall end and the base of the roof. House owners and builders were aware of this facility and utilised this aspect of the design to periodically remove sections of the wall, and replace these in masonry, without disturbing the structural integrity of the roof. The practice of beam filling was possibly a continuation of the practice of stopping up the gap at the eaves.

Turf top courses to masonry walls

Many houses in crofting districts, where thatch remained the predominant roof covering until the recent past, had several courses of turf along the eaves and/or skews of the house. At the eaves, the band of turf was used to provide a surface that would accept pegs used to restrain the ropes of the thatch. The main advantage was that it allowed the pegs to be moved to tighten the ropes once they had stretched. This form of construction was eventually superseded by attaching free hanging stones or other weights to the ropes thereby providing a continual even strain on the ropes.

At the skews the turf layer formed the vulnerable junction between the wallhead of the gable and the thatch. The turf used for this purpose was normally taken from the surface of a peat bog and therefore contained natural 'oils', which once dried out tended to make the skew waterproof. Where waterproof turf was unavailable the gable wallhead was formed as a series of crowsteps which gave some protection from water penetration whilst providing a series of platforms to support the turf which formed the finished screws and covered the joint between masonry and thatch.

Illus. 50 Turf is commonly used at the gable head where it provides a good seal between wall and thatch. It is applied in horizontal courses of divet and pegged through the courses below (BW).

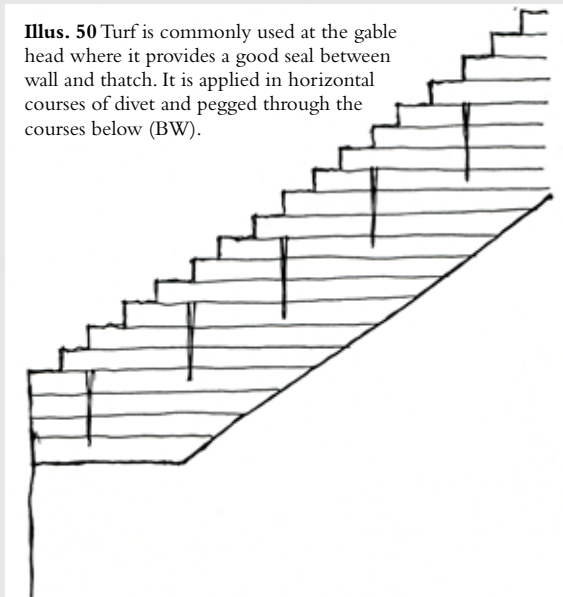

The skews at a small Celtic cuppilled house at Drumdewan, Dull, Perthshire were recorded as the thatch under the corrugated-iron roof was dismantled circa 1975 (Walker 1979c) (Illus. 50). The pegs were placed in such a way that they could be covered by the succeeding course and the stepped surface was subsequently covered by the skews that lapped over the joint between skew and thatch.

Mortared stone walls

Field Boulders

This term is applied to any type of rock removed from the surface of the ground in the course of clearing the land or subsequent ploughing. Attempts would be made to find or prepare larger rocks to form quoins at the doorway and corners of the building whilst smaller stones with a roughly squared corner would be used at the windows. Other stones were, if possible, used as found although the problem of transport over rough terrain may have encouraged the builders to break up the rock before transporting it to site. This could account for the apparent use of quarry redd.

Quarry Redd

Quarry redd is any broken stone, from a quarry, not considered suitable as a proper building stone. It is usually used for hardcore and packing purposes and many tenants agreements allow quarry redd to be removed from estate quarries at times of inactivity provided it is for use on the tenants holding.

Mortar

At the time of the building of Sunnybrae Cottage, mortar was by definition an earth mix, occasionally also containing straw.

Lime Mortar

Lime was seldom used as a mortar in Scotland. Dunbar (1966) reckons less than 15% of masonry buildings in Scotland utilize lime as a mortar and these are mainly buildings built by incomers such as English and French monks setting up new monastic settlements. English based railway and other utility companies and so on. It is extremely unusual to find lime mortar in vernacular buildings unless the wall is of a very late date. Possibly during the materials shortage after World War II when local builders still had old supplies of lime putty for plastering and the works that were proceeding officially were using the available supplies of cement for mortar and gypsum plaster for the finishes.

All walls below the ceiling level, inside and out, had been given numerous coats of thick limewash. In some places on the inside, notably around the hearth, layers of linen and newspaper had been added to provide a smoother surface. One fragment of *The Scotsman* newspaper from the area to the N of the W hearth has provided a date of 1861 (Illus. 51). A second fragment from over the NE cuppill blade records the launch of the Agamemnon warship that is known to have occurred in 1852. These clearly indicate that the internal finish was limewashed masonry at least up until the 1860s.

Illus. 51 A fragment of *The Scotsman* newspaper from 1861

The E, S and W walls appear to be of one build, all with rounded boulders and multiple smooth lime wash finishes. The inner face of the N wall is, however, very different. It is built with split boulders, some part limewashed, lime mortar with timber battens set into it. There is no limewash finish and it is very clear that this has been clawed back and consolidated/part rebuilt with lime mortar. The most obvious explanation for this is that the Phase 2 masonry wall failed and that it was rebuilt using the same masonry during Phase 3. There is, however, an outside possibility that the rear wall was formed of wooden ‘backs’ and that the N wall was only later replaced with stone and mortar (see Illus. 58 which shows two possibilities).

Illus. 52 Close up of the false chimney on the W gable (Historic Scotland)

At the E end of the building the gable wall incorporates a hearth, flue and chimney. From the outside the W end appears to be an exact mirror image but the chimney is, in fact, a purely decorative feature with no matching hearth and flue (Illus. 52). The hearth at this end of the building evidently projected into the room and was vented via a canopy chimney supported against the gable wall (see section 3.6 below).

On the gable walls the limewash finish was only carried up to the height of the N and S wallheads and may suggest the presence of some sort of covering at ceiling height. Just to the S of the canopy-chimney the limewash seems to have been painted up against some pre-existing structure above the ceiling level. This may be evidence for a press or something similar against this wall.

The walls themselves are relatively featureless although there is a small recess in the S wall beneath one of the present windows. Numerous small dooks can be seen, particularly in the W and S walls of the W room. These, it is assumed, were fixings for shelves, racks, pictures or pegs for hanging things.

3.3 Thatched roof

The ridge tree is supported in either gable by a stone corbel. These corbels are approximately level with each other but at the W end the pole sits on a section of ash timber approximately 30 cm long. Exactly why this has been inserted is unclear but it seems likely that the ridge tree used was bowed or had sagged and did not sit firmly on the W corbel.

That the house was still thatched at this time is indicated by three things:

- The masonry chimneys were constructed with ‘thack stanes’ (thatch stones) at their base. These were designed to carry water runoff from the chimneys onto the surface of the thatch
- At the base of the sawn boards of the wooden chimney is clay seal that would also have carried water runoff onto the surface of the thatch
- The gables during this phase were approximately 40–45 cm lower than the later ones associated with the corrugated-iron roof. The thatch in the earlier phase would typically have been carried over the skews.

AV-shaped timber gutter would typically be formed over the doorway to deflect the drips from the thatch. Often the brackets supporting this gutter were adjustable to allow the gutter to be moved according to the thickness of the thatch. The inside faces of the gutter were often tarred to provide greater protection to the timber. The brackets sometimes project from the masonry of the wall and are sometimes cranked to allow them to be fixed to the timbers supporting the thatch.

3.4 The extension against the W wall

The 2nd edition OS Maps (Illus. 46) shows the building to have been longer than at present. In an attempt to discover the nature of this extension a trench spanning the full width of the building was excavated 2 m to the W of the main building. This exposed a series of features very close to the surface including a drain and soakaway and the foundations for a small coal store (1.5 m x 1 m). These were all associated with late 19th- and 20th-century finds and so added little to our understanding of any earlier building on that side of the cottage.

The absence of masonry foundations to the W of the building suggest that the increased length was probably

due to the presence of a timber shed, possibly a byre against the W gable. This was, and still is, a popular way of extending properties during the period and could explain the presence of three projecting stones in both the E and W gables (see Illus. 57b). Although these are not symmetrical they could have been used to support off-centre roof timbers of an extension. Commonly, 19th-century sheds could have been planked as shown in the photographs from the Blair Atholl Archive (see Illus. 54), or of squared backs as shown in photographs of Pitlochry (see Illus. 55). This technique recorded on early photographs of the Blair Atholl Estate comprise a standard partition clad with butt-jointed vertical boards with internal or external cover straps to the joints.

Timber walling

"Backs"

Photographs taken towards the end of the 19th century show a considerable number of timber walled dwelling houses and outbuildings utilising the "backs" left after squaring logs in a sawmill (Illus. 53).

Illus. 53 Log squared to produce a balk and backs (BW)

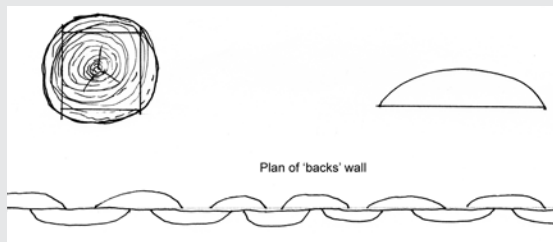

In the simplest application of this technique the outer "backs" are evenly spaced along the gable and the spaces between them are filled by the sawn face of the inner backs to give continuous protection (Illus. 54).

Illus. 54 Timber extension (Atholl estate archives)



A more elaborate form of the same technique is shown in another George Washington Wilson photograph of Pitlochry (Illus. 55) where the backs are cut to have three square sides, allowing them to be butt-jointed on both the external and internal faces whilst still lapping the joint (Illus. 56).

Illus. 55 Timber extensions using 'backs' in Pitlochry (GWW 1101)



Illus. 56 Squared 'backs' wall (BW)

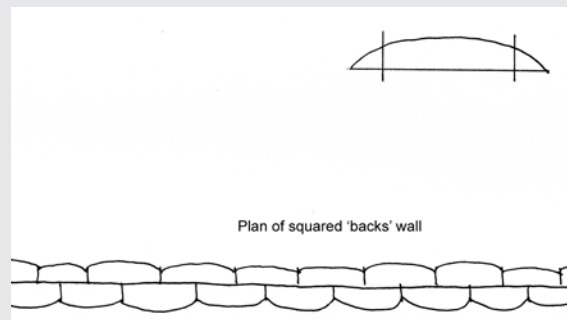

Timber "backs" used in this way would provide a reasonably substantial wall for a few years but they would not last very long since they are essentially sapwood and subject to insect infestation and rot.

Standard walls and vertical boarding

These could be cleft boards as recorded by Brewster (1830) or sawn boards as produced in considerable quantities later in the 19th century.

Illus. 57 Reconstruction showing how the building may have looked in Phase 2 – a thatched stone building with a gable hearth at the E end and a canopy chimney at the W end

a) S elevation

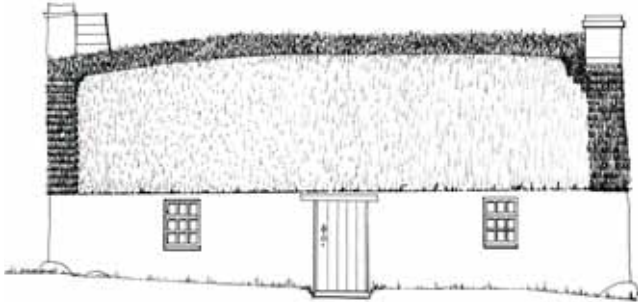

b) W elevation (BW)

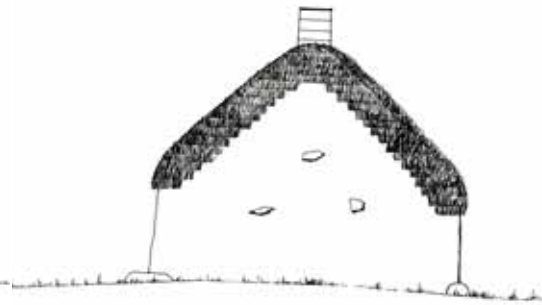

3.5 Internal layout

The locations of the door and windows at this point were probably the same as at present. The splayed window embrasures revealed beneath the wooden panelling still have limewashed cheeks that are indistinguishable from, and therefore broadly contemporary with, the rest of the S wall. Just to the W of the entrance a vertical lime mortar scar represents the remains of, a screen or *hallan* designed to protect the kitchen area from draughts. This would have diverted draughts in the kitchen area away from the settle. There is currently a blocked window high in the E gable indicating that the E part of the loft space was floored and probably used for storage or occasional sleeping accommodation (Walker 1988a & b). The W end of the building is likely to have stayed open to the roof timbers. (Illus. 64a, 64b, 65a, 65b, 65c). To the S of the canopy chimney an area of limewashed wall appears to represent the inner face of a press that once stood against the W gable.

Illus. 59 Phase 2 Reconstruction elevations & sections of the interior

a) N elevation showing canopy chimney and box beds

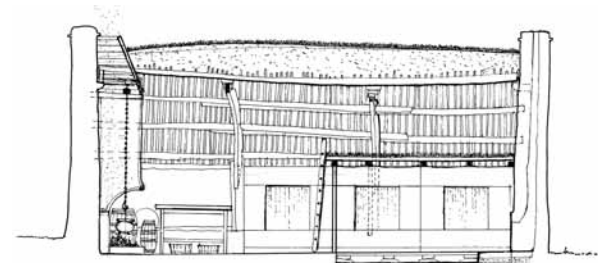

b) W elevation showing the canopy chimney and press

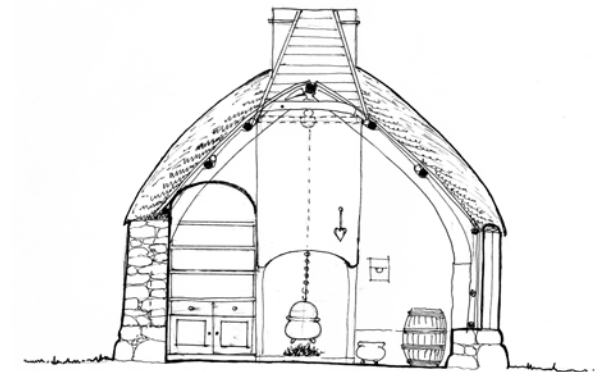

c) E elevation showing the loft (BW)

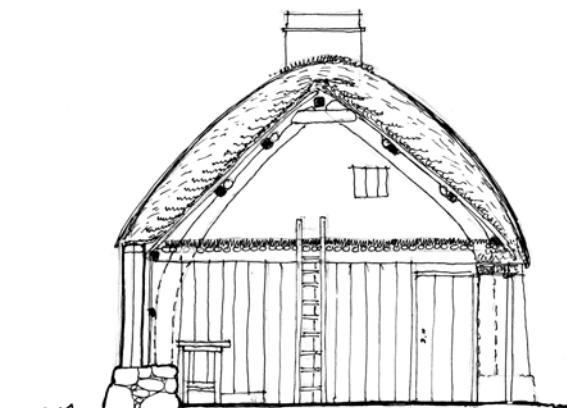

Illus. 58 Plan showing two possible interpretations of the Phase 2 House

a) with a masonry wall and

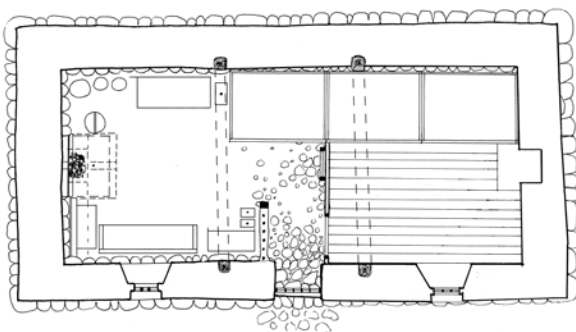

b) with a wall formed from timber 'backs' (BW)

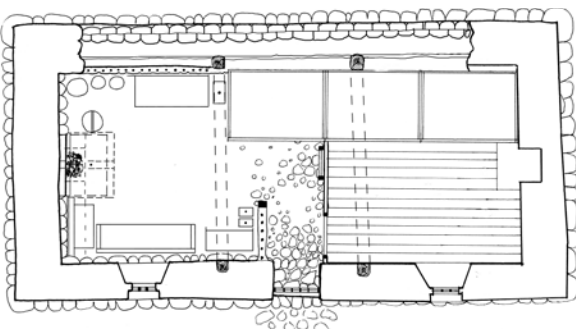

3.6 Canopy chimney

High in the roof above the western fireplace is a framework of timbers that are variously hewn, sawn, pegged and nailed. These are the only remains of a canopy chimney (Illus. 66 & 67). The main supporting timbers are fixed to the purlins with small diameter cross-pieces pushed through drilled holes in their upper surface. The uppermost surviving timbers comprise sawn boards fixed with blacksmith-made nails. These timbers would originally have extended above the surface of the thatch to form the chimney. A spread of clay at the base of these would have sealed it and shed water onto the surface of the thatch. An example of a false stone chimney with canopy counterpart can be seen (Illus. 63), the timber chimney resting directly against the stone-built false chimney in the left of the photo.

Within the W room no evidence survives for the structure of the canopy chimney, although limewash on either side of the hearth had clearly been smeared up to a structure over the hearth. This at least provides us with a width for the canopy. If the canopy was originally tied into the W wall the evidence for this has been removed by the later brick chimney. There is no surviving evidence for any of the materials used its construction although a large fragment of linen cloth was found amongst the rubble packed beneath the 20th-century concrete hearth. The absence of any suitable timber socket holes in the W wall, however, probably indicates that the lower part of the canopy was supported on the cheeks or backstone of the hearth.

Illus. 60 Timbers of the canopy chimney taken through the excavated section of the thatched roof (Historic Scotland)



Illus. 61 Timbers of the canopy chimney showing the timberwork in the roof space – explanatory drawing (ME/MM)

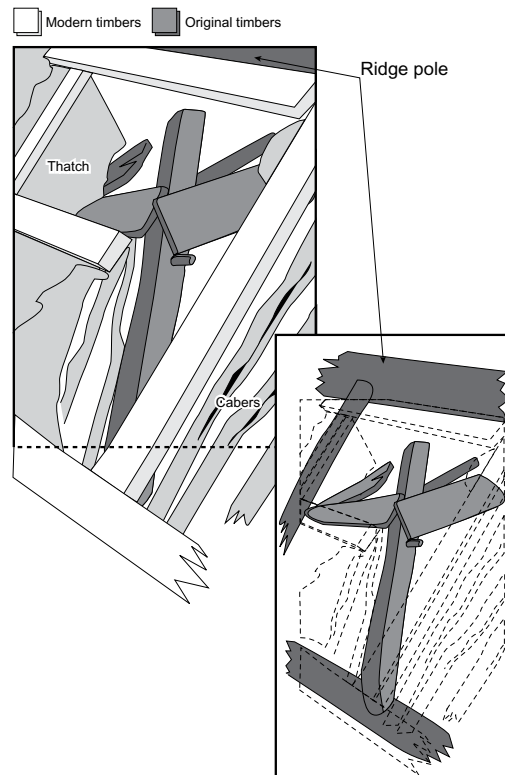

Illus. 62 A cottage in Moulin with a canopy chimney supported against a false masonry stack – this is very similar in form to Sunnybrae Cottage (BW from a GWW postcard)



Illus. 63 Sketches of a 19th-century canopy chimney by Walter Geikie (D/4427/889 © National Galleries of Scotland).

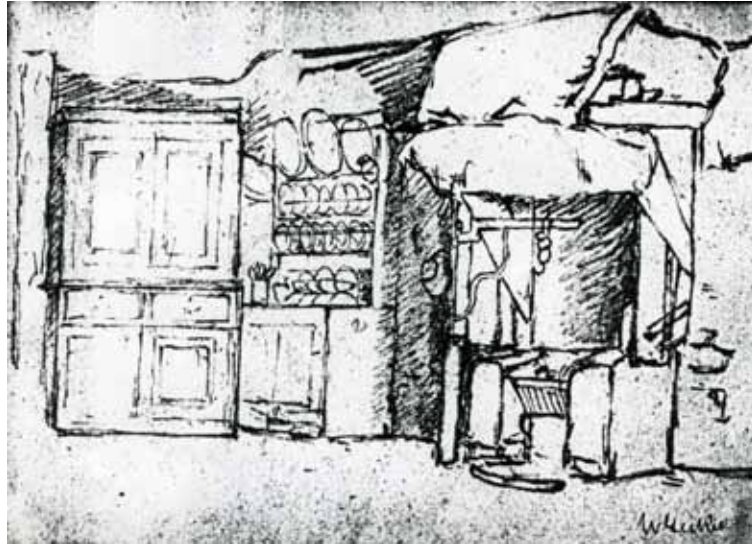

Canopy chimneys

Generally speaking, the smaller the cross-sectional area of a flue from a fireplace the stronger the draught within the flue. Gable flues, that is those built within the thickness of a gable tended to be nine inches square or nine inches diameter if lined in ceramic. This gave a good compromise between the draught generated and any tendency to produce downdraught but increased the risk of sparks and chimney fires when the chimney was sooty. Chimney fires were an acceptable risk when the roof was clad with slate tile or metal, but were extremely dangerous when the roof was thatched (Walker 1986). (Illus. 63 of Geikie sketches of canopy chimneys).

The normal situation in many parts of the country including Perthshire was: to use a gable flue in the best room, since that fire was rarely lit and therefore not susceptible to heavy sooting; and a canopy chimney in the kitchen where the fire was lit every day and in some instances kept going all the time. This is exactly the situation at Sunnybrae Cottage.

Illus. 64 Phase 2 Reconstructions
a) facing W

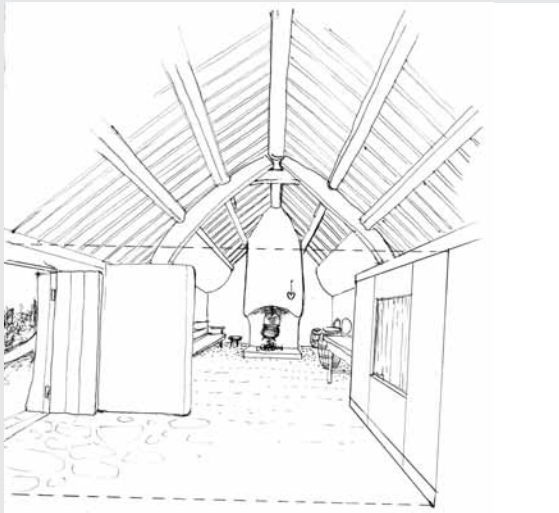

Some canopy chimneys were called 'hanging chimneys' not because they hung from the roof or walls, but because they were used to hang meats and fish to cure. The term 'hanging' was a late term coined by a journalist in Aberdeen in 1905 who failed to realise the difference between a simple canopy chimney and a hanging chimney. Hanging chimneys date from the 17th century and were often built as features in the garden grounds of mansion houses to allow distinctive fuels to be used produce specific flavours in the meat and fish. As the taste for these types of food moved down the social scene, canopy chimneys were adapted to the purpose. The meat was being smoked, wrapped in brown paper to prevent it from being soot-covered. Photographs showing paper-covered hams hanging in farmhouse kitchens are reasonably common. – Walker 1978d, 1979a, 1979e, 1979f, 1980 b&c, 1981a and 2008c.

b) facing E (BW)



Illus. 65 Sketches of a 19th-century interior by Walter Geikie (D/4427/889 © National Galleries of Scotland).

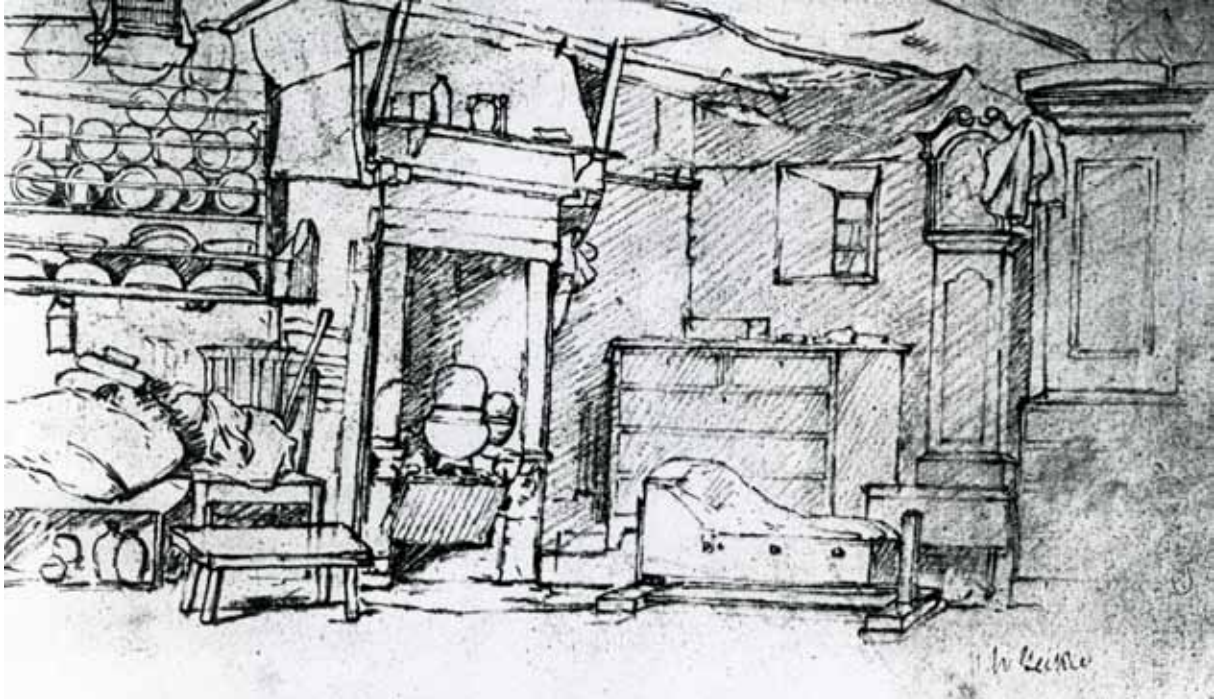

3.7 Furnishings

Much more is known about the furnishings of houses in the first half of the 19th century. Farmers had higher expectations and were more aware of social standing. Their houses may have remained basic structures, since they belonged to the estate, but furnishings were of a higher standard, probably purchased in years of plenty. The kitchen would have been furnished with bench, table, dresser, and closet beds (all of a higher standard of workmanship than was found in the 18th century) with a collection of kists, tubs, barrels, and pots. The tenant would have a canopy chimney, in some cases fitted out for the smoking of meat or fish (hanging chimney) and utensils such as a bannock rack or a griddle and bannock spade. These varied considerably in quality as can be seen from the interiors illustrated by Walter Geikie during his tour of 1828. Geikie shows many better class farmhouses with fabric ceilings or roughly boarded ceilings, but Sunnybrae Cottage is more likely to have had fabric ‘coombs’ over the bench and table/dresser area (see Illus. 43). (Illus. 65)

The table was commonly folded or/and moved to the wall opposite the bench in the evening but occupied the area in front of the fire during the day. Geikie, who was travelling and sketching outdoors during the day, always shows the table to the side and in the case of folding tables, folded away. Carse and Wilkie who tended to paint in the farmhouse during the day usually show the table in front of the fire.

A ladder provided access to the loft over the ‘room’ and the room was provided with closet beds and better class chairs, kists etc. There is less information available about the ‘room’ furnishings since most of the readers and artists were more concerned with the ‘working’ part of the house.

3.8 Discussion of Phase 2

Phase 2 sees the remodelling of the house whilst still accepting the basic structure. During this phase the turf walls were gradually replaced with clay mortared masonry. The byre, if one ever existed within the building, was removed from the house and the milk cow and any garrons (Highland ponies) housed in a byre and stable elsewhere, possibly against the W gable.

The space formally occupied by the byre/stable or a room at the E end, was partly raked back to allow the insertion of a random width boarded floor, set on joists, supported on randomly placed boulders. The beds would have been situated along the N wall and a window inserted into the S wall. The new fireplace in this room was built with a gable flue and the gable provided with a small window into the loft space above the room. A third bed appears to have extended out of the room into the kitchen. This assumption is based on a different pattern of tongued and grooved flooring inserted into this area at a later date. A ladder between this kitchen bed and the door would typically have provided access to the loft. Evidence for a *hallan* in the

kitchen at this stage is provided by a lime mortar scar in the masonry. The fireplace was now definitely against the W gable and was provided with a canopy chimney. The kitchen retained its earth floor and the masonry walls were limewashed internally. A small window was provided in the S wall of the kitchen.

These changes are likely to have occurred circa 1840 and are all in accordance to what might be expected of a lower middle class house.

In laying the timber floors in the room the projecting stones of the original base course are likely to have been removed and the walls made good in the S E corner. This period is likely to be furnished with the strange mixture of quality furnishings and vernacular items shown in Walter Giekie's drawings of 1828 (Illus. 65). The improvised nature of the ceilings in these drawings compares, badly with the quality of the furnishings. This can be explained by the fact that the house belonged to the estate and there was no guarantee that the estate would make any allowance for 'developments' at the end of a tenancy hence the flimsy nature of the ceilings and partitions. Furniture, on the other hand belonged to the tenant and could be removed by him at the end of the tenancy.

The lower strata of the thatch from the earlier periods was retained and a surface dressing of broom appears to have been added.

The early maps show what appear to be a temporary structure against the W gable. This could have been planked as shown in the photographs located in the Blair Atholl Archive (see Illus. 54), or of squared backs as shown in Washington-Wilson's photographs of Pitlochry (Illus. 55).

From the 1840s until the 1880s, the house probably diminished in status from a small farmhouse to a landless cottage. By the end of this phase the kitchen could still have the earth floor, limewashed walls and lack a ceiling but the beds would be reorganised in the centre of the house: one facing the kitchen, the others in the room. Behind the beds was probably a small pantry, entered from the kitchen, with a window (smaller than that shown) with a zinc mesh screen rather than glass.

The Phase 2 house is broadly, rather than accurately, symmetrical and is unlikely to have seen any input from an architect. This tends to confirm the suspicion that the house layout predates the late 18th century when the improving landlords were generally adopting classical principles for new buildings. In buildings erected on such lines the facades were deliberately designed to be symmetrical rather than simply expressing the requirements of the rooms enclosed.

4 LATER ‘IMPROVED’ HOUSE – PHASE 3

(c. 1890s)

4.0 Introduction

Sunnybrae Cottage only took the name of Sunnyside or Sunnybrae Cottage in the late 19th century when the property and adjacent land to the W was bought by Arthur Anderson, the Inspector General of Hospitals in HM Service. It was Mr Anderson who constructed a large villa on the site which he named Sunnybrae. The name ‘Sunnybrae Cottage’ was therefore attached to the present building because of its association with Mr Anderson’s new residence. Much of the evidence of the 19th-century ownership (summarised in Table 3) derives from census data but since the enumerators did

not always visit the houses in the same order it is often difficult to know which buildings were which. However, the Valuation Rolls, which were undertaken every year for the purpose of rating, do enable us to identify the owners and tenants of the various buildings. The value placed on Sunnybrae Cottage remained at £4 valuation from 1841 until the 1930s.

This phase sees some major refurbishments involving the structure of the building and complete modernisation of the internal space. Externally, the building attains its present form with the raising of the skewes and covering of the thatch with corrugated iron (Illus. 66a-e).

Table 3 – The owners and occupants of Sunnybrae Cottage 1871-1934

Date	Owner	Occupier	Comments
1871	Arthur Anderson and his wife Juliana M Anderson (nee Renny) built Sunnybrae House.	In 1871 the occupants of “Sunnybrae Cottage” appears to be Alexander Strang , his wife Helen Strang , daughter Margaret Strang , and a farm servant Archibald Campbell .	The census shows Alexander Strang (farmer and carrier), age 59 years; his wife Helen Strang, age 59; daughter Margaret Strang, age 22; and a farm servant Archibald Campbell, age 16 occupying a house with two rooms. Arthur Anderson MD was Inspector General of Hospitals in HM Service, CB (Companion of the Bath). He died in 1896. Both the ground to build Sunnybrae House (1 acre 14 poles) and the existing cottage, later to be known as Sunnybrae Cottage were feud from Archibald Buttar of Faskally Estate by Arthur Anderson .
1881	Arthur Anderson	In the 1881 valuation rolls J Ward , was the gardener in “Sunnybrae Cottage”.	
1891-1893/4	Arthur Anderson	Peter Ward takes over the tenancy from his father.	The 1881 census has Peter Ward, head, age 18; Ann, mother, age 43; Mary, sister, age 14 (millworker); Agnes, sister, age 11; John, brother, age 10; and James, brother, age 7.
1896	Arthur Anderson	Donald Cameron , his wife Ann Cameron (nee Macdonald) and daughter Miss Annie Cameron were tenants.	Donald Cameron is described as a retired gardener and Miss Annie Cameron as a housekeeper, probably both at Sunnybrae (House). The Cameron family were confirmed as joint liferenters by Authur Anderson’s trustees in 1896.
1896 – 1934/5	David Murie Stewart is given as the owner of Sunnybrae House from 1897 in the Valuation Roll.	Donald Cameron , his wife Ann Cameron and daughter Annie Cameron continue in occupation.	Miss Annie Cameron’s father Donald died in 1900. Although he was survived by his wife, it was Miss Annie Cameron who then was designated propriatrix. At that stage Annie gave the cottage name as “Sunnyside” but as early as 1901 it is referred to as by as “Sunnybrae Cottage”. In the 1901 census for the occupants are given as: Ann Cameron, head, widow, age 77 last birthday, born Little Dunkeld, speaks: English and Gaelic, and Annie Cameron, former housekeeper, age 43 years last birthday, born: Little Dunkeld, speaks English and Gaelic.

Illus. 66 Phase 3 Surveyed sections and elevations (HS)

a) N wall

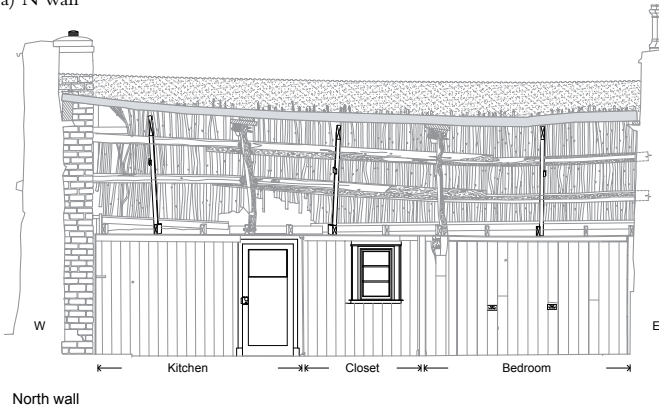

b) S wall

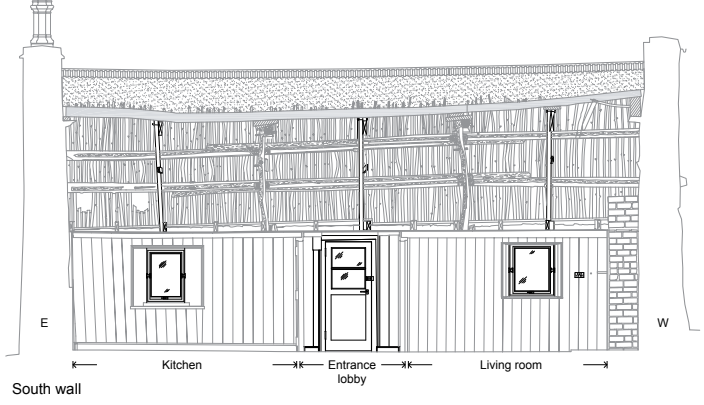

Key

■ Elements of the building that relate to Phase 3

0 3 m

c) W wall, with lining

West Wall

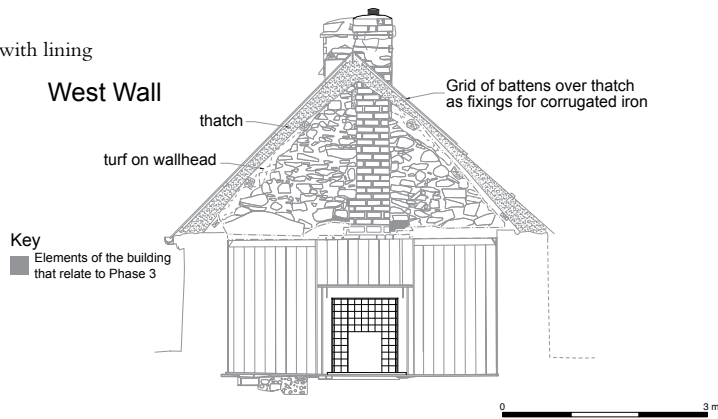

0 3 m

d) W wall without lining

West Wall

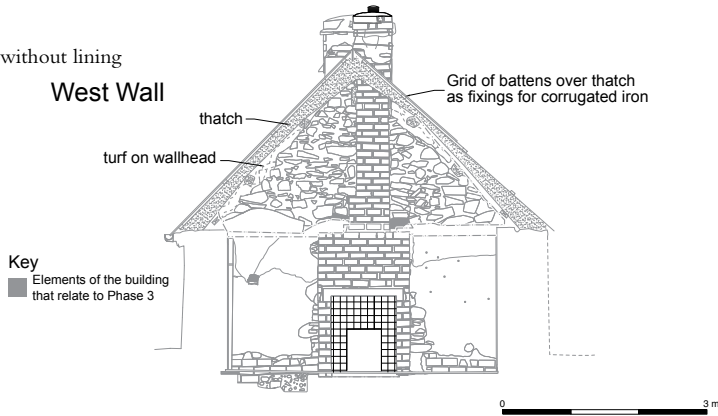

0 3 m

e) E wall

East Wall

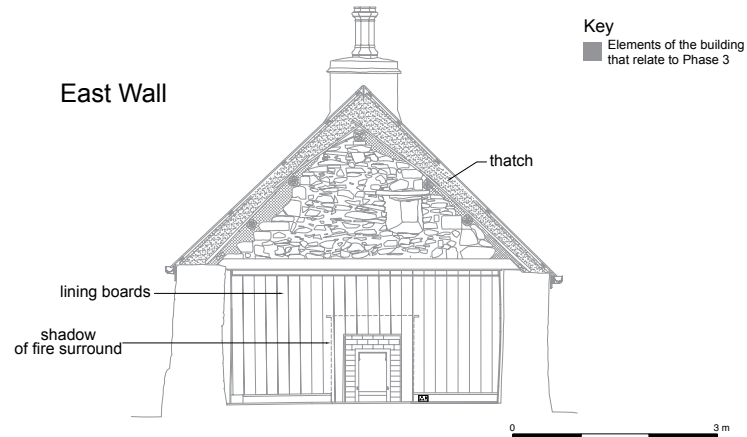

0 3 m

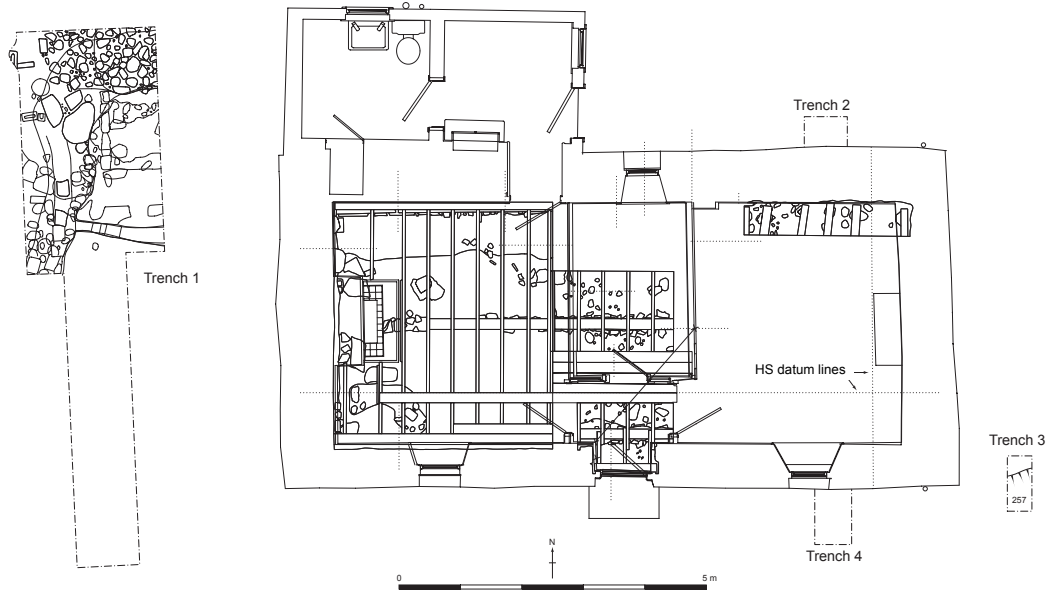
Illus. 67 Plan of excavation undertaken in and around the building

4.1 The floors and walls

Externally the walls remained as limewashed masonry much as before except that the gables were raised to meet the corrugated-iron roof. Internally, however, the floors and masonry walls were made ready for a major internal refurbishment (Section 4.3 below). Excavation beneath the current suspended floors identified that

Illus. 68 Exposed sections of the floor and N wall in the W room (Headland)

the original clay floors in the kitchen half of the house had been raked-back to retain the headroom when the suspended floors were added (Illus. 67 & 68).

All the internal walls were brought to the vertical. At the wallhead of the S wall any turf beam filling around the rafters (like that still visible today at the skew) was removed and replaced by lime mortar, brick and stonework. At the base of these walls the projecting rounded boulders of the original footings were hacked back and the exposed wall core consolidated with lime mortared stone and brickwork (Illus. 69). The internal face of much of the N wall was rebuilt sometime during this phase with lime-mortared stonework. This rebuilding probably just stabilised a failing wall although it is possible that it replaced an earlier wall constructed from timber 'backs' (see section 3.2). In any event, the rebuild removed any projecting stones and brought the wall to the vertical. It also left the NE cruck post standing proud and this had to be supported from below on bricks (see Illus. 15). Regularly spaced wooden grounds were set within the wall in preparation for the lining of the walls with sawn timber boards.

Illus. 69 Exposed section of the S wall (Historic Scotland)

4.2 The roof

During this period the thatch was raked back to accommodate the present corrugated-iron roof, probably as a part of the same general refurbishment seen elsewhere. The preparation for the corrugated sheets included the removal of any thatch at the skews and the raising of the gable masonry to their present height. The thatch over the rest of the roof was then reduced down to a level just below the full height of the raised skews. This was then used as a bed for the sawn timber framework into which the corrugated iron was screwed (see Illus. 31). This situation is often encountered with 19th-century 'tin' roofs where the basal layers of the old thatch is left to provide insulation against both sound and heat. The skews were finished with deep timber bargeboards.

The corrugated iron itself is of a standard type that could have been available from the 1840s (Walker

forthcoming) but in this part of the Highlands it was probably only used on rural buildings once the railways had been constructed. In this instance there is no evidence that it was ever painted anything other than the current traditional red. At the ridge preformed sections have been used and these were identified from trade catalogues (Braby 1893) as Frederick Braby's Eclipse patent ridge. Two types of fixings have been identified on the roof. On the main body of the Phase 3, house simple screw and washer fixings were used but on more recent areas, such as over the scullery/bathroom extension to the N, the screws were inserted through a broader diamond-shaped piece that presumably reduced the stress on the underlying corrugated sheets (Illus. 70 & 71). The roof at this time was also provided with cast iron gutters and down pipes (Illus. 72).

Illus. 70 Corrugated iron details and fixings (BW)

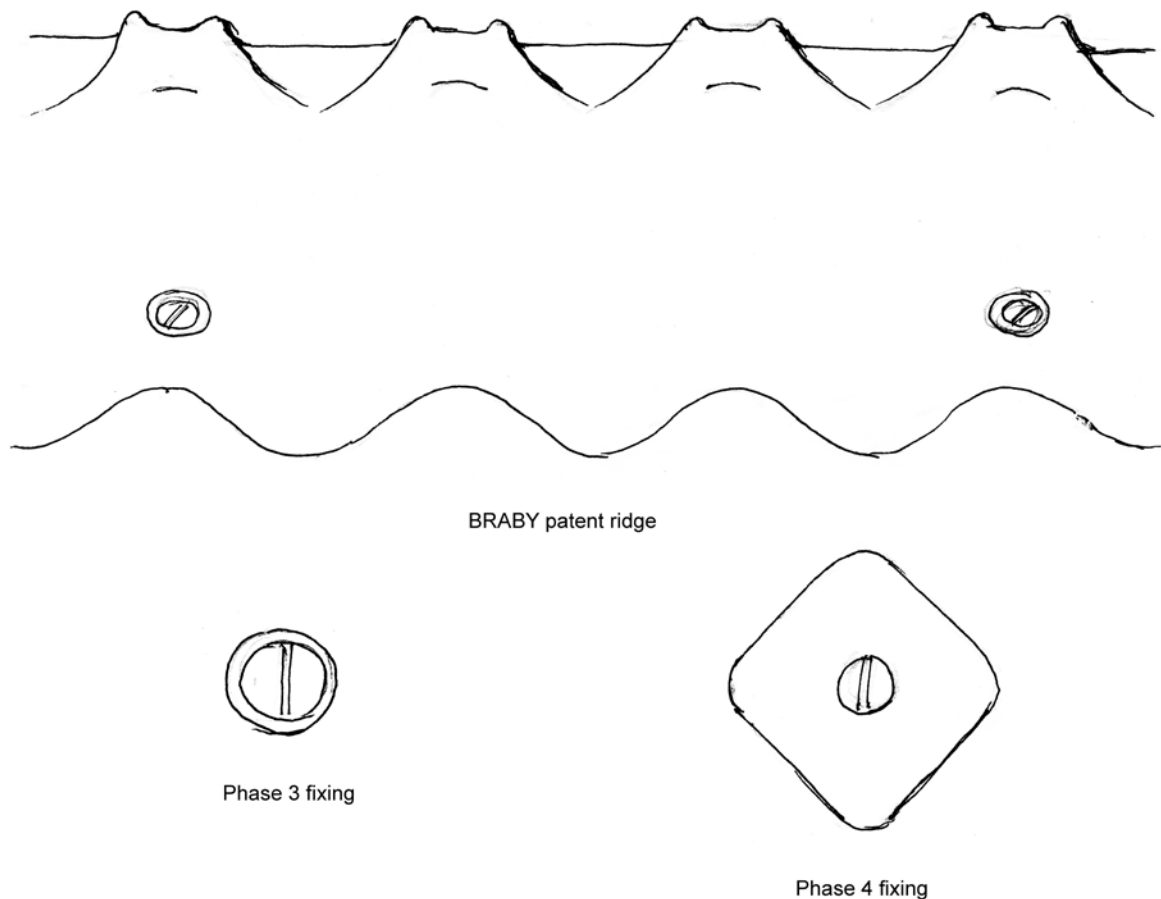

Illus. 71 Braby's patent ridge



Illus. 72

a) A brick chimney is constructed against the W gable and the height of the skewers are raised (BW)

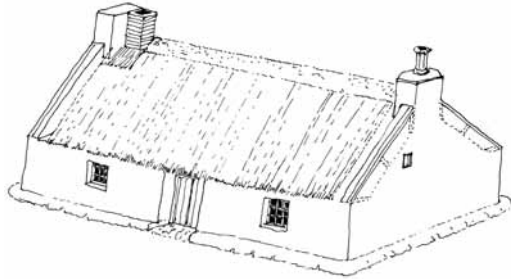

b) The thatch is raked back and a sawn timber framework laid in advance of the corrugated iron (BW)

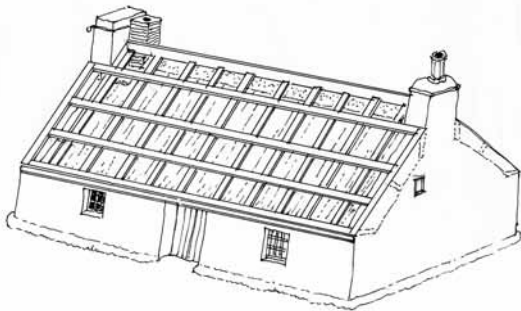

c) The corrugated iron is put on bringing the exterior close to its current state (BW)

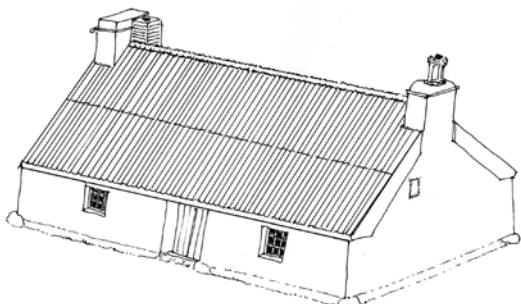

d) Rear view (BW)

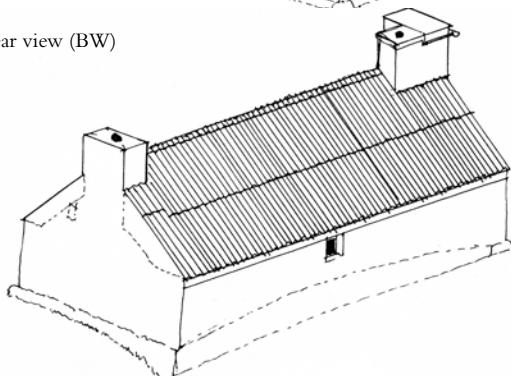

Corrugated iron

Corrugated iron is often used as an alternative to the constant attention needed to keep a thatched roof in good condition. It is uncertain whether this would have been an estate initiative, or whether it stemmed from a tenant wishing to reduce recurrent costs, or the result of the house passing into private ownership.

Catalogues were available for whole houses or individual sheets of iron from the early 1830s onwards. The Sunnybrae Cottage roof has ridge pieces patented by Frederick Brady and Co, Glasgow, Liverpool and London, but it need not have been bought new. It is difficult to establish exactly how the iron arrived in Pitlochry, and when. Whether it was purchased from a builders merchant, was spare from some other contract or was second hand, is unknown.

4.3 Internal refurbishment and layout

The main reason for straightening the walls was to provide vertical surfaces that would enable the construction of a chimney breast, stud partitions, suspended timber floors and lined walls and ceilings. The first stage of renovations required the construction of a tongue-and-groove timber floor, suspended on standard sawn joists supported by low sleeper walls of mortar and flat stones. Excavations beneath the boards showed that the original earth floors had been raked back, presumably to maintain the headroom in the newly-lined rooms, so the sleeper walls sit directly onto the subsoil. The newly laid floor covered the W half of the building abutting the timbers of the previously floored bedroom. An area in the NW corner of the bedroom where it is thought a box bed might have stood was also boarded at this time indicating that the old beds had now been abandoned.

Lining out

'Lining out' the interiors of stone-built houses and cottages was one way of improving the comfort levels.

People often refer to stone-built properties being warmer than later brick-built houses but this is not a sustainable argument. If the whole house is heated to a fairly high temperature the stone walls will eventually feel warm but the amount of heat required to achieve this is far beyond most tenants' means. Lining out the interior reduces the amount of heat required to heat a home in the short term since timber is a reasonably good insulator and the air trapped behind the lining acts in a similar way to the air space in a cavity wall.

Up until 1850, most lairds had no idea of the conditions within tenants' houses. They were often concerned with the external appearance since that made an

impact on the sense of propriety round the estate. In 1850-1 Lord Kinnaird of Rossie Priory, Perthshire and other like-minded landowners held a meeting to discuss the interiors of estate cottages. The appraising tickets and reports show that doors, windows, interior partitions and even canopy chimneys were still the responsibility of the tenant. Similarly until that date most tenanted houses remained without ceilings.

Geikie's drawings (see Illus. 63 & 65) show a range of fabric and wallpaper ceilings or planked ceilings put up by comparatively rich tenants in the houses where he slept on his tour into the Highlands in the first half of the 19th century. The quality of the furniture shows that these tenants were not poor but they would not spend money on a property when they could not recover this at the end of their tenancy.

During this phase the building was divided up into different rooms by stud partition walls. These may, however, just have formalised previous functional divisions created by the *hallen*, box beds and other furniture but formalised the arrangement of two main rooms separated by a small lobby and a closet (Illus. 73). The two rooms were now accessed from the exterior via framed doorways off a small lobby. The closet was, at this time accessed by a single doorway from the kitchen although this was eventually blocked and replaced by a door linking the lobby and closet.

The lining of the walls was done throughout with beaded tongue-and-groove boards (see Illus. 66). The

whole internal area, which had previously been lofted or open to the roof, was now given a boarded ceiling. In the W room this used the same beaded boards as those used on the walls but in the E room the beading only carries through on two boards.

The newly-consolidated walls also provided a true surface against which to construct the brick chimneybreast, flue and stack on the W gable (Illus. 74). The chimneybreast originally incorporated a cast iron range and traces of the plastered back, complete with a black lead sheen to it, was recorded when the later fireplace was removed. The range can still be remembered by some family friends even though it was probably removed sometime

Illus. 73 Plan of the Phase 3 building (HS)

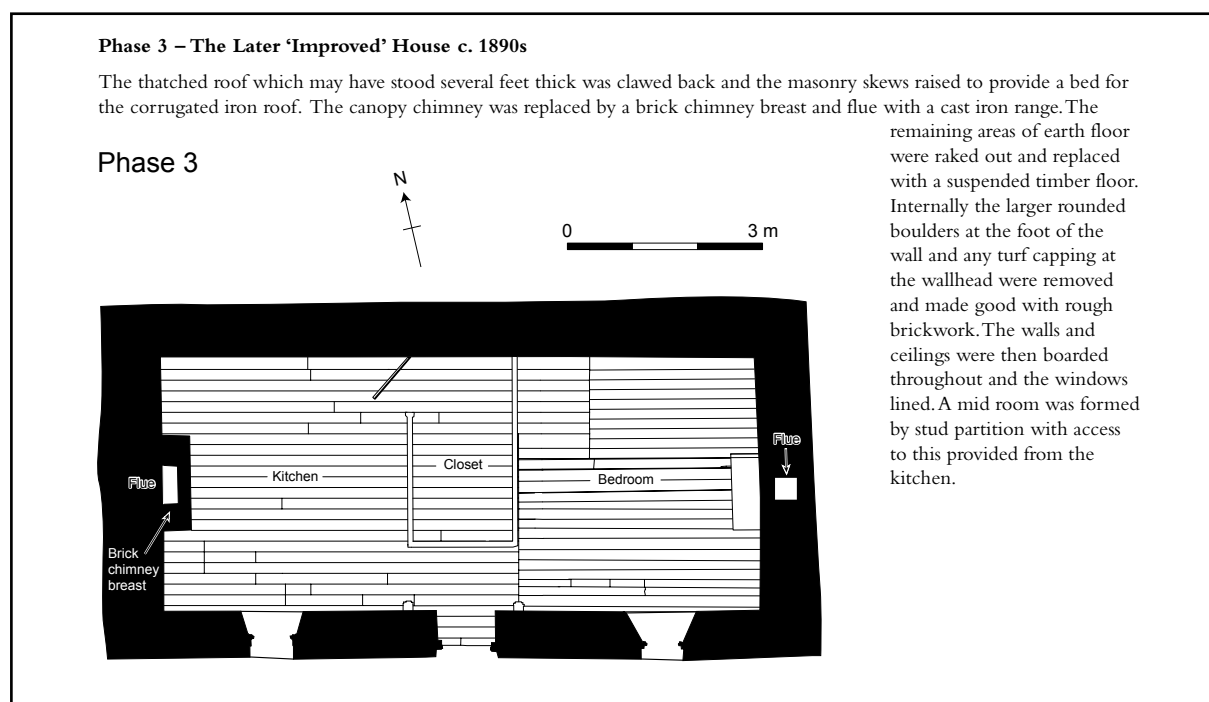

Illus. 74 The brick chimney breast against the W wall (Headland)



Illus. 76 Detail of brick chimney, corrugated iron and water tabling on the W gable (BW)

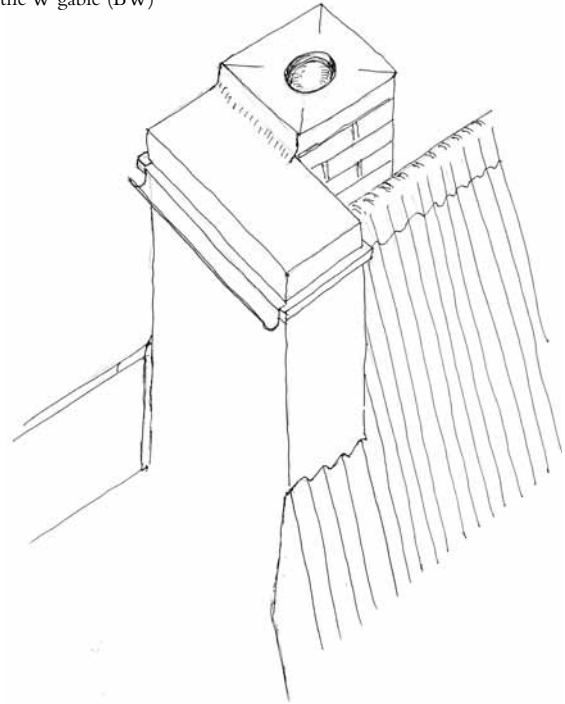

Illus. 77 Wooden boards over masonry (Historic Scotland)



in the 1940s or 50s (Illus. 75). The flue itself was lined with interlocking ceramic sections supported on two iron bars and encased within brickwork. The whole structure was fixed into the stone wall by the removal of stones and the insertion of mortared brick ties (Illus. 76). It was then lined in the same style as everywhere else (Illus. 77) and a fire surround and mantelpiece added.

The brick chimney was built using clay bricks of a commonly produced type and lacking any distinguishing marks of names. Since there was no local source it is likely that these were brought by rail from the Carse of Gowrie or Fife where there were a number of clay brick producers (Illus. 78).

Illus. 75 An example of a 19th-century range, Chapel Row Cottages, Waterside, Ayrshire (SCRAN)



Illus. 78 Reconstruction showing
a) The S elevation (HS)

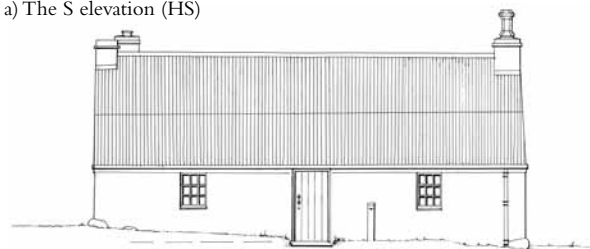

b) The W elevation (HS)

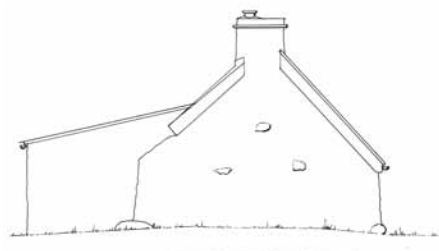

Imported materials

The railway system affects the choice of building materials throughout Scotland and permitted merchants to import inexpensive materials from anywhere in the British Isles (Illus. 79).

Illus. 79 Station, Pitlochry, Perth & Kinross, looking north-west 1976 (SCRAN)



In the case of corrugated iron, the catalogues produced by the manufacturers stated that all prices included transportation to any mainland railway station. Similar arrangements may have been in place for the delivery of bricks.

The answer to when did plaster supersede limewash depends on the wealth of the householder and the distance from the lime kilns. Certainly in the early 19th century sanitary inspectors insisted on the bigger dairies being limewashed every six months to cut down the risk of infection in the milk, butter and cheese. The houses of the rich had been plastered either with lime or clay-plaster from much earlier, but with the inspectors' visits, the material became more available and many farmers began to limewash their houses to improve the appearance and cleanliness.

4.4 Furnishings

After the lining out of the interior of the house the furnishings would have been much more individual following the fashion of the day, when the occupants were young (Illus. 80 & 81). The style would in all likelihood have gone out of fashion as they aged. The box beds were removed at the time of the lining out and were probably replaced with freestanding beds of iron or wood. The only real evidence for the decorative style

Illus. 80 Reconstruction plan of the Phase 3 building (BW)

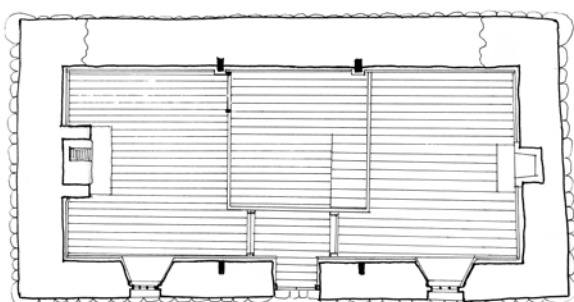

Illus. 81 Reconstruction section and elevation showing the range in the W room (BW)

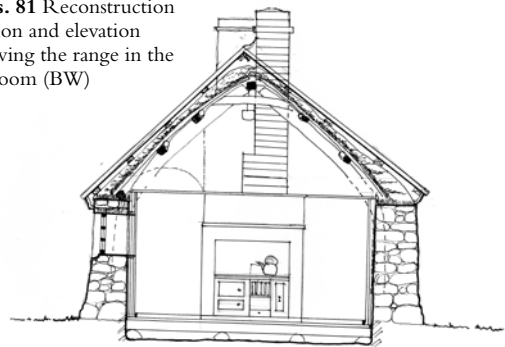

were patches of surviving wallpaper and the 'shadows' on the wall formed by hanging photographs, pictures and calendars. Some of the wallpaper samples recovered certainly belong to this period so it is unclear how long the timber-lined walls remained exposed. The earliest wallpapers applied were typical of the 1890s and were stuck to a cotton textile lining that had been nailed to the boarding. Both this and subsequent papers were high-quality floral patterns typical of the late 19th early 20th century (Illus. 82). This may indicate a sophisticated taste by the occupants or possibly an association with the adjacent Sunnybrae House. Some of the floorcoverings identified could also belong to the latter part of this phase and these are discussed later (Table 5).

4.5 Discussion of Phase 3

The Phase 3 house takes the form of a small single storey symmetrical "improved" style house broadly conforming to the symmetrical principles in keeping with 'modern' estate architecture of the second half of the 19th century. In Pitlochry, a small farmhouse or cottar house is unlikely to be "improved" much before the 1880s although the then owner, Mr Anderson, was an incomer and may have had more advanced ideas than the local estates. Little had to be done in this case since the door was almost central on the house façade and the windows were evenly spread on either side. The extension to the W could have been removed to heighten the sense of symmetry.

Illus. 82 Wallpaper samples.



- a) Cream wallpaper with yellow and pale green floral print including primroses. This type of floral design was popular in the 1890s and early 20th century
- b) Cream wallpaper with green and maroon floral print. The combination of wallpaper and border is typical of the early 20th century

It is obviously a good quality scheme and is similar to several others dating from 1900-1914.

The turf at the skewers was removed and the masonry wall extended upwards. The thatch would then have been clawed back to accommodate the framework for the corrugated iron. The iron itself was carried over the raised skewers and the skew furnished with a deep timber bargeboard as was common in the lowland areas of Perthshire.

The brick chimneybreast, and the brick underpinning of the walls where the projecting base course was removed was from this time. It would seem logical that all the work carried out using the red clay bricks was of one period. The timber lining of the interior was part of this phase as was the installation of a cast iron range in the brick chimneybreast.

The façade retains a single doorway flanked by two windows now sitting within timber-lined embrasures. The remaining areas of earth floor were replaced by suspended timber flooring, tongue and groove boards, supported on 6 x 2 inch (13 x 5.5 cm) sawn joists.

Internal space of the cottage was divided using stud partition walls to create a kitchen (W room) and

bedroom (E room) separated by a closet and lobby. This phase also sees the removal of the canopy chimney and its replacement with a cast iron range and brick chimneybreast/flue against the W wall. The internal walls were lined throughout with timber boards and all the rooms were provided with ceilings.

This phase must post-date 1861 because a fragment of newspaper from this year was removed from the limewash beneath the wooden panelling on the N side of the fireplace. It would seem most likely that it was a new owner of Sunnybrae Cottage, Mr Arthur Anderson, who was responsible for the renovations. Mr Anderson was, after all, the Inspector general of Hospitals and is likely to have had an interest in reforms of this type. He had also just completed the construction of the adjacent villa, Sunnybrae House and was certainly resident there by 1871. It is unlikely that somebody could have lived in the cottage while such significant building work was being undertaken, so the most obvious time for such an improvement would be during a change in tenant. This happened a number of times between 1871 and 1896 (see Table 3) so it is to this period that the renovations are presently attributed.

5 20th-CENTURY HOUSE – PHASE 4

(Extension, and internal plumbing – 1940s-1990s)

5.0 Introduction

The 20th century saw a number of changes, primarily to the interior of the cottage, in order to keep pace with standards for modern living (Illus. 83, 84, 85, 86). A small

extension to accommodate a bathroom and kitchen was constructed against the N wall, the walls were lined with plaster board and modern services and central heating installed.

Illus. 83 View from the N 1998 (Historic Scotland)



Illus. 85 The hearth in the W room 1998 (Historic Scotland)



Illus. 84 View from the S 1998 (Historic Scotland)



Illus. 86 The E room looking towards the front door 1998 (Historic Scotland)



Table 4 – The owners and occupants of Sunnybrae Cottage 1934-1998

Date	Owner	Occupier	Comments
1934/5	On the death of Miss Annie Cameron , the title of Sunnybrae Cottage reverted to Thomas M Nesbit .	The cottage stood empty from 1935 to 1936 and was then tenanted by Miss Annie McDonald from 1936 to 1945.	
1945	Mary R Nisbet , the then owner of Sunnybrae House, and Susan Annie Kerr (nee Nisbet) .	Annie McDonald	Mary and Susan were daughters of Thomas Nisbet
1945-86/7	Jane M Macdonald (nee Storie and known as Jean) purchased the property outright in 1945 from Mary R Nisbet the then owner of Sunnybrae House.		Jane was the wife of Alexander Macdonald , Painter, Delta, Pitlochry
1986/7-1998	John S Macdonald either purchased or inherited the cottage after the death of Jane Macdonald .		
1998-present	Historic Scotland on behalf of the Scottish Ministers purchased Sunnybrae Cottage on the death of John Macdonald .		

As a part of the project Mr William Higgins of Wishaw was interviewed to record what he remembered about the cottage. He was the cousin of John MacDonald, the last occupant of the cottage and he used to spend holidays at the cottage with John (then a small boy) and his aunt and uncle, Jean and Sandy MacDonald. His first memories of the property were probably just before World War II and Mr Higgins continued to visit the cottage into the 1990s. He remembers very little change and described the house as a ‘timewarp’, never giving any thought to the small size; a nice house where he was made welcome.

In his memory the building was always whitewashed and red tin roofed. There was a cooler at the NE corner outside for milk and butter. They grew flowers in the garden but probably not vegetables. In the 1950s, Jean also took in lorry drivers and put them up in a wooden lean-to and ‘chalet’ against the E end of the N cottage wall, ‘behind the big bedroom’. The huts for the truckers were small wooden lean-tos with a single bed (see Illus. 84). She charged 5 shillings for bed, dinner and breakfast in the summer.

5.1 The brick extension and other structural works

The changes that had the most impact were the construction of an extension against the N wall and the

insertion of a window in the N wall. (Illus. 87a-d, 88). These we know were undertaken in the late 1940s or early 1950s because a proposal for works was discovered along with the deed to the property (Illus. 89). The improvements proposed were mostly carried-out and include the following:

- Supply and build in kitchen grate with HP boiler
- Slap opening through the N wall to extension and fit with door
- Slap opening in N wall of mid room and fit with window Erect brick extension 6’ x 15’ with bathroom and scullery
- Strapped and finished with plasterboard throughout
- Fitting of two new windows – upper parts hinged to open

This extension was built of composition brick and had a corrugated-iron roof that dovetailed perfectly with the original 19th-century roof. It was built with two rooms, a bathroom to the W and a walkthrough scullery/ kitchen to the E. A door to the outside was provided from the scullery and a trial excavation along the N side of the building suggested that the present graded pathway involved the removal of topsoil and a degree of landscaping along the N and NE edges of the plot (Illus. 90).

Illus. 87 Phase 4 Survey drawings
a) N wall (HS)

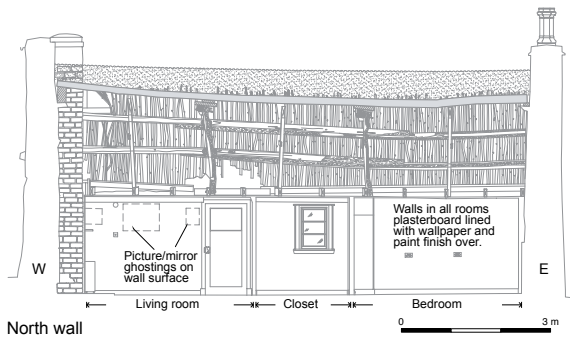

b) S wall (HS)

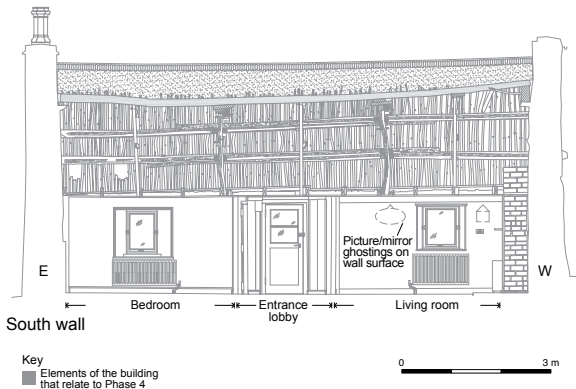

c) W gable (Historic Scotland)

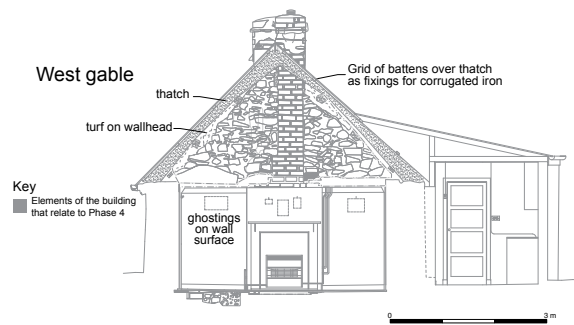

d) E gable (Historic Scotland)

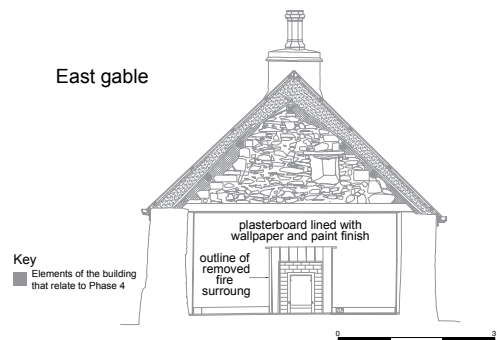

Illus. 88 Plan of the cottage (LP)

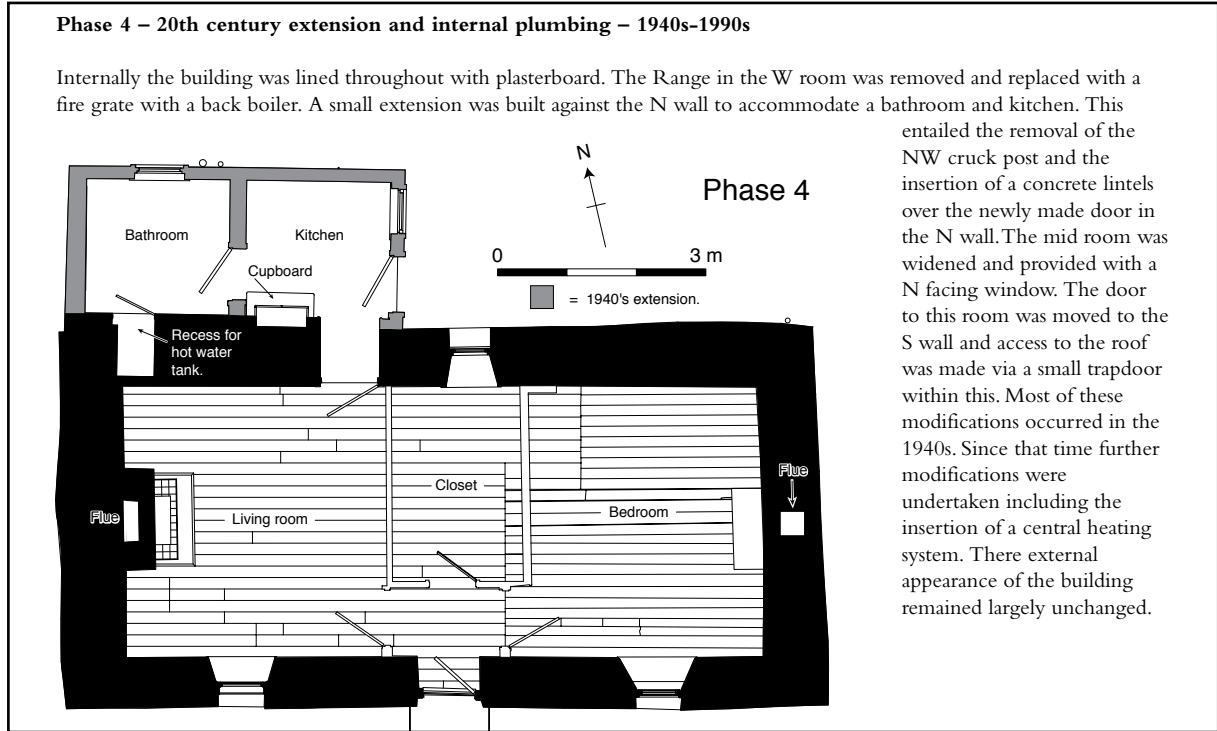

Illus. 89 A brick extension is built against the N wall (BW)

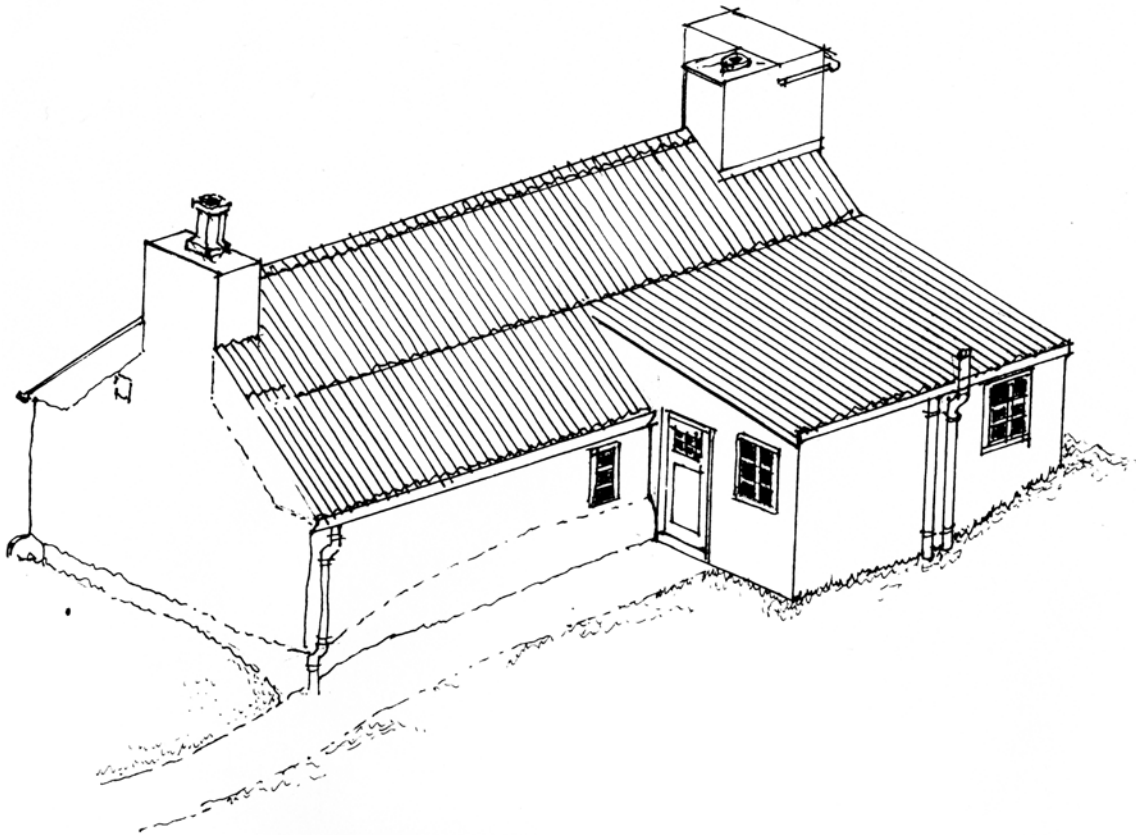

Illus. 90 Costed proposal for work 1945

105

ROBERT GOW.
Joiner and
Contractor.
Telephone:
214 BLAIR ATHOLL.

BRIDGE OF TILT,
BLAIR ATHOLL,
June 1st 194

Miss Smith
Delta
Pitlochry
Madam

Proposed improvements to Sunnybrae Cottage for Mr. MacDonald

I herewith submit detailed specifications of work as proposed and discussed

Supply and build in Kitchen Grate with M P Boiler and Scour taken out through Gable

Slap opening in Back wall of Kitchen with door complete

Slap opening in Back wall of Mid Room and fit window complete

Supply and erect brick-built building behind Kitchen 15' long by 7' wide with 7.6 ceiling room

Bathroom with Bath, Basin and W.C. Scullery with Tub and Sink all with Hot and Cold supplies drainage to main Sewer with all Traps complete

Strapped inside and finished with X Gyproc Plaster board on all walls and ceilings

Back door to scullery door to Bathroom all complete

Two new Windows with upper parts hinged to open Roof of couples sacking Felt and asbestos Slates etc all finished complete and left in working order

To carry out this work as detailed above would cost approximately £280 sterling

Yours faithfully
Robert Gow

Transcription of the letter above

Madam

Proposed improvements to Sunnybrae Cottage for Mr. MacDonald

I herewith submit detailed specifications of works as proposed and discussed

Supply and build in Kitchen Grate with M P Boiler and Scour taken out through Gable

Slap opening in Back wall of Kitchen with door complete

Slap opening in Back wall of Mid Room and fit window complete

Supply and erect brick-built building behind Kitchen 15ft long by 7ft wide with 7.6 ceiling room

Bathroom with bath, basin and WC. Scullery with tub and sink all with Hot and Cold supplies, drainage to main sewers with all traps complete

Strapped inside and finished with X Gyproc plaster board on all walls and ceilings

Back door to scullery, door to Bathroom all complete

Two new windows with upper parts hinged to open. Roof of couples sacking. Felt and asbestos slates etc all finished complete and left in working order

To carry out this work as detailed above would cost approximately £280 sterling

Yours faithfully
Robert Gow

The new scullery, now a modern kitchen, was accessed from the inside via a newly made doorway through the N wall (Illus. 91). This involved the removal of the NW cuppill post which, in turn required that the sile above be supported by a timber joint and two concrete lintels over the doorway. A new piece of timber has since been spliced to the blade and its base supported on a steel support. The cheeks of the doorway as well as a large area of the original N exterior (now the S wall of the kitchen/bathroom) wall were consolidated and brought to vertical using composition brick and cement.

The same proposal costed for slapping a window through the N wall into what was then a closet. This too was carried out and splayed window was formed, consolidated with brick and lined with timber.

The extension utilized composition bricks, that is bricks made from crushed shale, clay and coal waste. The bricks are stamped 'LOCHSIDE'. This was a brickworks in Fife close to Dunfermline. The company producing these was the Lochside Coal and Fireclay Company Works, Townhill, Fife (NGR NT 102891) which operated from c. 1902 to 1974 (Douglas and Oglethorpe 1993).

Composition bricks

A type of common brick made using a mixture of clay, coal waste and shale. The fired bricks were normally yellow in colour but with darker patches which appear to reflect the way they were stacked in the kiln. The date when they were first made is unknown but they are likely to have been a response to the shortage of building materials after World War I. They ceased being made when the Scottish coalfields closed down.

Other works undertaken between World War II and the 1990s include full lining-out of the building with

Illus. 91 A typical post-war scullery – No 32 Maidencraig Crescent, Edinburgh (SCRAN)



plasterboard. This was nailed directly to the timber lining beneath. The range in the W room was replaced by a gas fire and a central heating system was installed. This included the insertion of a gas-fired boiler in the wall between the bathroom and living room and a hot water tank in the loft (see Illus. 5).

Externally the house changed little although the windows in the S wall were replaced with centre pivot windows that would have been typical of the 1970s.

5.2 Internal layout

With the insertion of the N-facing window the layout of the closet was also altered.

The original door in its W wall was blocked up and a new doorway formed in the S wall where it opened directly onto the lobby. A line of varnish/polish on the present timber floor indicates where the E stud wall originally sat. This was evidently dismantled and rebuilt 0.25 m to the W so increasing its size considerably. The new partition wall evidently reused the materials from the demolished wall because many of the planks in its double skin retained several layers of earlier wallpaper and paint. In this new form what was originally a closet could now easily have been used as a second bedroom.

The requirement for internal plumbing in a separate kitchen and bathroom brought about the extension of the cottage in the mid-20th century. Since this time the walls were lined with plaster board and central heating put in. By the 1990s it was, for all intents and purposes, a small but comfortable four-roomed cottage.

Other changes undertaken at about the same time include the insertion of a boiler in the thickness of the N wall and the lining of all internal walls with plaster board so covering numerous layers of earlier wallpaper. The E gable loft window was bricked up and the range in the W gable removed and replaced with a more contemporary tiled fire surround (see Illus. 85). Presumably some time in the last quarter of the 20th century, a central heating system was installed to bring it to the condition in which it was purchased by Historic Scotland.

5.3 Furnishings

The furnishings during the 20th century probably changed several times according to ownership and fashion. At the time of purchase by Historic Scotland the furniture had already been removed, but Mr William Higgins remembers that the cottage had three rooms: a living room, small bedroom and a larger bedroom. In the living room, Jean Macdonald had a seat or bed in the NW corner of the living room. There was a further sofa in front of the fire. By the window was a dining table and the television was in the SW corner. The fire at this time was a gas fire put in by John perhaps in the 1940s or 50s. Latterly Sandy Macdonald stayed in the

box room, John in the larger bedroom although the larger room was apparently also used for B&B accommodation. There were two single beds in the E room and a wardrobe in the NE corner. The two beds had their heads against the N wall.

Mr Higgins talked about how low the ceiling was and how easy it was to whitewash. The walls were wallpapered and it ran onto the roof ‘almost like a cave’.

5.4 Floorcovering and wallpapers

Samples of the floorcoverings at the point where Historic Scotland took over the property were taken and compared with modern reference material. Seven different patterns of covering were identified and these were in circulation from the 1920s until the 1970s therefore some could potentially relate to Phase 3. Only one sample was actually linoleum. The remainder were felt-based coverings made of felt saturated in bitumen. Some were given the name ‘Brunofelt’ or ‘Congoleum’. These were cheaper to produce than linoleum but were brittle and easily cracked (Illus. 92).

Table 5 – Floor coverings

Item no.	Description
(1+2)	Two samples of felt-base floorcovering (85 by 87 cm and 95 by 87 cm). Floral design on geometrical background. Mark on reverse: ‘Brunofelt. Made in Scotland’. Dates from mid 1930s to early 1950s. ‘Brunofelt’ was the trade name used by Nairn’s of Kirkcaldy for one of its felt-base floorcoverings. It was made in Kirkcaldy from the mid 1930s. Production of ‘Brunofelt’ stopped in the war years and re-started in 1948.
3	Sample of felt-base floorcovering (85 by 97 cm). Floral design with abstract triangular pattern. Mark on reverse: ‘Made in [England]?’ Dates from circa 1940s/early 1950s. Possibly made in Lancaster.
4	Sample of felt-base floorcovering (91 x 97 cm). Abstract design. Tear in middle, hole near one corner and part of corner separated from main sample. Dates from 1940s/early 1950s.
5	Sample of printed linoleum (75 by 30 cm). Abstract design with jute canvas backing. Dates from 1940s/early 1950s.
6	Sample of vinyl (98 by 80 cm). Stone/marbled design. Dates from 1960s/early 1970s.
7	Small sample of felt-base floorcovering. Dates from circa 1930s to 1950s.

Illus. 92 Floorcoverings

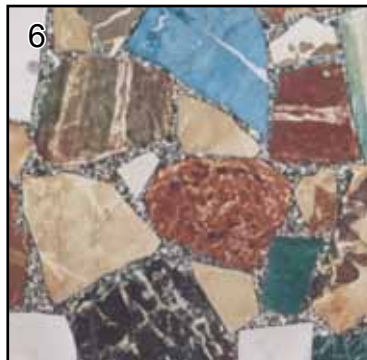
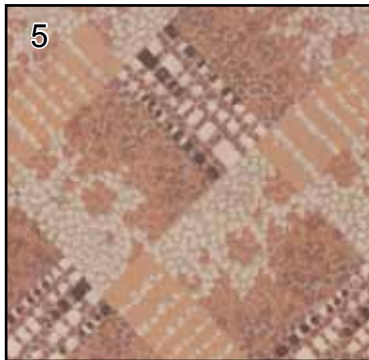
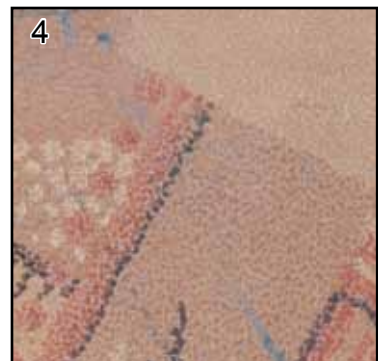
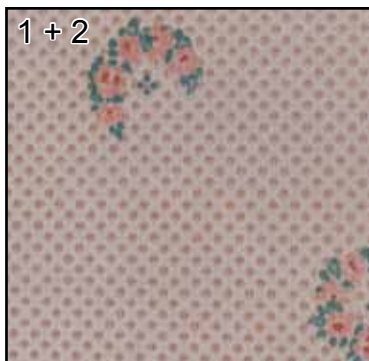

Numerous wallpaper fragments were taken which probably relate to this period (see Table 6) (Illus. 93). The earliest wallpaper samples date from the late 19th century by which time the house had attained its final layout. The last sample appears to date to the 1950s or shortly afterwards. The most complete stratigraphic series was found in the bedroom, which yielded sequences of between five and ten layers in four locations. The most complete sequence was found underneath a window sill and dates from c.1880/1890 to c.1950. The samples were analysed off-site by Allyson McDermott, an expert in the research, conservation and care of historic interiors. The bracketed numbers refer to the context numbers given by Headland Archaeology.

The earliest paper in the bedroom, found under the sill and on the east wall has a pink background with a pale green and white floral print (01). This is a block printed wallpaper on a machine made, short-fibred wove paper. The sample consisted of a total of seven fragments and in all cases was stuck to a cotton textile lining. MacDermott (2006:2) notes that this might have been intended to imitate contemporary silk damask, perhaps in the Japanese style. This phase may be associated with the purchase of the property by Arthur Anderson. As noted in the previous chapter, this phase saw a major refurbishment of the building and modernisation of the internal space. The quality of this paper is perhaps an indication of the sophistication of the occupants or owners of the property. Surviving evidence does not permit the attribution of an agent to the furnishing of the late 19th-century property, although Mr Anderson's social and economic situation seem to suggest that he was responsible for the improvement of the interior

rather than the tenants. It is unclear which tenant lived in the cottage when the refurbishment took place.

Overlying the pink floral paper (01) is a cream and yellow floral print (02), also present in seven fragments. This was noted under the window sill in the bedroom and on the east and south walls. In the case of the south wall it was directly over the linen with no underlying pink floral paper. MacDermott (2006:3) concludes that this paper is more likely to date from after the turn of the century when the fashion for breaking up the wall surface changed from skirting to ceiling schemes. At this time, David Murie Stewart owned Sunnybrae, but it was occupied by Ann Cameron and her daughter Annie Cameron after the death of David Cameron in 1896. By this time, the major renovations on the property had ceased and furnishing the house was probably the responsibility of the tenant. This cannot be stated with certainty, as there is currently no hard evidence of agency. However, the frequent changes of style which would characterise the early 20th-century sequence are suggestive of choice rather than necessity. They suggest the hand of someone who considered their surroundings to be an important reflection of their own style and how they were perceived.

It might be hypothesised that the new wallpaper (02) and subsequent papers until the mid 1930s were added by Annie Cameron. She was designated proprietrix in 1900 and was seemingly the youngest and most able member of the household at this time. The associated border uses good paper and features high-quality block printing (MacDermott 2006:3) and the choice of this style is seemingly an indication that the occupiers were

Illus. 93 Wallpaper samples

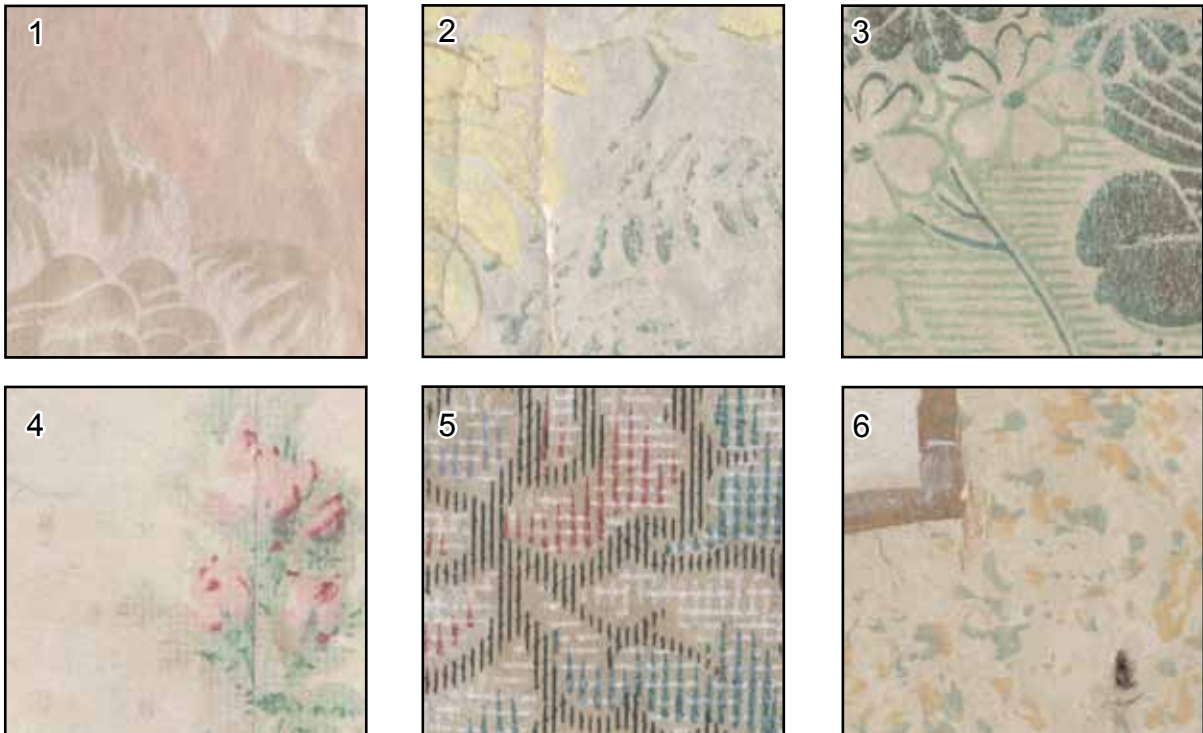

aware of changing fashions in interior furnishings and endeavoured to keep themselves up to date.

Between 1900 and 1930, the wallpaper scheme changed at least four times. This further suggests that Annie Cameron, who was tenant throughout, maintained an interest in keeping her furnishings up to date. MacDermott (2006:5) singles out the six fragments of cream wallpaper with green and maroon print (03) as evidence that the occupant of the cottage was sophisticated and ‘artistic’. This dynamic ‘art nouveau’ pattern (MacDermott 2006:7), probably added between 1900 and 1914 when the tenant was in her late 40s or 50s, might be contrasted with the more sedate and homely wallpaper which immediately overlies it. This cream wallpaper with pink floral bouquets is interpreted by MacDermott (2006:7) as a homely design which was popular after World War I, popular in country houses. This sedate design may suggest a change in the mindset of the occupant of the cottage, perhaps brought about by growing older or some other imperceptible change to how she regarded herself which was made manifest in her surroundings.

The next paper in the sequence below the window sill is an abstract patterned wallpaper (5) which MacDermott (2006:8) recognises as imitating textile. This type of patterning might have been produced anytime from c.1870 until the mid 1920s. It is the last wallpaper which can be associated with Annie Cameron’s tenancy and is a departure from the other samples, being less dynamic and fashionable and more a traditional and timeless style. It is less suggestive of a concern with fashion than the earlier samples and implies a corresponding change in the attitude of the person who chose this pattern.

Annie Cameron died in c1935 and the cottage was subsequently tenanted by Annie MacDonald from 1936 to 1945. It was at around this time that an in situ splatter paint on white paper covered the walls of the cottage. This was present in nine fragments and can be definitively identified on the north bedroom wall, east bedroom wall and sill under the window. It is tempting to associate this change with the new tenant, Annie MacDonald. This type of wall covering was fashionable in the 1930s and 1940s (MacDermott 2006:6), but was also personal, as it was applied in situ and was therefore unique.

MacDermott (2006:11) affirms that the three textured papers, a pale olive green paper (7), an embossed paper with offset circles (8) of contemporary date and an embossed flower pattern (10) are the latest papers in the sample. The olive green paper is present on all walls in the bedroom and under the sill. The offset circles were only noted under the sill. All of these papers date after 1945 when Jane MacDonald purchased the property and both owned and lived in the house until the 1980s.

In its incomplete state, the sequence of wallpaper samples preserved at Sunnybrae Cottage are still capable of giving a good indication of changing fashions and preferences of the owners and occupiers of the Sunnybrae. Based

on available evidence, the attribution of agency is necessarily tentative. However, the dates put forward for the samples and their stylistic qualities do allow for reasoned speculation. The wallpaper samples therefore provide a crucial insight into the identities of ordinary people associated with the cottage, preserved on the walls after all other traces of individuality have been lost.

Kirsty Owen

Table 6 – Wallpaper samples

Item no.	Description
1	Earliest wallpaper by stratigraphy. Pink background with pale green and white floral print
2	Cream wallpaper. Yellow and pale green floral print including primroses
3	Cream wallpaper. Green and maroon floral print
4	Cream wallpaper. With vertical linear pattern of pink floral bouquets on blue and beige columns. Discreet circular dotting pattern in background
5	Abstract patterned wallpaper. Aquamarine, claret and mustard yellow floral pattern emphasized by black outlining and white highlighting. Textured print using vertical and horizontal cross hatching effect
6	Paint on blank paper. Laid directly onto layer 5. White-painted base, with sponge or rag-rolled random paint pattern in green on top of yellow
7	Textured wallpaper. Painted pale olive green, same stratigraphic level as 8
8	Textured wallpaper. Heavily embossed with rows of 0.005 m dia. offset circles, forming a rhombus effect. Four petalled abstract flowers form a background relief in the spaces between the circles, in a similar rhombus arrangement. At least four coats of paint are present, the first three being white or off white, the fourth (upper layer) being the same pale olive green as seen on layer 7
9	Textured wallpaper. Bas relief abstract floral pattern, unpainted (fragment was behind a skirting board) traces of rose pink pigment are visible on the uppermost edge
10	Textured wallpaper. Heavily embossed with a bold pattern of flowers inside geometric shapes. Columns and rows of two styles of circle form a paired rhombus pattern, interspersed with four-pointed stars. Below 10 is a fleur de lis and zig zag pattern, not properly exposed
11	Paper fragments from the top of a cruck post. Blue, grey and white diamond pattern, with floral aspects may be wallpaper or wrapping paper. Also newsprint pieces, fragmentary. Two datable bits 14-7-1847 and 24-4-1851

5.5 Discussion of Phase 4

Phase 4 sees the house being repeatedly being brought up to scratch in keeping with modern standards of living. Firstly, the requirement for internal WC, Bathroom and Scullery was accommodated by the construction of the brick extension to the rear. Later the walls were lined, gas-fired central heating was installed and to all intents and purpose the cottage was a well-maintained comfortable modern home.

6 1998 TO THE PRESENT

The first step once Sunnybrae Cottage came into state care in June 1998, was to create a full record of it and discover more about its building development. This is required before proposals can be drawn up to present the cottage to visitors as accurately and sensitively as possible. Historic Scotland has consulted widely with interest groups, such as the Moulin and Pitlochry History Circle, and neighbours during the recording process. Regular tours and talks have been coordinated to update local people on progress and to facilitate public access. Temporary information panels have been erected in the garden for the benefit of passing visitors. Equally, the History Circle and locals have helped with the research. This chapter will summarise all the recording and conservation work that has been undertaken at, research and research about, Sunnybrae Cottage since 1998.

The condition of the whole site was photographed when it first came into care and a measured survey was carried out in the October by a team of Historic Scotland architectural technicians. Some items were then moved to facilitate the survey, including, carpets, hot/cold water tank and loft insulation. In the following April, Historic Scotland's Conservation Centre carried out some borescope investigations to establish what lay behind the timber lining, particularly around the boxed-in cruck in the W room (see Illus. 6). Samples of wallpaper and floorcoverings, newspaper fragments, and a bottle cork were removed at the same time. The National Maritime Museum was contacted to find out more about a newspaper fragment from the N blade of the W cruck which referred to the launch of the battleship 'Agamemnon' and the floorcovering samples were sent to Kirkcaldy Museum and Art Gallery to be identified. It was also important to re-establish service tracks; these investigations were monitored by Kirkdale Archaeology and Headland Archaeology along the N boundary wall.

To enable more information about the cottage to be recovered, it was provided with all-weather protection using a specially-designed scaffold with its own roof covering and incorporated areas of safe visitor access. It was erected in September 1999 after securing Planning Permission and remained in place for four years (see Illus. 8) and the other sheds around the cottage were carefully dismantled and stored off-site. This phase of work consisted of the detailed recording of the internal wall, floor and ceiling finishes, the solum beneath the

suspended timber floors, the recording and removal of the brick chimney flue, and the recording of the cruck-framed roof structure, the corrugated iron and the surviving thatch beneath it. Headland and Historic Scotland staff from a range of departments worked together to achieve this.

Sections of corrugated iron were photographically recorded before they were carefully removed and stored. Areas of thatch were archaeologically excavated (see Illus. 31 & 32) and the voids filled with geotextile and insulation matting over the winter. In May 2000, areas of timber wall linings and floorboards were removed and stored so that what lay beneath could be recorded. Meanwhile, Headland compiled a list of historical data sources about Sunnybrae Cottage and comparable structures. Analysis of the roof helped to show that the corrugated iron had protected its original covering of turf and rye thatch and so it was felt that these remains should continue to be covered, and by the same material which had its own historical significance (see vignette on corrugated iron, 4.2). Further work was carried out on the samples of thatch by the University of Stirling and samples of the roof timbers were taken by AOC Archaeology for dendrochronological analysis to see if the date of the earliest structural parts of the cottage could be established (see vignette on dendrochronology, 2.2).

The next phase of archaeological work began in 2002. This consisted of further investigation behind wall linings and around the internal door to the kitchen, and excavation of trenches within the cottage in an attempt to establish the original floor level and finish. Further trenches were dug outside to try and identify foundation levels and the complete extent of the footprint of the cottage. Another piece of newspaper fragment with a date, 1863, was discovered in the W room. Carpenter Oak & Woodland were asked to provide information on the cuppills and, in particular, the cut marks found on the siles (see Illus. 21 & 22). The finds from the investigations have been catalogued and stabilised, and are currently stored by Historic Scotland's Collections Unit (see appendix Finds List).

In tandem with the archaeological investigation and recording, Historic Scotland developed a maintenance regime for the cottage and monitored the condition of the structure. For example, various samples were taken

so that the most appropriate mortar mixes could be specified. Mortar samples were sent to the Scottish Lime Centre for analysis and Historic Scotland's Conservation Centre analysed the limewashes and paint from the corrugated-iron roof. In 2001 it was discovered that some of the timbers were being damaged by furniture beetles and this infestation was tackled using traps. Once the area of plaster and brick around the kitchen door had been dismantled, the NW cruck was supported with a temporary prop and Carpenter Oak & Woodland were asked to design a new cuppill base as well as two new collars to replace those removed. The new post was fitted in November 2005 together with a steel shoe to provide a seating (Illus. 94). The excavation of the area of floor required to create a concrete foundation for the shoe was monitored by Headland.

Illus. 94 Cuppill base and steel shoe (Historic Scotland)



Before the scaffold shelter was dismantled in September 2003, the masonry walls, skewes and chimneys were consolidated by Historic Scotland's Monument Conservation Unit and limewashed. The timber battens, ridges and bargeboards were repaired, the corrugated-iron sheets were reinstated and painted, and lead flashings were installed around the chimneys. The NE corner of the cottage had been undermined by earlier ground cutting exercises and so, at the same time, a ballast of hardcore was post in place to support it. Repairs and

painting of doors and windows and grass-cutting are part of the ongoing maintenance regime.

Ideas about how to structure the final publication of the excavation and research about Sunnybrae Cottage were first discussed at the end of 2001. A first draft was prepared by the main authors in 2003 based on an 'Archaeology', 'Materials' and 'Reconstructions' structure with various forms of evidence, such as archaeology and ethnography, treated separated. After some rethinking, a sample section was prepared following a structure of chapters based on building phases, rather than building element, with vignettes on materials and methods and, later, a typeset example was produced. To try and find out more about the 20th-century history of Sunnybrae Cottage an oral history project was undertaken by Headland in 2005 following up various leads that had been suggested previously. The final piece of post-excavation work, a more detailed analysis of the wallpaper fragments, was carried out by Allyson McDermott in 2006. A short interactive movie of the interior of the cottage was also produced by Headland in 2005 with a view to this enabling 'remote access' until it could be opened to the public on a more regular basis.

Together, the detailed recording, analysis, excavations and research, of Sunnybrae Cottage has helped to reveal a great deal of information about what it may have first looked like and how it has changed over the last 200 years or so. A great many individuals have helped to get us this far. The work has reaffirmed that the cottage is a rare survival; something that has been formally recognised for over fifteen years. It was Category B-listed in 1991 and so was at that time considered to be of regional significance. It was later re-evaluated as being of national significance by being Category A-listed in 1998. After it was taken into state care, itself a measure of its value, it was also designated as a scheduled ancient monument in 1999. This confirmed its national importance but also recognised the value of below-ground archaeology under the cottage and in its garden. Since 1998, the cottage has been cared for and regularly inspected by Historic Scotland, in particular, by the Monument Conservation Unit staff based in Perth and all the linings, floorboards and timber sheds removed from the site to facilitate recording have been stored. Now that the results of the archaeological and recording work have been pulled together in this publication, Historic Scotland has formed a project team to begin to work out how to best present the cottage to the public, determine what visitor facilities and opening hours are possible, and compile interpretative material.

Sabina Strachan

7 LESSONS LEARNED

The process of archaeological discovery, recording, research, analysis and reporting at Sunnybrae Cottage has been a long one, culminating in this publication and the ability for Historic Scotland to develop proposals to present the cottage to the public. The authors and staff from Historic Scotland have worked together to produce this 'Lessons Learned' chapter to help us evaluate the project, and also to help other practitioners who are working on, or about to embark on, similar projects.

- Sunnybrae Cottage is the first vernacular building to come into the care of Historic Scotland on behalf of Scottish Ministers since 1965, when the complex of buildings at Arnol, Lewis was procured by the state. Since that time there has been great strides in our appreciation of just how complex a recording project these vernacular buildings present. The challenge of investigating and recording all the phases of the property that were established during this investigation was considerable. It is never possible to fully anticipate the level of recording required and therefore the time necessary to complete this, analyse the data, and to then devise and implement a presentation scheme for a property of this nature. Historic Scotland was fortunate in having access to in-house expertise on the subject of vernacular buildings. Historic Scotland and Headland have now built up considerable experience through the Sunnybrae Cottage project and are now able to advise other practitioners on appropriate levels of recording, timescales and resources required to extract, collate, and publish the necessary data.
- The recording and research has been undertaken by a considerable number of individuals with a range of expertises. A multi-disciplinary approach was thought to be both desirable and necessary for a building of this type, utilising technical skills of Historic Scotland staff in recording and analysis, but also using archaeological contractors to extract detailed information from strategically-placed trenches, including at roof level. A considerable number of people were also involved in the post-excavation, documentary, and oral history research. Occasionally, during survey, this could lead to some duplication but enabled greater scrutiny of the evidence. The critical issue was the coordination of the input of experts, sharing of information, ensuring concordance of data, and communication, both written and oral. These are aspects which require good, consistent management throughout projects of this type.
- The process employed during the archaeological fieldwork involved continual review of Historic Scotland's strategy before approving subsequent phases of investigation. A range of personnel were involved in the decision-making process, undertaking structural investigations, and conservation work as conditions allowed, supported by the archaeologists on-site. This required a staged approach which inevitably had implications for the overall costs and timescales. The lessons learned from the project would enable improved estimates at the outset of a similar project in terms of time and resources. As with any project of this nature a higher level of contingency allowances should always be made.
- The provision of a scaffold shelter over the entire building enabled the friable layers of thatch and turf to be protected as they were excavated and facilitated close-up public access to this level during the work. The shelter allowed the wallheads to be consolidated under cover and the use of lime mortar and limewashes had the benefit of all-weather protection. The provision of the shelter was extremely beneficial to the building allowing the roof to be fully investigated, recorded and repaired. Where possible we would recommend the provision of such a shelter of sufficient size to allow full access for recording and conservation work to all areas. However, this can be expensive.
- This project has undoubtedly benefited from local interest, not least the mechanism by which the potential sale of the cottage was brought to Historic Scotland's attention. Historic Scotland has proactively involved, and updated the local community on, the project, and coordinated educational outreach events for all ages and as part of established programmes such as Doors Open Day. Whilst the results of the oral history research were not as enlightening on the 20th-century phase of Sunnybrae Cottage as we had hoped, it was a worthwhile exercise and is to be recommended for research into buildings which were used or lived-in in living memory.

- The scope of the publication has been focused to concentrate on our findings at Sunnybrae as a case study, a dissemination of the archaeological investigations, and how that could inform other practitioners. By making reference to other Technical Advice Notes a resource is provided to which readers can cross-refer, therefore sections on materials and techniques were selectively used in this publication. Summaries describing the investigative techniques for practitioners using vignettes were considered to be worthwhile. It is important that the scope of any such publication is agreed from the outset. A clear written brief should be drawn up to avoid misunderstanding or abortive works.
- As with any archaeological investigation there has been a focus on finding out more about the early history of the structure to try and answer fundamental questions such as, when was it built and what did it

look like? It was hoped that the excavations within the solum and around the exterior walls would reveal dating material, but this was not to be. The same is true of the dendrochronological analysis of the ash cuppills, however, as a sequence of ash tree-ring dates is built up, the samples may provide useful data in the future. However, every phase of the cottage's existence has been recorded. We would recommend that all phases of a building's history needs to be understood before the most significant parts can be teased out.

Overall, the project was immensely worthwhile and enlightening. The resultant data is extremely useful in helping Historic Scotland devise its presentation proposals for the cottage, informing the public and practitioners about this important building, and developing best practise in understanding Scotland's vernacular buildings.

Sabina Strachan

REFERENCES

- Anon 1893 Frederick Braby and Co. Ltd Catalogue Number 12 (August), 62.
- Anon 1789 *A Tour of Scotland 1789*. National Library of Scotland, MS1080.
- Brannan, L & Frew, C 2002 'Sunnybrae Cottage, Pitlochry, Mortar Analysis Reports', job number: AP810, sample numbers: S1 & S2, unpublished report by the Scottish Lime Centre Trust for Historic Scotland.
- Brewster E: 1830: *The Edinburgh Encyclopedia*. Edinburgh: WM Blackwood.
- Carter, S 2001 'Sunnybrae Cottage, Pitlochry. Thin section analysis of samples of turf and thatch from the roof apex' unpublished report by Headland Archaeology Ltd for Historic Scotland.
- Chambers, R 1830 *The Picture of Scotland*, Edinburgh: William Tait.
- Clapperton, K 2006 'Report on a Watching Brief on ground reduction between the W room and Kitchen extension at Sunnybrae Cottage, Pitlochry' unpublished report by Headland Archaeology Ltd for Historic Scotland.
- Craigie, W A, Aitken A J *et al.* (eds.) 1931-2002 *Dictionary of the Older Scottish Tongue (DOST, 12 Vols.)*.
- Crone, A 2001 'Analysis of the Roof Timbers from Sunnybrae Cottage', unpublished report by AOC Archaeology Group for Historic Scotland.
- Dinnie R 1885 *An Account of the Parish or Birse, Aberdeen. Aberdeen.*
- Douglas, G and Oglethorpe, M 1993 *Brick, Tile and Fireclay Industries in Scotland*. Edinburgh: RCHMS.
- Dunbar 1966 J G *The Historic Architecture of Scotland*. London: Batsford.
- Geddes, G & Holden, T 2005 'Sunnybrae Cottage, Pitlochry: Oral History Transcriptions' unpublished report by Headland Archaeology Ltd for Historic Scotland.
- Geikie W 1885 *Etchings Illustrative of Scottish Character and Scenery*. Edinburgh: William Patterson.
- Geikie, W 1825 *A collection of sketches made during a tour of the Highlands of Scotland*. National Galleries of Scotland Drawings Collection, MS3.
- Grant W and Murrison, D (eds.) 1929-1976 *Scottish National Dictionary (SND, 10 Vols.)*. Edinburgh: Edinburgh University Press.
- Headland Archaeology Ltd 2003 'Sunnybrae Cottage – finds assessment and catalogue' unpublished report for Historic Scotland.
- Holden, T & Baker, L 2000 'Sunnybrae Cottage, Pitlochry. Ph 2 Archaeology' unpublished report by Headland Archaeology Ltd for Historic Scotland.
- Holden, T & Baker, L 2001 'Sunnybrae Cottage, Pitlochry. Ph 2 Archaeology: Pt II' unpublished report by Headland Archaeology Ltd for Historic Scotland.
- Holden, T & Engl, Margaret 'Sunnybrae Cottage, Pitlochry: Detailed recording of the thatch, the gables and the roof' unpublished report by Headland Archaeology Ltd for Historic Scotland.
- Holden, T & Engl, Margaret 2000 'Sunnybrae Cottage, Pitlochry: Data Sources' unpublished report by Headland Archaeology Ltd for Historic Scotland.
- Holden, T & Walker, B 2002 'Sunnybrae Cottage, Pitlochry, Ph 2 Archaeology: Pt III' unpublished report by Headland Archaeology Ltd for Historic Scotland.
- Holden, T & Walker, B 2002 'Sunnybrae Cottage: Preliminary work on site monograph' unpublished report by Headland Archaeology Ltd for Historic Scotland.
- Holden, T 2001 'Sunnybrae Cottage, Pitlochry: The botanical element of the turves from the roof' unpublished report by Headland Archaeology Ltd for Historic Scotland.
- Holden, T G 1998 *The Archaeology of Scottish Thatch*. Edinburgh: Historic Scotland Technical Advice Note 13.
- Hoskins, N & Frew, C 2002 'Sunnybrae Cottage Advisory Report' unpublished report by the Scottish Lime Centre Trust for Historic Scotland.
- Hutcheson A 1927 *Old Stories in Stones and other papers*. Dundee: Wm Kidd.
- Keay, J & Keay, J (eds) 1994 *Collins Encyclopaedia of Scotland*. London: Harper Collins London.

- Kirkdale Archaeology 1999 'Historic Scotland's Properties-in-Care – Minor Archaeological Works 1999. Sunnybrae Cottage, Pitlochry' unpublished watching brief report for Historic Scotland.
- Leneman L 1986 *Living in Atholl: A Social History of the Estates 1685-1785*. Edinburgh: Edinburgh University Press.
- Letts, J 1999 *Smoke Blackened Thatch*. London: English Heritage.
- Lucas A T 1956 'Wattle and Straw Mat Doors in Ireland' *Studia Ethnographica Upsaliensia* XI 16 – 35.
- McDermott, A 2006 'Sunnybrae Cottage. Off site examination of wallpaper fragments' unpublished report for Historic Scotland.
- Mclagan P 1846 Faskally Estate Map in the Butter Archive.
- Megaw B R S 1968 personal communication on wattle doors on his unpublished study of creel houses.
- Pearce, M 2003 'Sunnybrae Cottage, Pitlochry. HSCC Investigation of external lime wash colour', unpublished report by Historic Scotland Conservation Centre.
- Sandman S 1892 *The Memoirs of Mrs S Sandeman (2nd Edition)*. London: James Nisbet.
- Saville, D 2002 'Report on the Cruck Roof Frame at Sunnybrae Cottage, Pitlochry' unpublished report by Carpenter Oak & Woodland Co. Ltd. for Historic Scotland.
- Stewart, A 1791 'The Parish of Moulin', *The Statistical Account of Scotland 1791-1799*, 50-74.
- Walker, B 1979a 'The vernacular Buildings of North-East Scotland: An exploration'. *Scottish Geographical Magazine* 95 April, 45-60.
- Walker, B 1979b *Scottish Vernacular Architecture in Nineteenth Century Photographs*. Dundee: Duncan of Jordanstone College of Art.
- Walker, B 1979c 'Report on Cruck Framed Cottage, Drumdewan, Perthshire', *Vernacular Building* 5, 12-22.
- Walker, B 1985 Farm Buildings and Archaeology: 'The Evidence of Appraising Tickets' *Scottish Archaeological Gazette*, 3 Summer, 8-12.
- Walker, B 1986 'The Hanging Chimney in Scottish Meat Preservation'. *Vernacular Building*, 9, 40-56.
- Walker, B 1988a: 'Lofted Open-Hall Farmhouses in Scotland', *Vernacular Building* 12, 45-49.
- Walker, B 1988b 'Lofted Farmhouses' *Scottish Home and Country*, September, 559-569.
- Walker, Bruce: 1992: 'Claywall' *Materials and Traditions in Scottish Building*, SVBWG: Regional and Thematic Studies No2. Edinburgh. 48-51.
- Walker, Bruce: 2001 'Building Materials and Techniques' in Michael LYNCH (editor) *The Oxford Companion to Scottish History*. University Press, Oxford and New York. 47-50.
- Walker, B 2003 'Notes on the ownership, tenancy and occupancy' unpublished report by Headland Archaeology Ltd for Historic Scotland.
- Walker, B 2003 'Preliminary Notes on the Geikie Sketchbook 1825: A Genre Painter's record of a tour in the Highlands and its relevance to the study of Scottish vernacular building' unpublished report by Headland Archaeology Ltd for Historic Scotland.
- Walker, Bruce: 2004 'The Parallelogram Plan: Accident or Design?' *Yorkshire Buildings 2004* Yorkshire vernacular Buildings Study Group. YORK 52-58.
- Walker, B 2006 *Scottish Turf Construction*. Edinburgh: Historic Scotland Technical Advice Note 30.
- Walker, Bruce 2008a 'The Celtic Cuppill and its implications in building construction and design' *Transactions of the Ancient Monuments Society* 52. 71-106.
- Walker, Bruce 2008b 'Hanging chimneys, smoke chimneys or smoking chimneys in Scottish domestic buildings' *Vernacular Architecture* 39. 78-85.
- Walker B & McGregor, C 1996b *Earth Structures and Construction in Scotland: A guide to recognition and conservation of earth technology in Scottish buildings*. Edinburgh: Historic Scotland Technical Advice Note 6.
- Walker, B & McGregor, C 1998 'Vernacular Buildings' in Omand, D (ed.). *The Perthshire Book*. Edinburgh: Birlinn, 177-184.
- Walker, B, McGregor, C & Stark, G 1996a *Thatches and Thatching Techniques: A guide to conserving Scottish Thatching Traditions*. Edinburgh: Historic Scotland Technical Advice Note 4.

ARCHIVE SOURCES:

A K BELL LIBRARY, PERTH
 ATHOLL ESTATES ARCHIVE
 MANSFIELD ESTATES ARCHIVE
 NATIONAL GALLERIES OF SCOTLAND
 NATIONAL LIBRARY OF SCOTLAND
 SCOTTISH RECORD OFFICE
 THE STIRLING SMITH MUSEUM, STIRLING

GLOSSARY

Battered – Inclined towards the wallhead.

Beam filling – Turf or clay between rafters of ceiling joints at their support used to stiffen the timbers and close the eaves on an open wallhead.

Clod – A lump of earth or, more correctly, an irregular lump of turf.

Composition brick – Bricks made from a mixture of coal shale and clays. The most widely used bricks used in Scotland from 1880s-1980s.

Cuppills – A pair of principal rafters or siles ‘knitted’ together to form a truss, usually rising from the ground or foundation level in the form of an A-frame. From the 1960s to 1990s the Scottish examples were often referred to as crucks but crucks tend to form part of a braced or framed timber structure and cuppills are loosely connected by a roof tree and pans (purlings).

Culm – The stem of a cereal, sedge.

Crook and links – Originally a hook and chain used to support a pot over the fire. Later used for all types of hanging pot support.

Dooks, Douk – A wooden peg driven into a wall to provide a fixing for a nail. Used to provide fixings for strapping etc.

Canopy chimney – A wide chimney where the greater part of the flue projects beyond the face of the wall built behind the hearth. A chimney suspended from the roof structure or supported on posts or brackets over an open hearth.

Dendrochronology – The dating of timbers using the distinctive patterns of tree growth as revealed in the annual rings.

Divet (Diffat, Devit, Divot) – A thin flat turf generally of an oblong form: used for covering cottages, and also for fuel.

Fale, Fail, Feal – A thick grassy turf block often cut to a parallelogram form.

Flaa (Flass) – A thin turf or more correctly a form of water propagated vegetable mat comprising sphagnum moss interlaced with the root systems of plants that have propagated on its surface until it forms a thick homogeneous mat.

Ground – Rough timber framing generally let in to the surface of walls.

Grip – see tippet

Hallan, halland hallan wa – A door screen erected between the door and the fireplace usually finished with daub.

Hanging Chimney (Lum, lumb) – A chimney, kitted out internally for the smoking of meats, fish, poultry or cheese.

Mortar – A paste of clay and water, composed of moistened clay and sand with chopped straw etc used in making air-dried bricks, plastering etc sub-soil of clay and sand with a mixture of vegetable matter.

Moss – A morass or bog. An alternative name for peat.

Peat – Compressed vegetable matter partly decomposed in water and partly carbonised, used for fuel.

Pan – A purlin.

Rantle tree – A timber that supports the cooking equipment over the hearth.

Runwa’ – An inner cross-wall.

Scraw – A thin turf or sod, generally used for roofing.

Skew – Verge.

Slapping – An opening formed in a wall.

Sile – A rafter but more specifically the principal timbers of a cuppill.

Sod – A species of earthen fuel, used for the back of a fire on an open hearth. In Ireland, a building material comprising blocks of green turf.

Stake and rice – Wattle work.

Stob thatching – A style of thatching that relies on a combination of weight and friction to hold the thatch in place. Small bottles or twists of straw are thrust into an existing thatch or into the sub-strata using a stob.

Stob – This is a specially made thrusting rod with a small forked end a long slender shaft and a comfortable handle. The shaft must be long enough to allow the new straw to be inserted to its full length without damage to the existing roof.

Sward – An expanse of ground covered with short grass, lawn-like ground, turf.

Timber cladding – External timber boarding.

Tippet – A twisted handful of straw that is used in certain types of thatching or thatching repairs.

Wattle – Poles intertwined with twigs, reeds or branches used in the construction of walls, hurdles and fences.

Wattle and daub – Clay mortared wattle making a thin wall.

APPENDIX I: A SUMMARY OF FINDS FROM SUNNYBRAE COTTAGE

SUNNYBRAE COTTAGE, PITLOCHRY – FINDS AND SAMPLES TAKEN BY HISTORIC SCOTLAND		
FIND	LOCATION FOUND	LOCATION STORED
GARDEN		
Garden tools	various implements recovered from 3 sheds	Historic Scotland, Kerse Road depot
HOUSE		
Fragment of <i>The Scotsman</i> newspaper (1861)	North of West Hearth	Historic Scotland, Croft-an-Righ
Fragment of newspaper recording the launch of Agamemnon (1852)	NE Cuppill	Historic Scotland, Croft-an-Righ
Bottle cork	at left rear NE cruck post on lining removal	Historic Scotland, Croft-an-Righ
Craven 'A' cigarette packet	found below sill board of Boxroom window	Historic Scotland, Croft-an-Righ
Fibreboard	wall lining over framework of Boxroom/Bedroom partition	Historic Scotland, Croft-an-Righ
Glass	under mortar debris on sill of East gable window in roofspace	Historic Scotland, Croft-an-Righ
Linen sample	below Living Room fireplace hearth between concrete and solum	Historic Scotland, Croft-an-Righ
Mortar samples	taken from Living Room fireplace	Historic Scotland, Croft-an-Righ
Page from Chambers Journal	on ceiling boards in SE corner of roofspace	Historic Scotland, Croft-an-Righ
Part timber window frame	lying in East gable window opening in roofspace	Historic Scotland, Croft-an-Righ
Soot and Plaster samples	taken from original wall face behind Living Room fireplace	Historic Scotland, Croft-an-Righ
Timber	from hearth at west end of west gable	Headland Archaeology
Timber panel	on ceiling boards in roofspace below East Gable window	Historic Scotland, Croft-an-Righ
Underwear	eaves in roofspace over Bedroom	Historic Scotland, Croft-an-Righ
Vinyl flooring	5 samples taken from Boxroom and Bedroom floors	Historic Scotland, Croft-an-Righ
Wallpaper	from partition wall of eastern room	Headland Archaeology
Wallpaper	layers of samples removed from all three rooms	Historic Scotland, Croft-an-Righ
ROOF		
Straw thatch		Headland Archaeology
Stick-like thatch		Headland Archaeology
Straw thatch		Headland Archaeology
Straw		Headland Archaeology
Turf		Headland Archaeology
Bracken		Headland Archaeology
Thatch		Headland Archaeology
Bagged package (mortar)		Headland Archaeology
Straw		Headland Archaeology
Mortar		Headland Archaeology
Straw		Headland Archaeology
Mixed finds		Headland Archaeology

